



SERVING THE FOOD INDUSTRY SINCE 1951

Reach-in Refrigerator

ITEM:	50024	50110	50026	50028
MODEL:	RE-CN-0021-HC	RE-CN-0035-HC	RE-CN-0041-HC	RE-CN-0067-HC



Perfect solution for keeping your food and ingredients fresh and ready to use.

Top-quality commercial Reach-in Refrigerators are designed to deliver high performance, energy efficiency, and long-lasting reliability. Ideal for restaurants, cafés, and food service operations, this unit offers ample storage and consistent cooling to keep large quantities of ingredients fresh and easily accessible. With a spacious interior, it's dependable solution for all your cold or frozen storage needs.

- 430 Stainless Steel exterior
- 304 Stainless Steel interior
- Digital temperature control with LCD display
- Self-closing doors
- Automatic defrost
- Interior lighting
- Adjustable PVC-coated shelves
- Heavy-duty casters with brakes

Telephone: 1-800-465-0234

Fax: (905) 607-0234

Email: sales@omcan.com

Website: www.omcan.com



Authorized Dealer

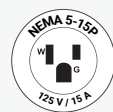

*50024, 50028

Made in China

Updated: Sep 15, 2025

js Page 1 / 4

TECHNICAL SPECIFICATION				
Features	29"- 1 Door	40"- 2 Door	54"- 2 Door	81"- 3 Door
Item	50024	50110	50026	50028
Model	RE-CN-0021-HC	RE-CN-0035-HC	RE-CN-0041-HC	RE-CN-0067-HC
Capacity	650 L / 23 cu.ft	749.3 L / 26.46 cu.ft.	1321 L / 46.65 cu.ft.	2040 L / 72.04 cu.ft.
Horse Power	0.2 HP	0.5 HP	0.25+ HP	0.75 HP
Current	2.6A	4.1A	3.8A	9A
Refrigerant	R290			
Electrical	110V / 60Hz / 1Ph			
Temperature Range	0.5 - 5°C / 33 - 41°F			
Isolation Material	Cyclopentane			
Cooling System	Ventilated			
Number of Doors	1 Door	2 Door	2 Door	3 Door
Shelf Capacity	59.5 lbs / 27 kgs	88 lbs / 39.9 kgs	59.5 lbs / 27 kgs	59.5 lbs / 27 kgs
Number of Shelves	3	6	6	9
Net Weight	282 lbs / 128 kgs	308 lbs / 139.7 kgs	447.5 lbs / 203 kgs	617.3 lbs / 280 kgs
Gross Weight	337 lbs / 153 kgs	374 lbs / 169.6 kgs	513.7 lbs / 233 kgs	705.5 lbs / 320 kgs
Net Dimensions (WDH)	29" x 32.3" x 82.5" / 736 x 818 x 2095 mm	39.5" x 29.5" x 82.5" / 1004 x 750 x 2095 mm	54" x 32.2" x 82.5" / 1371 x 818 x 2095 mm	80.9" x 32.2" x 82.5" / 2054 x 818 x 2095 mm
Interior Dimensions (WDH)	27.1" x 24.4" x 53.5" / 688 x 620 x 1360 mm	35" x 24.4" x 51.6" / 888 x 620 x 1310 mm	49.4" x 27.1" x 60.2" / 1255 x 688 x 1530 mm	76.3" x 27.1" x 60.2" / 1938 x 688 x 1530 mm
Gross Dimensions (WDH)	31" x 34" x 85" / 787 x 864 x 2159 mm	42.2" x 31.9" x 82.5" / 1070 x 810 x 2095 mm	56.7" x 35" x 83.5" / 1440 x 890 x 2120 mm	83.5" x 35" x 83.5" / 2120 x 890 x 2120 mm
Plug Type	NEMA 5-15P			

TECHNICAL DRAWING

Item: 50024/ 29"

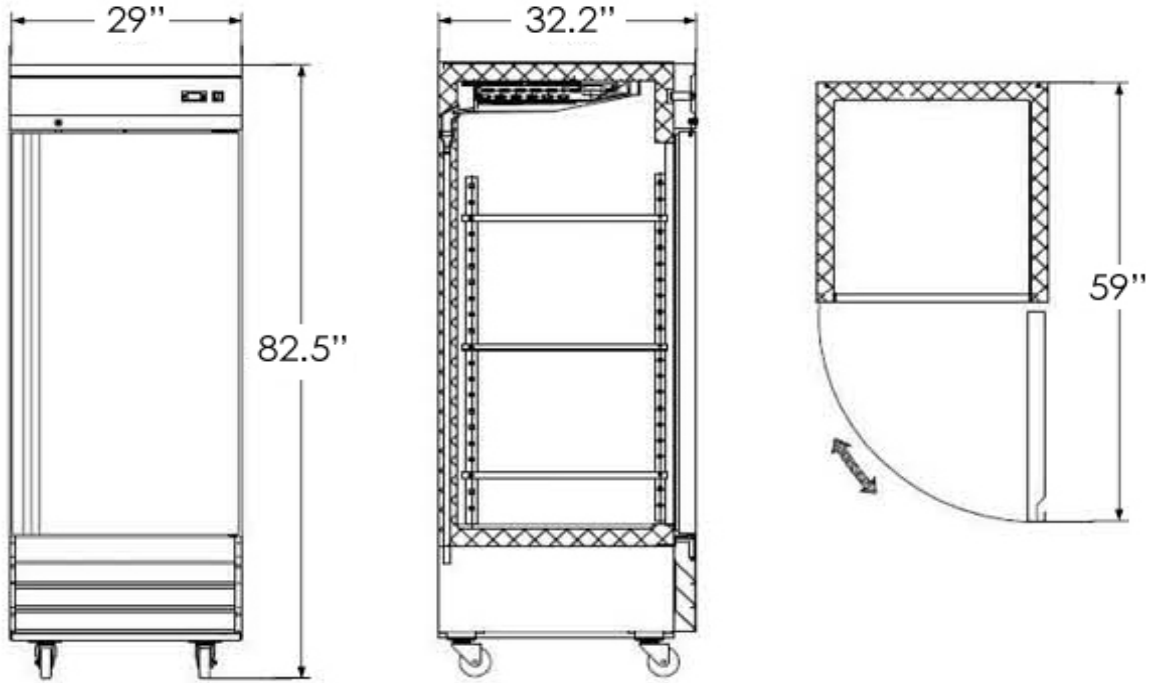

Item: 50110/ 40"

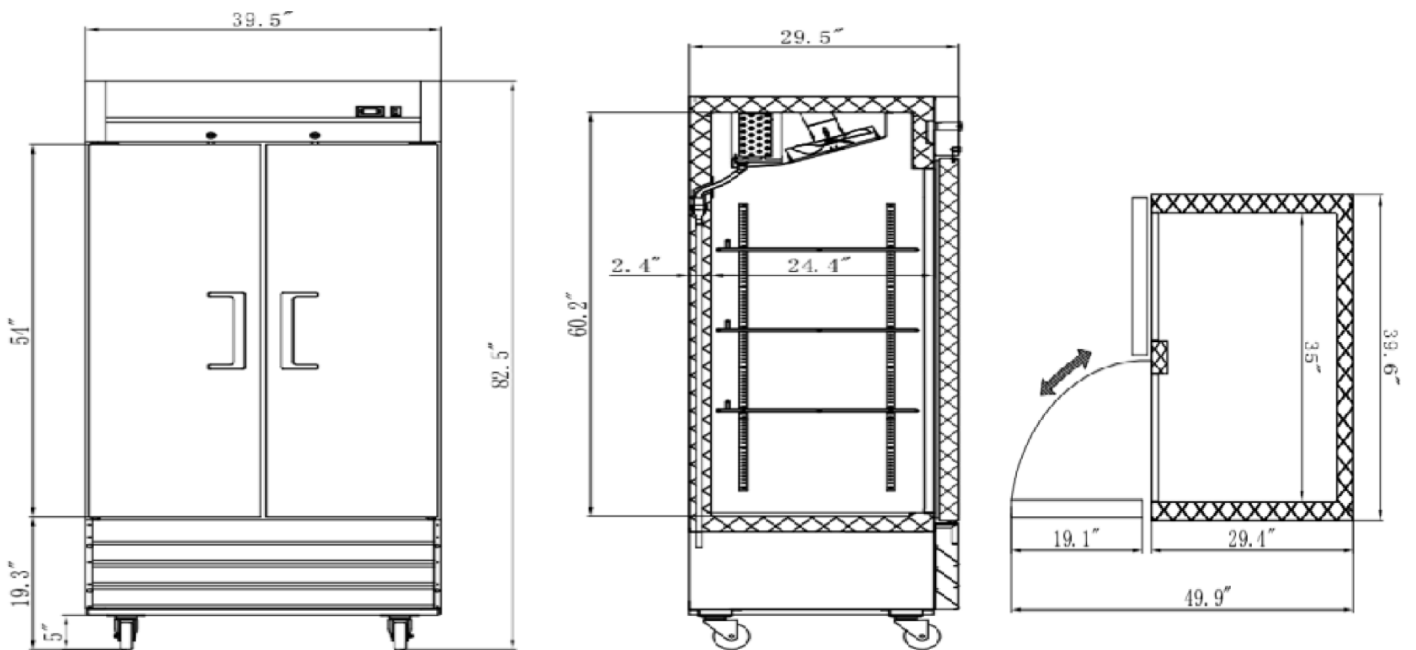

TECHNICAL DRAWING

Item: 50026 / 54"

54" / 1371 mm

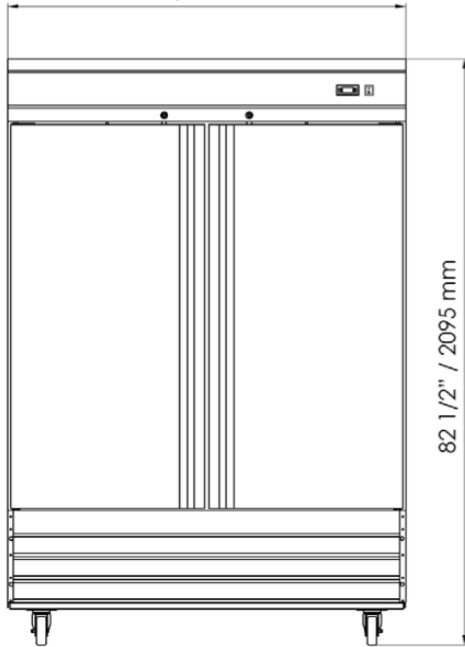

82 1/2" / 2095 mm

32 1/4" / 818 mm

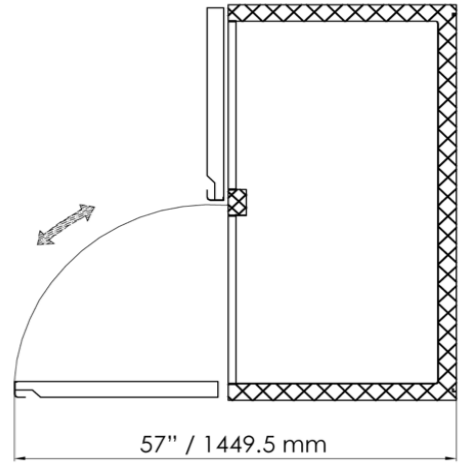
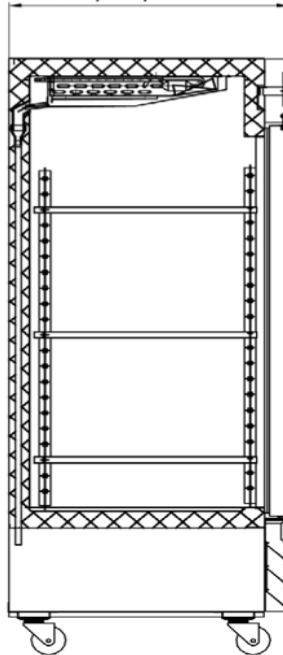

57" / 1449.5 mm

Item: 50028 / 81"

81"

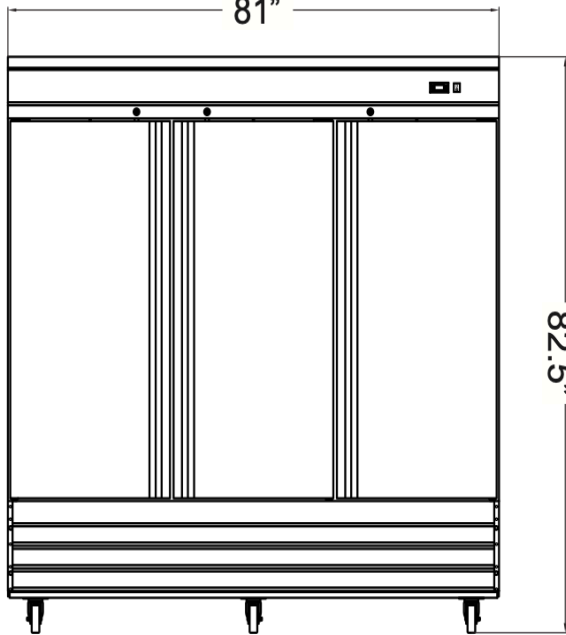

82.5"

32"

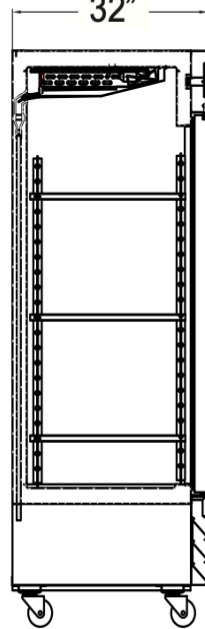

57"

