



SERVING THE FOOD INDUSTRY SINCE 1951

Countertop Electric Hot Plates 2 Burners - 4,000W - 208V/60Hz/1ph

ITEM: 48556
MODEL: CE-CN-EHP15 208



Quick and Efficient Solution for Fast, Even Heating

Electric hot plate are a perfect addition to any food service operation. 2 kW round plate elements with easy-to-clean flat surface.

Provides a solid flat surface for fast, even heating. Round plates are 9" (229 mm) diameter for maximum pan contact.

Infinite heat controls for maximum cooking flexibility.

FEATURES:

- Heavy Duty Metal Knobs
- Incrementless Heat Adjustment
- Adjustable Stainless Steel Feet

Telephone: 1-800-465-0234

Fax: (905) 607-0234

Email: sales@omcan.com

Website: www.omcan.com



Authorized Dealer



Made in China

(Version 2026.04)

Page 1 / 2

TECHNICAL DRAWING

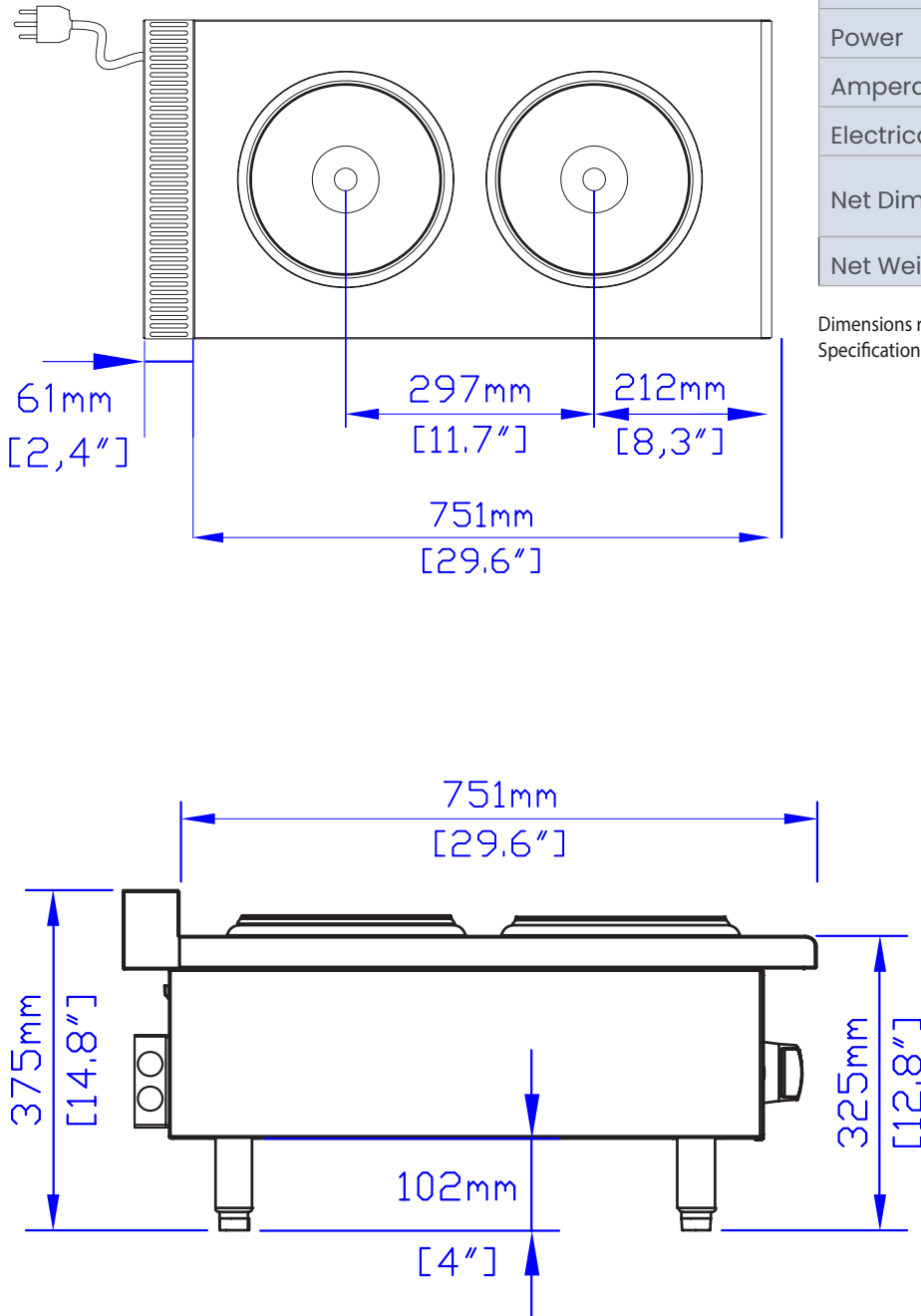

TECHNICAL SPECIFICATION

Item	48556
Model	CE-CN-EHP15 208
Power	4,000 W
Amperage	16.7 A
Electricals	208V / 60 Hz / 1ph
Net Dimensions	15" x 29.6" x 14.8" (381 x 751 x 375 mm)
Net Weight	46.3 lb (21 kg)

Dimensions rounded up to the nearest tenth inch or millimeter.
Specifications subject to change without notice.

