



**Beer Keg Cooler**  
*Model BC-CN-0152*  
*Item 46500*  
**Instruction Manual**



*Revised - 08/05/2022*



Toll Free: 1-800-465-0234  
Fax: 905-607-0234  
Email: [service@omcan.com](mailto:service@omcan.com)  
[www.omcan.com](http://www.omcan.com)

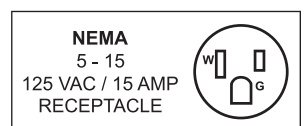

# ***Table of Contents***

Model BC-CN-0152

---

<b>Section</b>	<b>Page</b>
Disclaimer -----	3
General Information -----	4 - 5
Safety and Warranty -----	5 - 8
Technical Specifications -----	8
Installation -----	9 - 12
Operation -----	12 - 14
Maintenance -----	15
Parts Breakdown -----	16 - 18
Electrical Schematics -----	19
Notes -----	20 - 22
Warranty Registration -----	23

## *Disclaimer*

---

***OMCAN IS NOT RESPONSIBLE FOR ANY DAMAGES DUE TO WATER LEAKS. WARRANTY FOR WATER LEAKS IS VOID IF THE WICKING PAD IS NOT REPLACED EVERY SIX MONTHS, AND IF THE AMBIENT ROOM TEMPERATURE EXCEEDS 75°F AND 55% RELATIVE HUMIDITY, AND THE APPLIANCE DRAIN IS NOT CONNECTED DIRECTLY TO THE FLOOR DRAIN.***

# General Information

---

Omcan Manufacturing and Distributing Company Inc., Food Machinery of America, Inc. dba Omcan and Omcan Inc. are not responsible for any harm or injury caused due to any person's improper or negligent use of this equipment. The product shall only be operated by someone over the age of 18, of sound mind, and not under the influence of any drugs or alcohol, who has been trained in the correct operation of this machine, and is wearing authorized, proper safety clothing. Any modification to the machine voids any warranty, and may cause harm to individuals using the machine or in the vicinity of the machine while in operation.

## CHECK PACKAGE UPON ARRIVAL

Upon receipt of an Omcan shipment please inspect for external damage. If no damage is evident on the external packaging, open carton to ensure all ordered items are within the box, and there is no concealed damage to the machine. If the package has suffered rough handling, bumps or damage (visible or concealed), please note it on the bill of lading before accepting the delivery and contact Omcan within 24 hours, so we may initiate a claim with the carrier. A detailed report on the extent of the damage caused to the machine must be filled out within three days, from the delivery date shown in the shipping documents. Omcan has no recourse for damaged products that were shipped collect or third party.

**Before operating any equipment, always read and familiarize yourself with all operation and safety instructions.**

Omcan would like to thank you for purchasing this machine. It's of the utmost importance to save these instructions for future reference. Also save the original box and packaging for shipping the equipment if servicing or returning of the machine is required.

---

Omcan Fabrication et distribution Compañie Limité et Food Machinery d'Amérique, dba Omcan et Omcan Inc. ne sont pas responsables de tout dommage ou blessure causé du fait que toute personne ait utilisé cet équipement de façon irrégulière. Le produit ne doit être exploité que par quelqu'un de plus de 18 ans, saine d'esprit, et pas sous l'influence d'une drogue ou d'alcool, qui a été formé pour utiliser cette machine correctement, et est vêtu de vêtements de sécurité approprié. Toute modification de la machine annule toute garantie, et peut causer un préjudice à des personnes utilisant la machine ou des personnes à proximité de la machine pendant son fonctionnement.

## VÉRIFIEZ LE COLIS DÈS RÉCEPTION

Dès réception d'une expédition d'Omcan veuillez inspecter pour dommages externes. Si aucun dommage n'est visible sur l'emballage externe, ouvrez le carton afin de s'assurer que tous les éléments commandés sont dans la boîte, et il n'y a aucun dommage dissimulé à la machine. Si le colis n'a subi aucune mauvaises manipulations, de bosses ou de dommages (visible ou cachée), notez-le sur le bond de livraison avant d'accepter la livraison et contactez Omcan dans les 24 heures qui suivent, pour que nous puissions engager une réclamation auprès du transporteur. Un rapport détaillé sur l'étendue des dommages causés à la machine doit être rempli dans un délai de trois jours, à compter de la date de livraison indiquée dans les documents d'expédition. Omcan n'a aucun droit de recours pour les produits endommagés qui ont été expédiés ou cueilli par un tiers transporteur.



# General Information

---

Avant d'utiliser n'importe quel équipement, toujours lire et vous familiariser avec toutes les opérations et les consignes de sécurité.

Omcan voudrais vous remercier d'avoir choisi cette machine. Il est primordial de conserver ces instructions pour une référence ultérieure. Également conservez la boîte originale et l'emballage pour l'expédition de l'équipement si l'entretien ou le retour de la machine est nécessaire.

---

Omcan Empresa De Fabricacion Y Distribucion Inc. Y Maquinaria De Alimentos De America, Inc. dba Omcan y Omcan Inc. no son responsables de ningun daño o perjuicio causado por cualquier persona inadecuada o el uso descuidado de este equipo. El producto solo podra ser operado por una persona mayor de 18 años, en su sano juicio y no bajo alguna influencia de droga o alcohol, y que este ha sido entrenado en el correcto funcionamiento de esta máquina, y ésta usando ropa apropiada y autorizada. Cualquier modificación a la máquina anula la garantía y puede causar daños a las personas usando la máquina mientras esta en el funcionamiento.

## REVISE EL PAQUETE A SU LLEGADA

Tras la recepcion de un envio Omcan favor inspeccionar daños externos. Si no hay daños evidentes en el empaque exterior, Habra el carton para asegurarse que todos los articulos solicitados estén dentro de la caja y no encuentre daños ocultos en la máquina. Si el paquete ha sufrido un manejo de poco cuidado, golpes o daños (visible o oculto) por favor anote en la factura antes de aceptar la entrega y contacte Omcan dentro de las 24 horas, de modo que podamos iniciar una reclamación con la compañía. Un informe detallado sobre los daños causados a la máquina debe ser llenado en el plazo de tres días, desde la fecha de entrega que se muestra en los documentos de envío. Omcan no tiene ningun recurso por productos dañados que se enviaron a recoger por terceros.

Antes de utilizar cualquier equipo, siempre lea y familiarizarse con todas las instrucciones de funcionamiento y seguridad.

Omcan le gustaría darle las gracias por la compra de esta máquina. Es de la mayor importancia para salvar estas instrucciones para futuras consultas. Además, guarda la caja original y el embalaje para el envío del equipo si servicio técnico o devolución de la máquina que se requiere.

# Safety and Warranty

---

## BEFORE USING YOUR BEER DISPENSER

Remove the exterior and interior packing. Check to be sure you have all of the following parts:

- 1 Safety Guard Rail.
- 1 Drip Tray (2 Pieces).
- 1 CO2 Cylinder Support.
- 1 CO2 Regulator (Box).

# Safety and Warranty

---

- 1 CO2 Empty Cylinder(Box).
- 1 CO2 Air Line Hose (Red).
- 1 Beer Keg Coupler (Box).
- 1 Beer Tower.
- 1 Pull Handle (Beer Tower Faucet).
- 4 Plugs: For Guard Rail Holes.
- 1 Metal Plate For Cabinet Bottom.
- 2 Steel Wire Shelves.
- 1 Steel Clamp for Red Hose.
- 4 Castors (2 Front with Locks).

Before plugging in the keg cooler, let it stand upright for approximately 2 hours. This will reduce the possibility of a malfunction in the cooling system from handling during transportation. Clean the interior surface with lukewarm water using a soft cloth.

## ELECTRICAL CONNECTION

**WARNING: Improper use of the grounded plug can result in the risk of electrical shock. If the power cord is damaged, have it replaced by an authorized service center.**

This Beer Dispenser should be properly grounded for your safety. The power cord of this Beer Dispenser is equipped with a three-prong plug which mates with standard three prong wall outlets to minimize the possibility of electrical shock.

Do not under any circumstances cut or remove the third ground prong from the power cord supplied.

Use of extension cords is not recommended.

This Beer Dispenser requires a standard 115/120-volt, 60Hz electrical outlet with three-prong ground receptacle. The cord should be secured behind the Beer Dispenser and not left exposed or dangling to prevent accidental injury.

Never unplug the Beer Dispenser by pulling the power cord. Always grip the plug firmly and pull straight out from the receptacle.

**WARNING: CO2 GAS CAN BE DANGEROUS! CO2 cylinders contain high-pressure compressed gas which can be hazardous if not handled properly. Make sure you READ and UNDERSTAND the following procedures for CO2 cylinders BEFORE INSTALLATION.**

1. ALWAYS connect the CO2 cylinder to a regulator. Failure to do so could result in explosion with possible injury when the cylinder valve is opened.
2. NEVER connect the CO2 cylinder directly to the product container.
3. ALWAYS follow correct procedures when cylinders are changed.
4. ALWAYS secure the cylinder in an upright position.
5. NEVER drop or throw a CO2 cylinder.



# Safety and Warranty

---

6. ALWAYS keep a CO2 cylinder away from heat. Store extra cylinders in a cool place (preferably 70°F). Securely fasten with a chain in an upright position when storing.
7. ALWAYS ventilate and leave the area immediately if CO2 leakage has occurred.
8. ALWAYS check the D.O.T. test date on the cylinder neck before installation. If over five (5) years, do not use, return cylinder to gas supplier.
9. NEVER connect a product container unless there are two (2) safety's in the pressure system:
  - a. One at or on the CO2 regulator.
  - b. One at or on the product coupler or in the pressure gas line.

## INSTALLATION OF BEER DISPENSER

- This appliance is designed to be free standing only, and should not be recessed or built-in.
- Place your Beer Dispenser on a floor that is strong enough to support the Beer Dispenser when it is fully loaded.
- Allow 3 inches of space between the back and sides of the Beer Dispenser, which allows the proper air circulation to cool the compressor.
- Locate the Beer Dispenser away from direct sunlight and sources of heat (stove, heater, radiator, etc.). Direct sunlight may affect the acrylic coating and heat sources may increase electrical consumption. Extreme cold ambient temperatures may also cause the Beer Dispenser not to perform properly. This unit is not designed for outside installation (ie: garages, porches, etc.)
- Avoid locating the Beer Dispenser in excessive humidity.
- Plug the Beer Dispenser into a dedicated, properly installed-grounded wall outlet. Do not under any circumstances cut or remove the third (ground) prong from the power cord. Any questions concerning power and or grounding should be directed toward a certified electrician or an authorized service center.
- After plugging the appliance into a wall outlet, allow the unit to cool down for 2-3 hours before placing any contents in the Beer Dispenser compartment.

**RESIDENTIAL USERS: Vendor assumes no liability for parts or labor coverage for component failure or other damages resulting from installation in non-commercial or residential applications. The right is reserved to deny shipment for residential usage; if this occurs, you will be notified as soon as possible.**

## 1 YEAR PARTS AND LABOUR BENCH WARRANTY

Within the warranty period, contact Omcan Inc. at 1-800-465-0234 to schedule a drop off to either an Omcan authorized service depot in the area, or to an Omcan Service warehouse to repair the equipment.

Unauthorized maintenance will void the warranty. Warranty covers electrical and part failures not improper use.

Please see <https://omcan.com/disclaimer> for complete info.

# Safety and Warranty

---

## WARNING:

The packaging components are classified as normal solid urban waste and can therefore be disposed of without difficulty.

In any case, for suitable recycling, we suggest disposing of the products separately (differentiated waste) according to the current norms.

**DO NOT DISCARD ANY PACKAGING MATERIALS IN THE ENVIRONMENT!**

# Technical Specifications

---

<b>Model</b>	<b>BC-CN-0152</b>
<b>Capacity</b>	152 L / 5.37 cu.ft.
<b>Electrical</b>	115V / 60Hz / 1
<b>Temperature Range</b>	2 - 8°C / 35.6 - 46.4°F
<b>Max Ambient Temp Rating</b>	24°C / 75°F
<b>Foaming Components</b>	C - P
<b>Refrigerant</b>	R600a
<b>Keg Size Supported</b>	20 L / 5 Gal
	30 L / 7.75 Gal
	58.5 L / 15.5 Gal
<b>Weight</b>	79.4 lbs. / 36 kgs.
<b>Packaging Weight</b>	110 lbs. / 50 kgs.
<b>Dimensions</b>	20.7" x 26.2" x 33.2" / 526 x 665 x 843mm
<b>Packaging Dimensions</b>	36" x 24" x 40" / 915 x 610 x 1016mm
<b>Item Number</b>	46500

# Installation

## CASTOR BRAKE INSTALLATION

Install the four castors (2 locking castors at front) into the units bottom (four screw holes pre-supplied) Figure (1) before installation. Figure (2) is the final version.

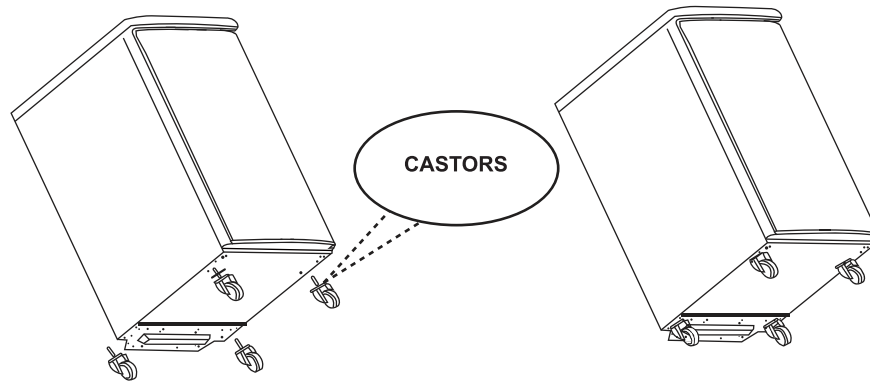

Figure 1

Figure 2

## INSTALLATION OF CO2 CYLINDER SUPPORT

Install the metal support provided onto the 4 studs located on the exterior back wall. Align the holes in the support with the studs and push down firmly. (See Figure 1)

## INSTALLATION OF CO2 CYLINDER

- The CO2 Cylinder does not come filled. The cylinder must be filled with CO2 prior to use.
- Install your fully charged cylinder into the support stand.

## INSTALLATION OF CO2 REGULATOR

Attach the CO2 regulator to the cylinder by turning the regulator nut onto cylinder valve, making sure washer is securely inserted into connecting nut. Tighten snug using an adjustable wrench (not supplied) and assure there are no leaks. (See Figure 2)

## INSTALLATION OF CO2 AIR LINE OUTSIDE CABINET

- Remove plug located at the exterior back (top left hand corner).
- Save it for later use if you decide to convert unit to a refrigerator.
- Insert the open end of the air line (red) line the cabinet through the uncovered hole. (See Figure 4)

## INSTALLATION OF CO2 AIR LINE HOSE TO REGULATOR

- Attach the open end of the red hose to the hose barb connection on the regulator.
- Secure hose by using one clamp provided. Use pliers/screwdriver to tighten clamp to prevent leaks. (See Figure 3)

## INSTALLATION OF THE BEER TOWER

- Remove the top plug by twisting and pulling out, saving it for later use if you decide to convert unit to an all refrigerator unit.
- Unravel the beer line (clear hose) from the tower and insert the beer line and wing nut through the uncovered hole on top.
- Lock the beer tower assembly to the top and make sure to position the beer faucet so it is aligned with

# Installation

---

the cabinet front (6 o'clock position). You accomplish this by aligning the bottom of the beer tower to the 3 grooves on the top cabinet and tighten by hand clockwise to properly lock.

- The plastic gasket, can be used to make the connection between the tower and the cooler tighter if needed. If Beer Tower will not turn to lock in place, try removing the plastic gasket.

## INSTALLATION OF PROTECTIVE METAL PLATE

This plate should always be installed when the keg is in place to protect against unnecessary damage to the floor of the cabinet.

## INSTALLATION OF THE BEER KEG

- Position the beer keg directly in front of the open door. Using keg handles only, carefully lift the beer keg. (See Figure 5)
- To place the beer keg inside the cabinet, brace your knees behind the beer keg. Lift the front of the keg just enough so the front edge of the keg is resting on the front edge of the Beer Dispenser bottom cabinet. (See Figure 6)
- Grasp the keg handles and slide it all the way into the cabinet.

## INSTALLATION OF THE KEG COUPLER

Insert the keg coupler provided into the locking neck of the beer keg and turn it clockwise to lock into position, making sure the keg coupler is in the closed position. (See Figure 7)

## INSTALLATION OF THE CO2 AIR LINE HOSE

Attach the end of the air line (red) hose provided to the hose connection on the keg coupler.

## CONNECTING THE BEER TOWER TO COUPLER

- Make sure the washer is properly inserted into the wing nut.
- Make sure the small round bead is in place (dropped down into the top of the coupler).
- Make sure the ball retainer is in place on the coupler, with the "arms" down into the coupler.
- Place wing nut into the top of the coupler turning until tight.

## HOW TO TAP A KEG OF BEER

- Make sure that the CO2 is turned off, and the Secondary valve on the regulator is in the "Closed" position.
- Pull out and release the pressure release valve on the Coupler to purge any air pressure.
- Make sure the beer tower faucet is in the closed position.
- Pull tapping handle out and press downward until it locks into position. (See Figure 8) The keg is now tapped.

## OPENING THE CO2 CYLINDER MAIN VALVE

- Make sure the secondary shut-off valve (shown in figure 9 in "Open" position) is closed. To open the main CO2 cylinder valve, slowly turn the main valve counter-clockwise until fully open.
- Notice the needle on the regulator gauge start to climb.

## ADJUSTING THE CO2 REGULATOR

The gauge monitors low internal keg pressure and should be adjusted to read between 10-12 psi. (See Figure 10). The pressure can be adjusted as needed.

# Installation

- Release adjustment lock nut marked 2.
- Using a flat screwdriver, turn regulator screw marked 3.
  - To increase pressure, turn screw clockwise.
  - To decrease pressure, turn screw counter-clockwise.
- Retighten lock nut marked 2.
- Open secondary shut off valve to let CO2 flow into the keg.
- Allow several minutes for the keg to properly pressurize. Regulator gauge may drop while this happens.
 

**Note: Listen for hissing along all connections to identify if there are any leaks.**

### SPANNER FAUCET WRENCH (NOT INCLUDED)

Spanner faucet wrench (not provided) is for either removing or tightening the connection.

### PLASTIC FAUCET LEVER

Attach the black plastic lever (pull handle) to the top of the faucet by tightening it by hand clockwise until the end, holding in the silver nut underneath so it does not turn. If there is still a small drip from the faucet, you may have tightened the plastic lever too much and may need to unscrew silver snug counter-clockwise one turn.

### DISPENSING OF BEER

- Keep beer keg refrigerated at all times.
- Never allow beer lines to dry out.
- Use clean beer glassware before pouring.
- Hold glass at a 45° angle when 2/3 full, start to straighten glass as the glass fills.
- Always make sure the faucet handle is pushed all the way back.

**Note: Keg sizes that can be used in your beer dispenser.**

1/2 Barrel	59 Liters	15.5 gals.	1984 oz.	164/12-oz. Glass
1/4 Barrel	30 Liters	7.8 gals.	992 oz.	82/12-oz. Glass
1/6 Barrel	20 Liters	5.2 gals.	661 oz.	55/12-oz. Glass
1/8 Barrel	15 Liters	4.0 gals.	496 oz.	41/12-oz. Glass

**Note: Our Beer dispenser accepts standard kegs up to 16-1/8" in diameter, and up to 23-3/8" in height. Check with your distributor to make sure keg is correct size.**

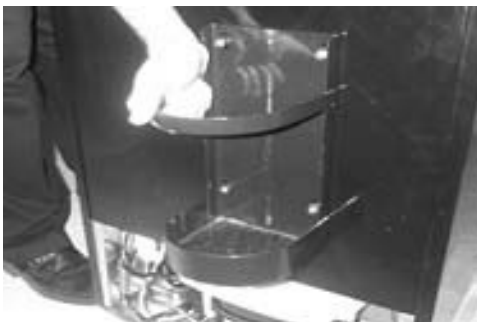

Figure 1



Figure 2



Figure 3

# Installation

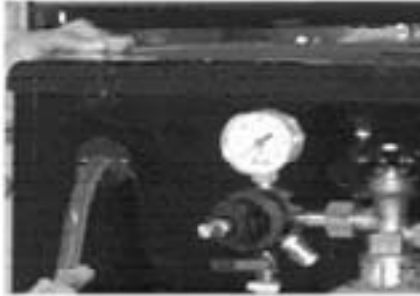

Figure 4



Figure 5



Figure 6

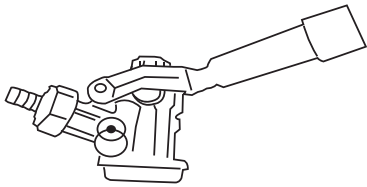

Figure 7

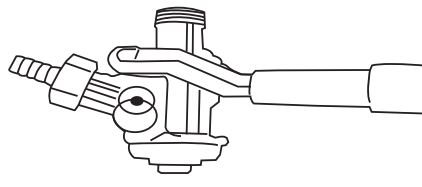

Figure 8

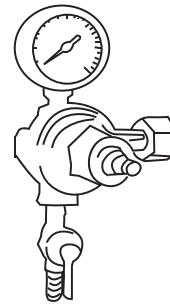

Figure 9

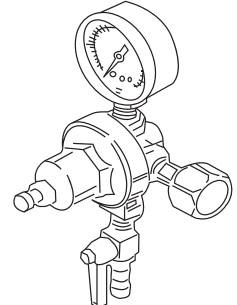

Figure 10

# Operation

## SETTING THE TEMPERATURE

The temperature is controlled by adjusting/setting the thermostat control knob. To start the unit and achieve maximum cooling quickly;

- Turn the temperature control knob clockwise to the furthest (maximum) setting on the blue (wide) section of the control dial. (Fig A)
- Allow the unit to run at this setting for 3-4 hours.
- When maximum cooling is achieved, turn back the temperature control knob to a moderate/medium temperature.
- To turn off (no cooling) rotate the control knob to the “O” (off) position. (Fig.B.)

Fig A.



FigB.

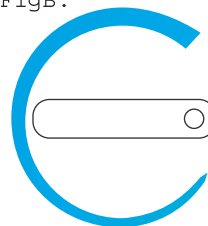

## AUTOMATIC DEFROSTING

There is no need to defrost the Beer Dispenser. Defrost water collects and passes thru the drain outlet in the rear wall into a tray located above the compressor, where it evaporates.

**NOTE: If the unit is unplugged, power lost, or turned off; you must wait 3 to 5 minutes before restarting the unit. If you attempt to restart before this time delay, the Beer Dispenser may not start.**

## CONVERTING TO AN “ALL REFRIGERATOR”

1. Turn off the control knob to the “OFF” position.
2. Close the main valve on the CO2 cylinder.
3. Close the secondary shut-off valve on the regulator pipe.
4. Close the connection between the beer keg and the keg coupler.
5. Drain any remaining beer from the lines.
6. Disconnect the beer line and CO2 air line from the keg coupler.
7. Remove the beer keg.
8. Remove the keg coupler.
9. Disconnect the air line from the CO2 cylinder.
10. Remove the CO2 air line from cabinet plug.
11. Replace the air line rear cabinet plug.
12. Remove the beer tower. Also pull the beer line thru the top of the cabinet.
13. Replace the top cabinet plug.
14. Adjust temperature as desired.

## CHANGING THE REVERSIBLE DOOR

This Beer Dispenser has a door that can be set to open from the left or right side. The unit is delivered to you with the door opening from the left side. To reverse the opening direction, please follow the instructions below.

**Caution: To avoid personal injury to yourself and/or property, we recommend that someone assist you during the door reversal process.**

1. Undo the three screws in each bracket using the Phillips screwdriver.
2. Remove the screws and bracket. Place to one side.
3. Slide the fridge door down about 15cm (6”) and off the top hinge pin and lift away from the freezer.
4. Using the flat bladed screw driver remove the pin from the top bracket. Replace it in the hinge bracket on the opposite side.
5. Remove the screw from the side of the fridge where the bracket is to be re-fitted.
6. Slide the fridge door back on to the top hinge, making sure it’s the right way up. Screw the bottom hinge into place on the new side.
7. Check that the door is aligned horizontally and vertically and that the seals are closed on all sides before finally tightening the bottom hinge. Re-adjust the leveling feet.

# Operation

---

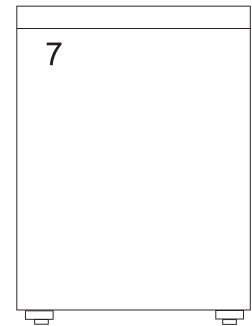
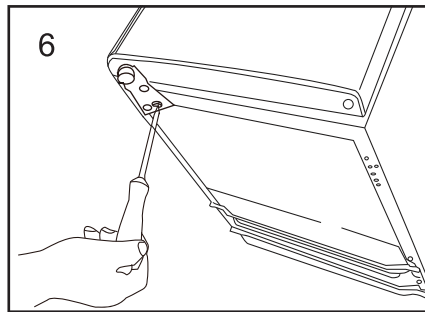
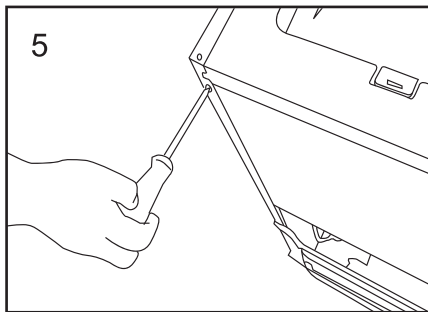
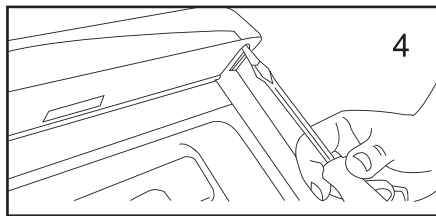
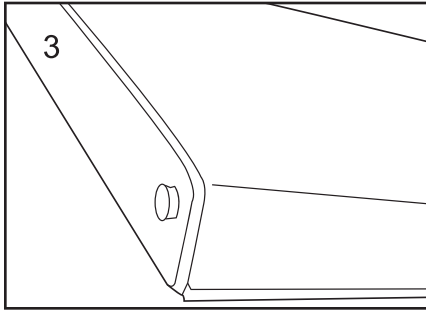
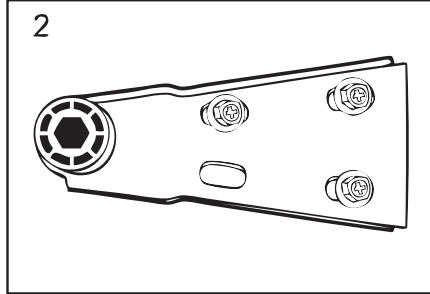
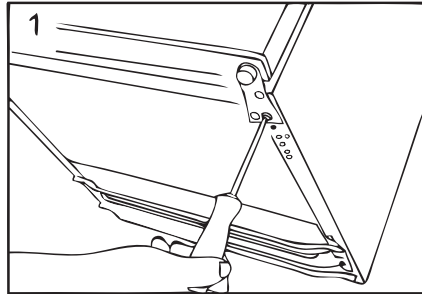

## **CLEANING YOUR BEER DISPENSER**

- Turn the temperature control to “OFF”, unplug the Beer Dispenser, and remove the contents.
- Wash the inside surfaces with a warm water and baking soda solution. The solution should be about 2 tablespoons of baking soda to a quart of water.
- Wash the shelves and stand with a mild detergent solution.
- Wipe down any electrical controls with a dry cloth.
- Wash the outside cabinet with warm water and mild liquid detergent. Rinse well and wipe dry with a clean soft cloth.

## **VACATION TIME**

- Short vacations: Leave the Beer Dispenser operating during vacations of less than three weeks.
- Long vacations: If the appliance will not be used for several months, remove all contents and unplug the power cord. Clean and dry the interior thoroughly. To prevent odor and mold growth, leave the door open slightly.

## **MOVING YOUR BEER DISPENSER**

- Remove all the contents.
- Securely tape down all loose items inside your Beer Dispenser.
- Tape the door shut.
- Be sure the Beer Dispenser stays secure in the upright position during transportation. Also protect outside of Beer Dispenser with a blanket or similar item.

# Parts Breakdown

Model BC-CN-0152 46500

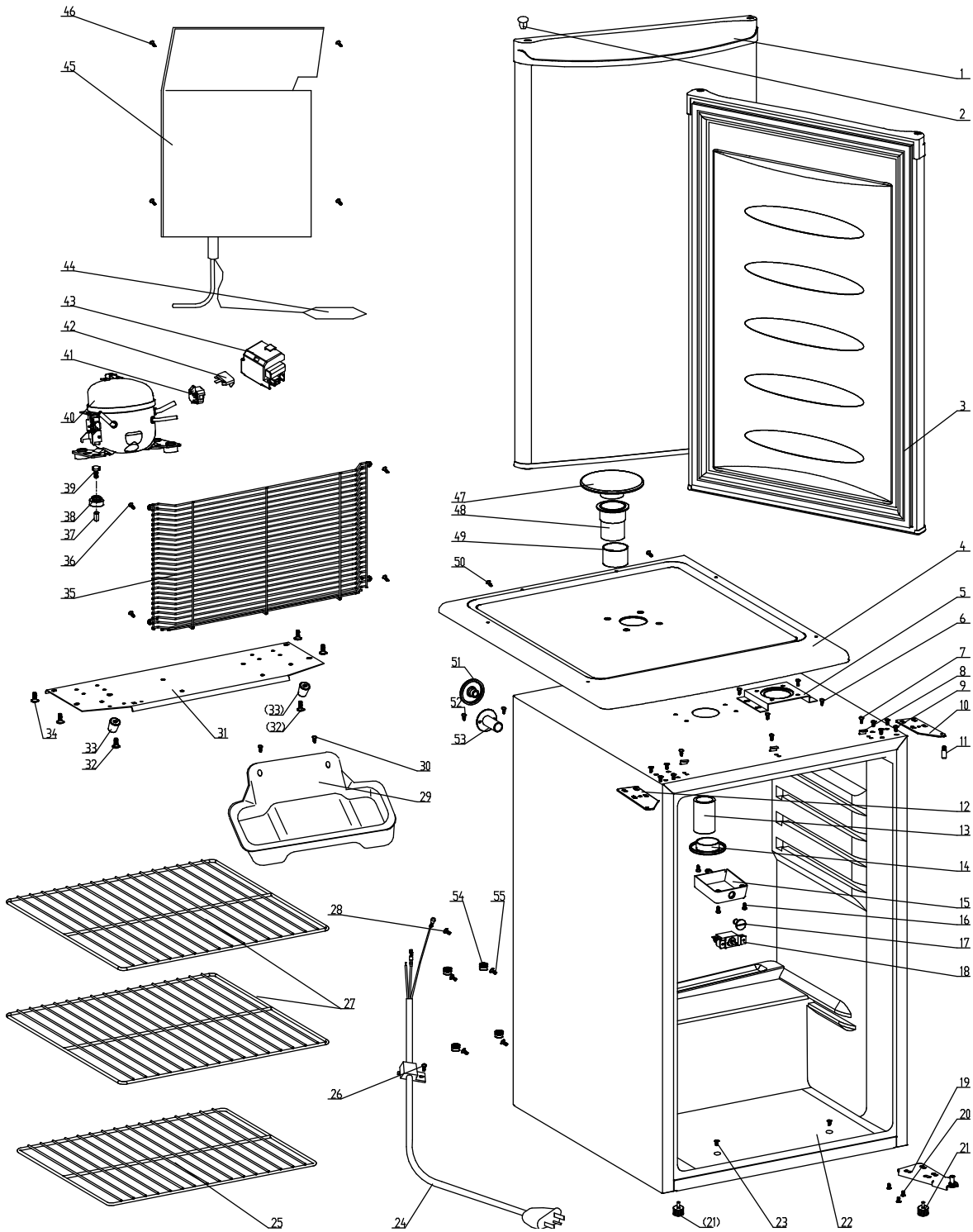

# Parts Breakdown

Model BC-CN-0152 46500

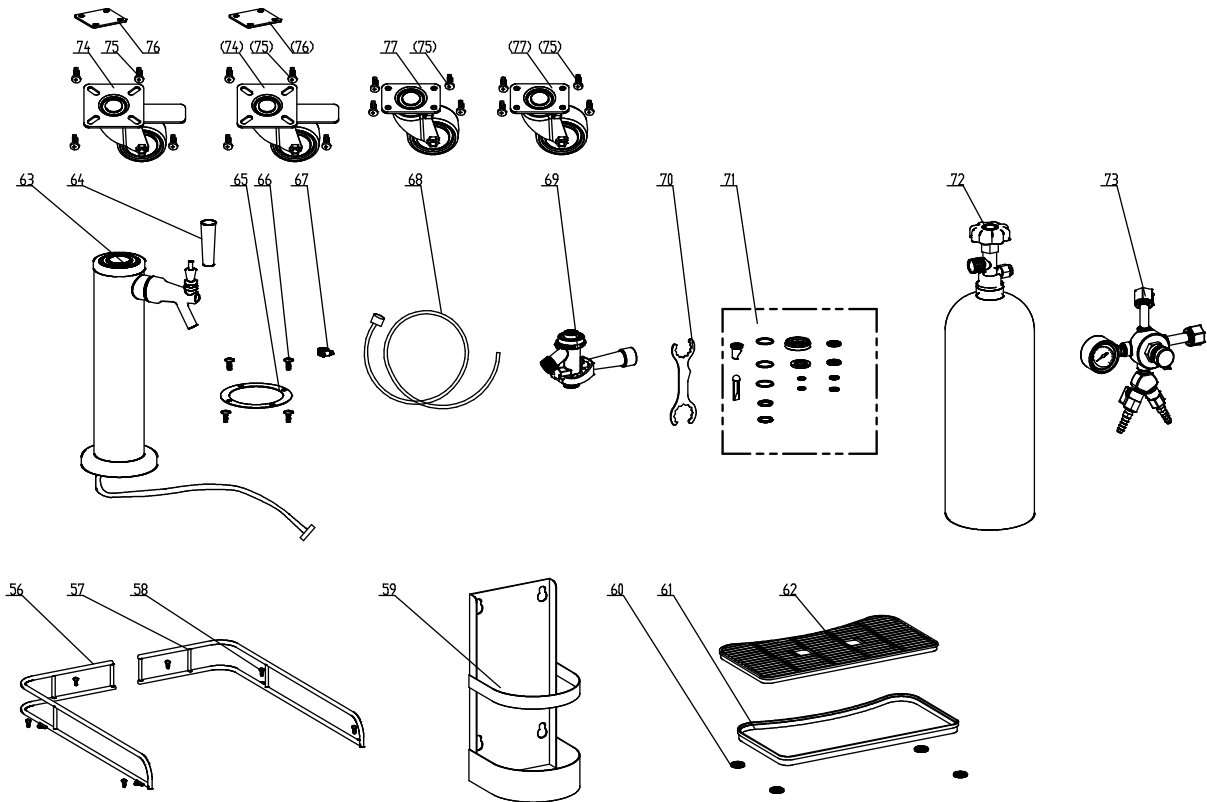

# Parts Breakdown

## Model BC-CN-0152 46500

Item No.	Description	Position	Item No.	Description	Position	Item No.	Description	Position
AG054	Door Assembly for 46500	1	AG080	Big Steel Wire Shelf for 46500	27	AG106	CO2 Hose Bushing for 46500	53
AG055	Hinge Plug for 46500	2	AG081	Grounding Screw for 46500	28	AG107	CO2 Cylinder Gasket for 46500	54
AG056	Door Gasket for 46500	3	AG082	Drip Tray Assembly for 46500	29	AG108	CO2 Cylinder Bracket Screw for 46500	55
AG057	Worktop for 46500	4	AG083	Drip Tray Screw for 46500	30	AG109	Left Worktop Rail for 46500	56
AG058	Fixing Plate for 46500	5	AG084	Compressor Support for 46500	31	AG110	Right Worktop Rail for 46500	57
AG059	Fixing Plate Screw for 46500	6	AG085	Foot Screw for 46500	32	AG111	Worktop Rail Screw for 46500	58
AG060	Hook Screw for 46500	7	AG086	Foot for 46500	33	AG112	CO2 Cylinder Bracket for 46500	59
AG061	Worktop Screw for 46500	8	AG087	Compressor Support Screw for 46500	34	AG113	Slide-Proof Pad for 46500	60
AG062	Upper Hinge Screw Assembly for 46500	9	AG088	Compressor Protector Cover for 46500	35	AG114	Beer Tray for 46500	61
AG063	Right Upper Hinge for 46500	10	AG089	Compressor Cover Screw for 46500	36	AG115	Beer Tray Shelf for 46500	62
AG064	Upper Door Spindle for 46500	11	AG090	Compressor Bushing for 46500	37	AG116	3" Tower Set (Single Outlet) for 46500	63
AG065	Left Upper Hinge for 46500	12	AG091	Compressor Rubber Washer for 46500	38	AG117	Plastic Handle for 46500	64
AG066	Beer Sleeve for 46500	13	AG092	Compressor Screw for 46500	39	AG118	Beer Tower Washer for 46500	65
AG067	Beer Dispenser Outer Collar C for 46500	14	AG093	Compressor for 46500	40	AG119	Beer Tower Fixed Screw for 46500	66
AG068	Thermostat Box for 46500	15	AG094	PTC Starter for 46500	41	AG120	Clamp for 46500	67
AG069	Thermostat Box Screw for 46500	16	AG095	Overload Protector for 46500	42	AG121	Gas Line for 46500	68
AG070	Thermostat Knob for 46500	17	AG096	PTC Cover for 46500	43	AG122	D-Keg Coupler for 46500	69
AG071	Thermostat for 46500	18	AG097	Filter for 46500	44	AG123	Spanner for 46500	70
AG072	Bottom Hinge Assembly for 46500	19	AG098	Evaporator for 46500	45	AG124	Spare Parts for 46500	71
AG073	Bottom Hinge Screw Assembly for 46500	20	AG099	Evaporator Screw for 46500	46	AG125	2.5 LBS CO2 Cylinder + Valve for 46500	72
AG074	Adjustable Foot for 46500	21	AG100	Beer Cover (Silk Printing) for 46500	47	AG126	CO2 Regulator (Single) for 46500	73
AG075	Beer Tank Support Rack for 46500	22	AG101	Beer Dispenser Outer Collar A for 46500	48	AG127	Castors (with Skid) for 46500	74
AG076	Beer Tank Support Rack Screw for 46500	23	AG102	Beer Dispenser Outer Collar for 46500	49	AG128	Castors Screw for 46500	75
AG077	Power Supply Cord Assembly for 46500	24	AG103	Worktop Screw for 46500	50	AG129	Castors Backing Plate for 46500	76
AG078	Small Steel Wire Shelf for 46500	25	AG104	Sleeve Plug for 46500	51	AG130	Castors for 46500	77
AG079	Wire Clamp Screw for 46500	26	AG105	CO2 Hose Bushing Screw for 46500	52			

# Electrical Schematics

Model BC-CN-0152 46500

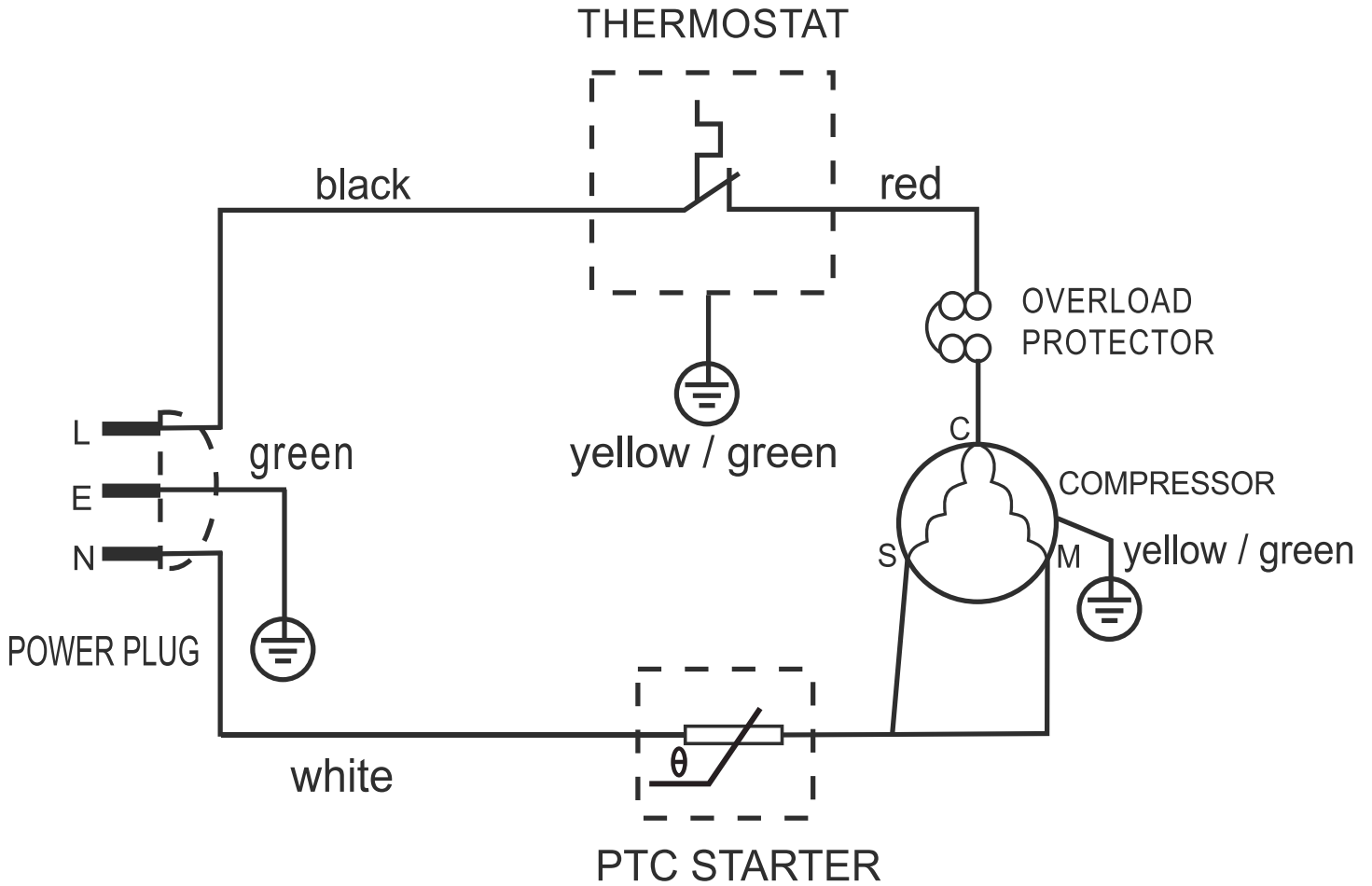









# Warranty Registration

Thank you for purchasing an Omcan product. To register your warranty for this product, complete the information below, tear off the card at the perforation and then send to the address specified below. You can also register online by visiting:

Merci d'avoir acheté un produit Omcan. Pour enregistrer votre garantie pour ce produit, complétez les informations ci-dessous, détachez la carte au niveau de la perforation, puis l'envoyer à l'adresse spécifiée ci-dessous. Vous pouvez également vous inscrire en ligne en visitant:

Gracias por comprar un producto Omcan usted. Para registrar su garantía para este producto, complete la información a continuación, cortar la tarjeta en la perforación y luego enviarlo a la dirección indicada a continuación. También puede registrarse en línea en:

<https://omcan.com/warranty-registration/>

For mailing in Canada

Pour postale au Canada

Por correo en Canadá

**OMCAN**

PRODUCT WARRANTY REGISTRATION

3115 Pepper Mill Court,

Mississauga, Ontario

Canada, L5L 4X5

For mailing in the US

Pour diffusion aux États-Unis

Por correo en los EE.UU.

**OMCAN**

PRODUCT WARRANTY REGISTRATION

4450 Witmer Industrial Estates, Unit 4,

Niagara Falls, New York

USA, 14305

*or email to: [service@omcan.com](mailto:service@omcan.com)*



Purchaser's Information

Name: \_\_\_\_\_

Address: \_\_\_\_\_

City: \_\_\_\_\_ Province or State: \_\_\_\_\_ Postal or Zip: \_\_\_\_\_

Country: \_\_\_\_\_

Dealer from which Purchased: \_\_\_\_\_

Dealer City: \_\_\_\_\_ Dealer Province or State: \_\_\_\_\_

Invoice: \_\_\_\_\_

Model Name: \_\_\_\_\_ Model Number: \_\_\_\_\_

Machine Description: \_\_\_\_\_

Date of Purchase (MM/DD/YYYY): \_\_\_\_\_

Would you like to extend the warranty?  Yes  No

Company Name: \_\_\_\_\_

Telephone: \_\_\_\_\_

Email Address: \_\_\_\_\_

Type of Company:

Restaurant  Bakery  Deli

Butcher  Supermarket  Caterer

Institution (specify): \_\_\_\_\_

Other (specify): \_\_\_\_\_

Serial Number: \_\_\_\_\_

Date of Installation (MM/DD/YYYY): \_\_\_\_\_

**Thank you for choosing Omcan | Merci d'avoir choisi Omcan | Gracias por elegir Omcan**



Since 1951 Omcan has grown to become a leading distributor of equipment and supplies to the North American food service industry. Our success over these many years can be attributed to our commitment to strengthen and develop new and existing relationships with our valued customers and manufacturers. Today with partners in North America, Europe, Asia and South America, we continually work to improve and grow the company. We strive to offer customers exceptional value through our qualified local sales and service representatives who provide convenient access to over 6,500 globally sourced products.

---

Depuis 1951 Omcan a grandi pour devenir un des “leaders” de la distribution des équipements et matériel pour l’industrie des services alimentaires en Amérique du Nord. Notre succès au cours de ces nombreuses années peut être attribué à notre engagement à renforcer et à développer de nouvelles et existantes relations avec nos clients et les fabricants de valeur. Aujourd’hui avec des partenaires en Amérique du Nord, Europe, Asie et Amérique du Sud, nous travaillons continuellement à améliorer et développer l’entreprise. Nous nous efforçons d’offrir à nos clients une valeur exceptionnelle grâce à nos ventes locales qualifiées et des représentants de service qui offrent un accès facile à plus de 6500 produits provenant du monde entier.

---

Desde 1951 Omcan ha crecido hasta convertirse en un líder en la distribución de equipos y suministros de alimentos en América del Norte industria de servicios. Nuestro éxito en estos años se puede atribuir a nuestro compromiso de fortalecer y desarrollar nuevas relaciones existentes con nuestros valiosos clientes y fabricantes. Hoy con socios de América del Norte, Europa, Asia y América del Sur, que trabajan continuamente para mejorar y crecer la empresa. Nos esforzamos por ofrecer a nuestros clientes valor excepcional a través de nuestro local de ventas y representantes de los servicios que proporcionan un fácil acceso a más de 6,500 productos con origen a nivel mundial.

