



Electric Griddles

Models CE-CN-3000, 4400

Items 34869, 34870

Instruction Manual



Revised - 04/22/2025



Toll Free: 1-800-465-0234
Fax: 905-607-0234
Email: service@omcan.com
www.omcan.com

**Power cord and plug not included; must be installed by a certified electrician.*



Table of Contents

Model CE-CN-3000 / Model CE-CN-4400

Section	Page
General Information -----	3 - 4
Safety and Warranty -----	4 - 5
Technical Specifications -----	6
Operation -----	6
Maintenance -----	6
Troubleshooting -----	7
Parts Breakdown -----	8 - 10
Electrical Schematics -----	11 - 12
Notes -----	13 - 14
Warranty Registration -----	15



General Information

Omcan Manufacturing and Distributing Company Inc., Food Machinery of America, Inc. dba Omcan and Omcan Inc. are not responsible for any harm or injury caused due to any person's improper or negligent use of this equipment. The product shall only be operated by someone over the age of 18, of sound mind, and not under the influence of any drugs or alcohol, who has been trained in the correct operation of this machine, and is wearing authorized, proper safety clothing. Any modification to the machine voids any warranty, and may cause harm to individuals using the machine or in the vicinity of the machine while in operation.

CHECK PACKAGE UPON ARRIVAL

Upon receipt of an Omcan shipment please inspect for external damage. If no damage is evident on the external packaging, open carton to ensure all ordered items are within the box, and there is no concealed damage to the machine. If the package has suffered rough handling, bumps or damage (visible or concealed), please note it on the bill of lading before accepting the delivery and contact Omcan within 24 hours, so we may initiate a claim with the carrier. A detailed report on the extent of the damage caused to the machine must be filled out within three days, from the delivery date shown in the shipping documents. Omcan has no recourse for damaged products that were shipped collect or third party.

Before operating any equipment, always read and familiarize yourself with all operation and safety instructions.

Omcan would like to thank you for purchasing this machine. It's of the utmost importance to save these instructions for future reference. Also save the original box and packaging for shipping the equipment if servicing or returning of the machine is required.

Omcan Fabrication et distribution Compagnie Limitée et Food Machinery d'Amérique, dba Omcan et Omcan Inc. ne sont pas responsables de tout dommage ou blessure causé du fait que toute personne ait utilisé cet équipement de façon irrégulière. Le produit ne doit être exploité que par quelqu'un de plus de 18 ans, saine d'esprit, et pas sous l'influence d'une drogue ou d'alcool, qui a été formé pour utiliser cette machine correctement, et est vêtu de vêtements de sécurité appropriés. Toute modification de la machine annule toute garantie, et peut causer un préjudice à des personnes utilisant la machine ou des personnes à proximité de la machine pendant son fonctionnement.

VÉRIFIEZ LE COLIS DÈS RÉCEPTION

Dès réception d'une expédition d'Omcan veuillez inspecter pour dommages externes. Si aucun dommage n'est visible sur l'emballage externe, ouvrez le carton afin de s'assurer que tous les éléments commandés sont dans la boîte, et il n'y a aucun dommage dissimulé à la machine. Si le colis n'a subi aucune mauvaises manipulations, de bosses ou de dommages (visible ou cachée), notez-le sur le bond de livraison avant d'accepter la livraison et contactez Omcan dans les 24 heures qui suivent, pour que nous puissions engager une réclamation auprès du transporteur. Un rapport détaillé sur l'étendue des dommages causés à la machine doit être rempli dans un délai de trois jours, à compter de la date de livraison indiquée dans les documents d'expédition. Omcan n'a aucun droit de recours pour les produits endommagés qui ont été expédiés ou cueilli par un tiers transporteur.

Avant d'utiliser n'importe quel équipement, toujours lire et vous familiariser avec toutes les opérations et les

General Information

consignes de sécurité.

Omcan voudrais vous remercier d'avoir choisi cette machine. Il est primordial de conserver ces instructions pour une référence ultérieure. Également conservez la boîte originale et l'emballage pour l'expédition de l'équipement si l'entretien ou le retour de la machine est nécessaire.

Omcan Empresa De Fabricacion Y Distribucion Inc. Y Maquinaria De Alimentos De America, Inc. dba Omcan y Omcan Inc. no son responsables de ningun daño o perjuicio causado por cualquier persona inadecuada o el uso descuidado de este equipo. El producto solo podra ser operado por una persona mayor de 18 años, en su sano juicio y no bajo alguna influencia de droga o alcohol, y que este ha sido entrenado en el correcto funcionamiento de esta máquina, y ésta usando ropa apropiada y autorizada. Cualquier modificación a la máquina anula la garantía y puede causar daños a las personas usando la máquina mientras esta en el funcionamiento.

REVISE EL PAQUETE A SU LLEGADA

Tras la recepcion de un envio Omcan favor inspeccionar daños externos. Si no hay daños evidentes en el empaque exterior, Habra el carton para asegurarse que todos los articulos solicitados estén dentro de la caja y no encuentre daños ocultos en la máquina. Si el paquete ha sufrido un manejo de poco cuidado, golpes o daños (visible o oculto) por favor anote en la factura antes de aceptar la entrega y contacte Omcan dentro de las 24 horas, de modo que podamos iniciar una reclamación con la compañía. Un informe detallado sobre los daños causados a la máquina debe ser llenado en el plazo de tres días, desde la fecha de entrega que se muestra en los documentos de envío. Omcan no tiene ningun recurso por productos dañados que se enviaron a recoger por terceros.

Antes de utilizar cualquier equipo, siempre lea y familiarizarse con todas las instrucciones de funcionamiento y seguridad.

Omcan le gustaría darle las gracias por la compra de esta máquina. Es de la mayor importancia para salvar estas instrucciones para futuras consultas. Además, guarda la caja original y el embalaje para el envío del equipo si servicio técnico o devolución de la máquina que se requiere.

Safety and Warranty

CAUTION

These griddles are shipped without a plug and power cord, for your safety, ensure that only a certified electrician installs the griddle.

- All operators must strictly observe the guidelines for safe use of electrical machines.
- The owner should assure only those who meet the following condition(s) are allowed to operate the equipment:
 - Those specially trained and strictly adhere to operation rules.

Safety and Warranty

- All operations should be carried out only in safe conditions. Any failure to do so can cause danger to yourself. Any defects should be repaired immediately by a qualified technician. Before operating the machine, all safety devices and removable parts should be inspected; and only after they have been tested, can the machine be operated. Prior to any maintenance or service, the machine must be powered off and unplugged; do not open the machine; all components must be installed in accordance with regulations, and by qualified technicians.
- Shut down and unplug the equipment and make sure the equipment has cooled down before any maintenance.
- Periodical maintenance checks should be implemented to ensure safe operation.
- Do not touch the hot surface when it is in operation.

Warning

User must only use a dry towel and small amounts of mild cleaner and water to clean the machine. Flushing with water is prohibited, parts will become damp and influence the safe performance of the machine.

RESIDENTIAL USERS: vendor assumes no liability for parts or labor coverage for component failure or other damages resulting from installation in non-commercial or residential applications. The right is reserved to deny shipment for residential usage; if this occurs, you will be notified as soon as possible.

1 YEAR PARTS AND LABOUR BENCH WARRANTY

Within the warranty period, contact Omcan Inc. At 1-800-465-0234 to schedule a drop off to either an Omcan authorized service depot in the area, or to an Omcan Service warehouse to repair the equipment.

Unauthorized maintenance will void the warranty. Warranty covers electrical and part failures, not improper use.

Please see <https://omcan.com/disclaimer> for complete info.

WARNING:

The packaging components are classified as normal solid urban waste and can therefore be disposed of without difficulty.

In any case, for suitable recycling, we suggest disposing of the products separately (differentiated waste) according to the current norms.

DO NOT DISCARD ANY PACKAGING MATERIALS IN THE ENVIRONMENT!

Technical Specifications

Model	CE-CN-3000	CE-CN-4400
Item Number	34869	34870
Power	3 kW	4.4 kW
Temperature Range	0 - 300°C / 32 - 572°F	
Cooking Area	21.7" x 13.7" / 552 x 349mm	28.5" x 15.7" / 724 x 400mm
Electrical	220V / 60Hz / 1	
Weight	50.7 lbs. / 23 kgs.	70.5 lbs. / 32 kgs.
Dimensions	17.8" x 21.7" x 9" / 451 x 552 x 229mm	19.8" x 28.7" x 9" / 502 x 730 x 229mm

Operation

1. Place the machine on a non-flammable, secure, level and safe surface, a minimum 4"/10cm from a wall or other object. Connect the power to the correct electrical output. The green indication light will turn on.
2. Adjust the working temperature to the desired setting. The working light will illuminate yellow, the heating plate is working. When the temperature reaches the desired level, the yellow light will turn off.
3. After testing the temperature, the user can re-adjust the thermostat knob, establishing the desired cooking temperature.
4. The user can start cooking on the grill. When the temperature lowers, the thermostat will engage and unit will start reheating automatically.
5. When the food is cooked, the user can remove it using a serving tool. Avoid using metal tools to remove the food, otherwise it will scratch and damage the surface of heating plate.
6. The small drip box at the bottom of the grill will collect the waste food and oil. It should be cleaned out frequently to avoid spillage or fire.

Maintenance

CLEANING

To maintain the appearance and increase the life of your griddle, clean and oil it daily. DO NOT clean equipment with steel wool.

1. Allow the equipment to cool completely before cleaning.
2. Using a wire brush, scrape the griddle plate to remove any food residue.
3. Do not clean the griddle plate with water, only scrape off food residue and lightly grease the plate with oil.
4. Empty and clean the drip box.

Troubleshooting

Problems	Reason	Solution
Switch is turned on but it is not heating.	Electric wire.	Check the wire.
	Electric contact.	Ensure electrical socket is working.
Temperature can't be controlled.	Wrong wire contacting.	Call Omcan.
	Temperature failure.	Call Omcan.

Parts Breakdown

Model CE-CN-3000 34869

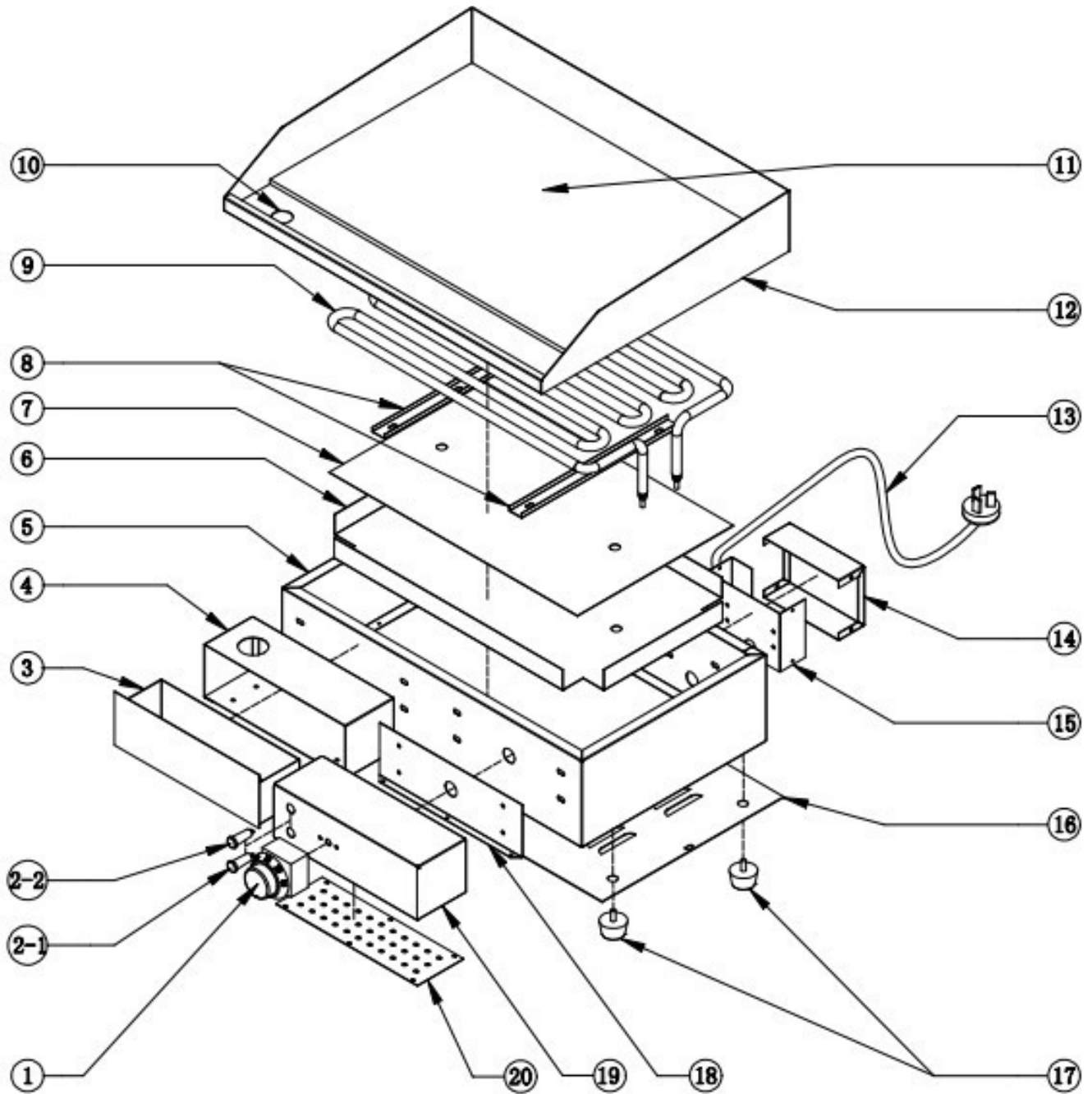

Parts Breakdown

Model CE-CN-4400 34870

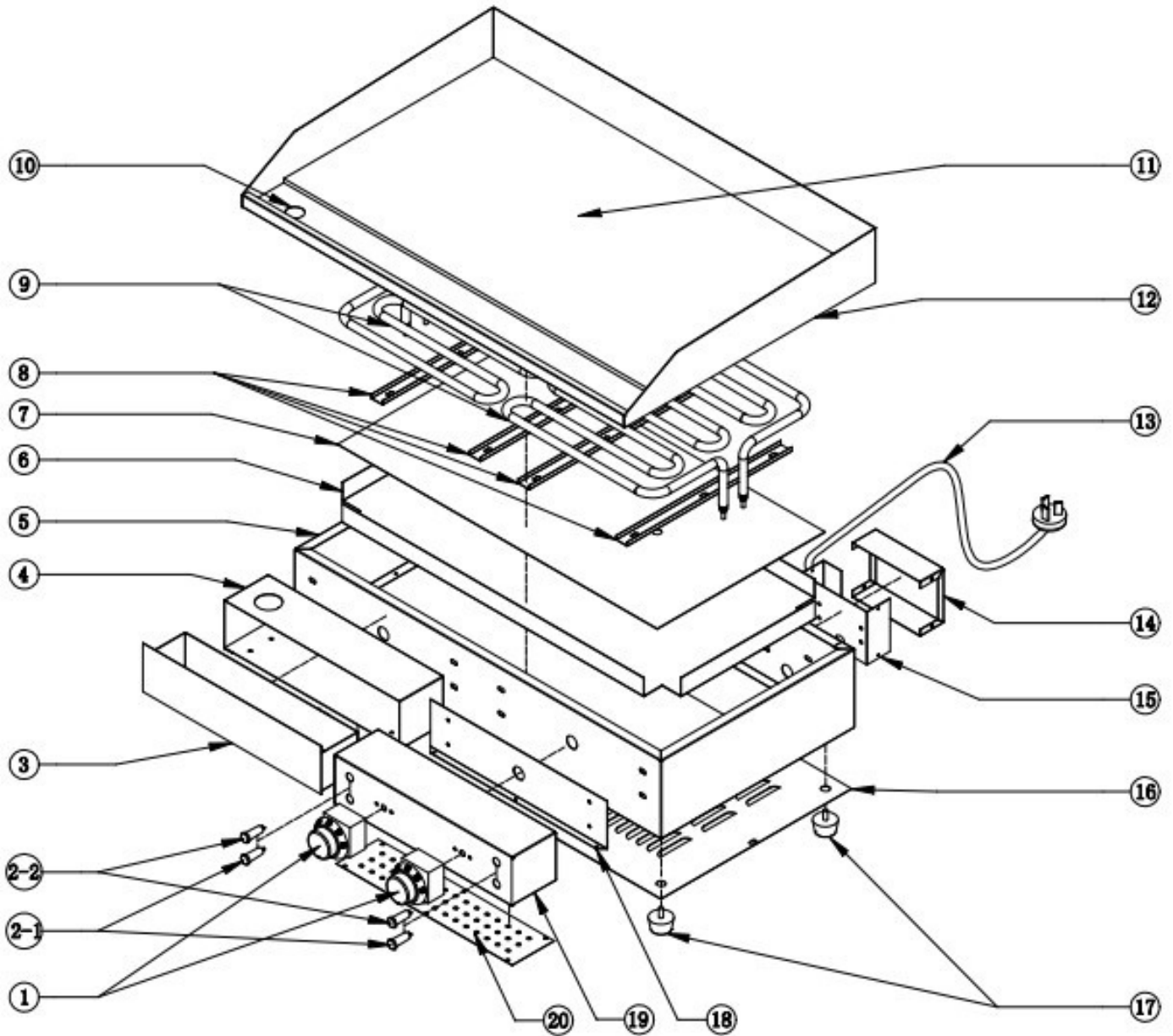

Parts Breakdown

Model CE-CN-3000 34869

Item No.	Description	Position	Item No.	Description	Position	Item No.	Description	Position
39774	Thermostat for 34869	1	40038	Heater Cover for 34869	7	40045	Bottom Cover for 34869	16
44718	Power Indicator Green for 34869	2-1	40039	Heater Fixed Stick for 34869	8	40046	Rubber Feet for 34869	17
40033	Power Indicator Yellow for 34869	2-2	40040	Heater for 34869	9	40047	Control Box Inner Cover for 34869	18
39812	Grease Tray for 34869	3	40041	Heating Plate Assembly for 34869	10 - 12	40048	Control Box for 34869	19
40035	Grease Tray Support for 34869	4	40042	Power Cord for 34869	13	40049	Control Box Bottom Cover for 34869	20
40036	Frame for 34869	5	40043	Terminal Box Cover for 34869	14			
40037	Insulation Cover for 34869	6	40044	Terminal Box for 34869	15			

Model CE-CN-4400 34870

Item No.	Description	Position	Item No.	Description	Position	Item No.	Description	Position
39774	Thermostat for 34870	1	40052	Insulation Cover for 34870	6	40044	Terminal Box for 34870	15
44718	Power Indicator Green for 34870	2-1	40053	Heater Cover for 34870	7	40056	Bottom Cover for 34870	16
40033	Power Indicator Yellow for 34870	2-2	40054	Heater Fixed Stick for 34870	8	40046	Rubber Feet for 34870	17
39813	Grease Tray for 34870	3	39852	Heater for 34870	9	40057	Control Box Inner Cover for 34870	18
40050	Grease Tray Support for 34870	4	40055	Heating Plate Assembly for 34870	10 - 12	40058	Control Box for 34870	19
40051	Frame for 34870	5	40043	Terminal Box Cover for 34870	14	40059	Control Box Bottom Cover for 34870	20

Electrical Schematics

Model CE-CN-3000 34869

220V ~ XT

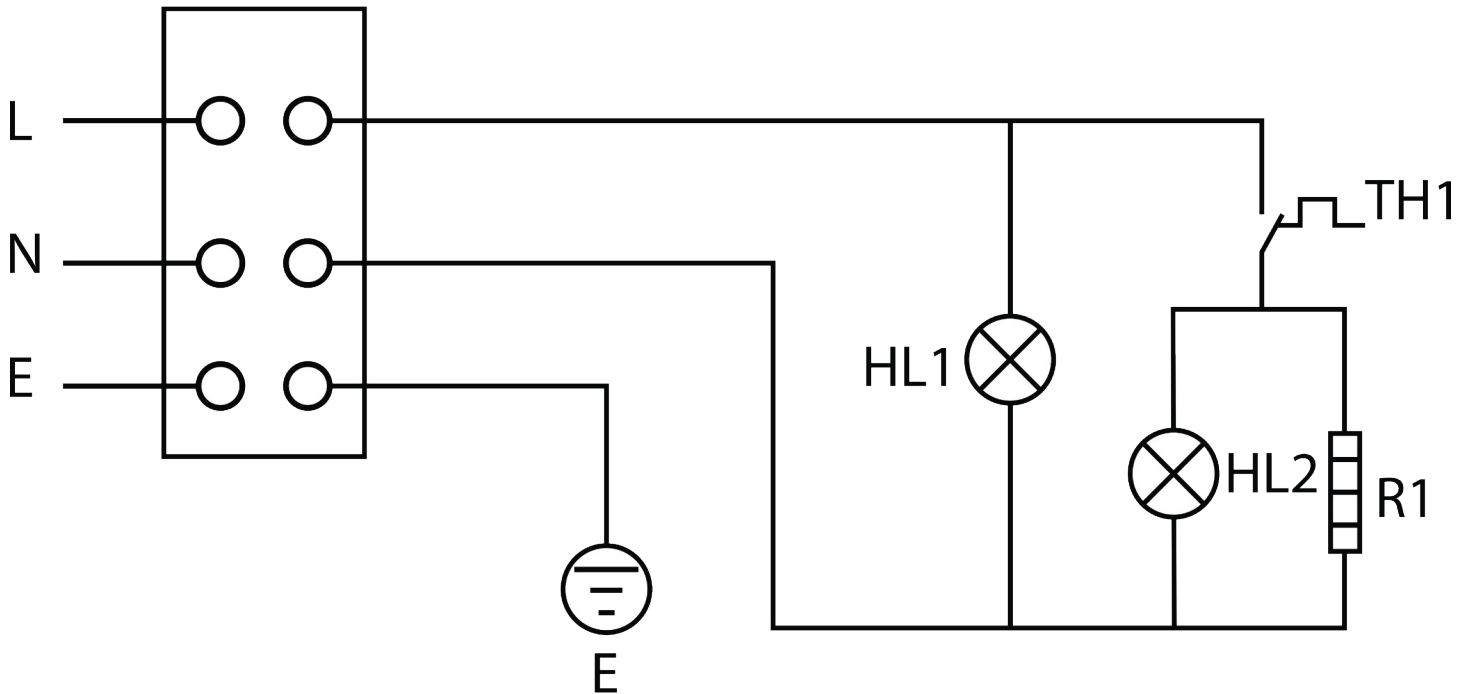

XT -- Terminal

R1 -- Heater

HL1, HL2 -- Indicator

TH1 -- Thermostat

Electrical Schematics

Model CE-CN-4400 34870

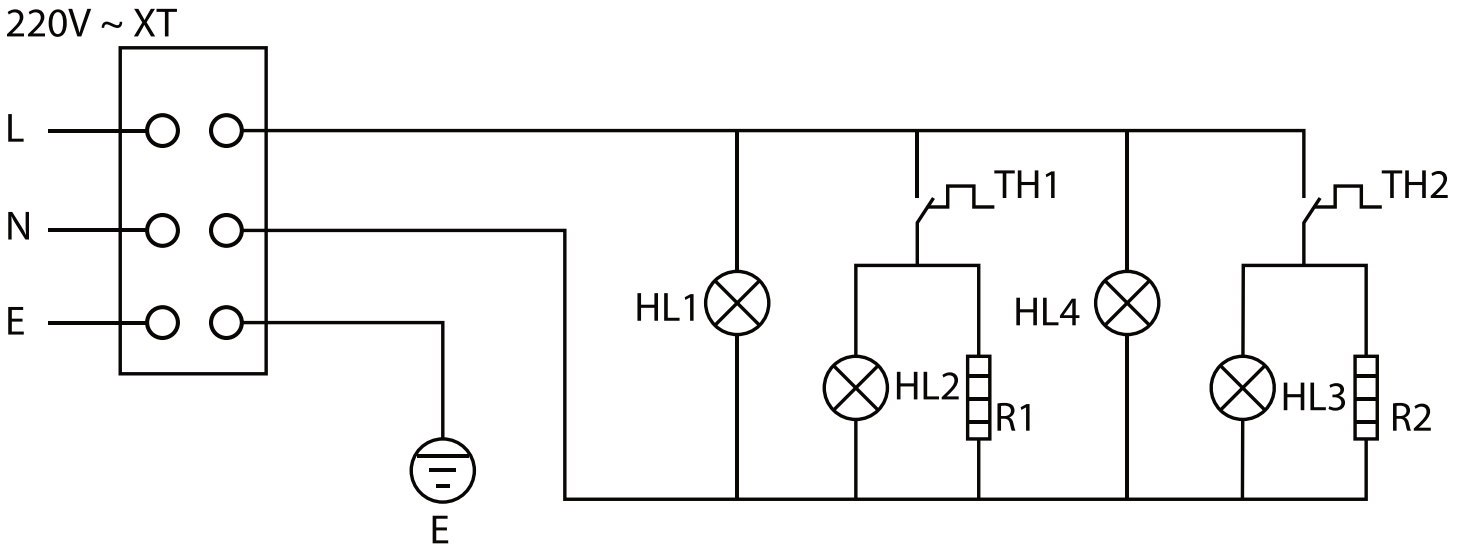

XT -- Terminal

R1, R2 -- Heater

HL1, HL2, HL3, HL4 -- Indicator

TH1, TH2 -- Thermostat



Warranty Registration

Thank you for purchasing an Omcan product. To register your warranty for this product, complete the information below, tear off the card at the perforation and then send to the address specified below. You can also register online by visiting:

Merci d'avoir acheté un produit Omcan. Pour enregistrer votre garantie pour ce produit, complétez les informations ci-dessous, détachez la carte au niveau de la perforation, puis l'envoyer à l'adresse spécifiée ci-dessous. Vous pouvez également vous inscrire en ligne en visitant:

Gracias por comprar un producto Omcan usted. Para registrar su garantía para este producto, complete la información a continuación, cortar la tarjeta en la perforación y luego enviarlo a la dirección indicada a continuación. También puede registrarse en línea en:

<https://omcan.com/warranty-registration/>

For mailing in Canada

Pour postale au Canada

Por correo en Canadá

For mailing in the US

Pour diffusion aux États-Unis

Por correo en los EE.UU.

OMCAN

PRODUCT WARRANTY REGISTRATION

3115 Pepper Mill Court,
Mississauga, Ontario
Canada, L5L 4X5

OMCAN

PRODUCT WARRANTY REGISTRATION

4450 Witmer Industrial Estates, Unit 4,
Niagara Falls, New York
USA, 14305

or email to: service@omcan.com



Purchaser's Information

Name: _____

Address: _____

City: _____ Province or State: _____ Postal or Zip: _____

Country: _____

Dealer from which Purchased: _____

Dealer City: _____ Dealer Province or State: _____

Invoice: _____

Model Name: _____ Model Number: _____

Machine Description: _____

Date of Purchase (MM/DD/YYYY): _____

Would you like to extend the warranty? Yes No

Company Name: _____

Telephone: _____

Email Address: _____

Type of Company:

Restaurant Bakery Deli

Butcher Supermarket Caterer

Institution (specify): _____

Other (specify): _____

Serial Number: _____

Date of Installation (MM/DD/YYYY): _____

Thank you for choosing Omcan | Merci d'avoir choisi Omcan | Gracias por elegir Omcan



Since 1951 Omcan has grown to become a leading distributor of equipment and supplies to the North American food service industry. Our success over these many years can be attributed to our commitment to strengthen and develop new and existing relationships with our valued customers and manufacturers. Today with partners in North America, Europe, Asia and South America, we continually work to improve and grow the company. We strive to offer customers exceptional value through our qualified local sales and service representatives who provide convenient access to over 6,500 globally sourced products.

Depuis 1951 Omcan a grandi pour devenir un des “leaders” de la distribution des équipements et matériel pour l’industrie des services alimentaires en Amérique du Nord. Notre succès au cours de ces nombreuses années peut être attribué à notre engagement à renforcer et à développer de nouvelles et existantes relations avec nos clients et les fabricants de valeur. Aujourd’hui avec des partenaires en Amérique du Nord, Europe, Asie et Amérique du Sud, nous travaillons continuellement à améliorer et développer l’entreprise. Nous nous efforçons d’offrir à nos clients une valeur exceptionnelle grâce à nos ventes locales qualifiées et des représentants de service qui offrent un accès facile à plus de 6500 produits provenant du monde entier.

Desde 1951 Omcan ha crecido hasta convertirse en un líder en la distribución de equipos y suministros de alimentos en América del Norte industria de servicios. Nuestro éxito en estos años se puede atribuir a nuestro compromiso de fortalecer y desarrollar nuevas relaciones existentes con nuestros valiosos clientes y fabricantes. Hoy con socios de América del Norte, Europa, Asia y América del Sur, que trabajan continuamente para mejorar y crecer la empresa. Nos esforzamos por ofrecer a nuestros clientes valor excepcional a través de nuestro local de ventas y representantes de los servicios que proporcionan un fácil acceso a más de 6,500 productos con origen a nivel mundial.

