



# TRENTO

## 2025

- Warewashing Equipment • Bar & Cafe Equipment • Cooking Equipment •
- Dough Processing • Food Preservation • Food Processing • Meat Processing •

[www.trentoequipment.com](http://www.trentoequipment.com)  
1-833-487-3686

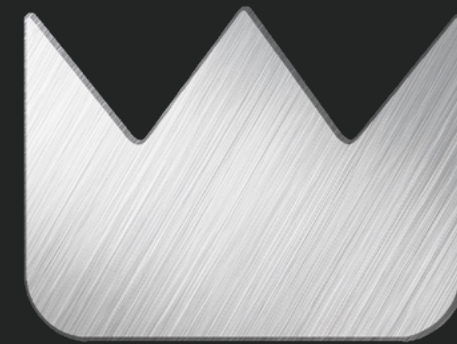

---

## Elevating Culinary Excellence

---

**BUSINESS HOURS**

Monday to Friday  
8:30am - 8:00pm EST

**PHONE**

1-833-487-3686

**EMAIL**

General Inquiries  
[sales@trentoequipment.com](mailto:sales@trentoequipment.com)

**WEBSITE**

[www.trentoequipment.com](http://www.trentoequipment.com)

# W

elcome to Trento, an exclusive line, dedicated to revolutionizing the food service industry with unparalleled precision and innovation. Trento brings you cutting-edge equipment designed for professional chefs who demand excellence in every aspect of their culinary endeavors.

At Trento, we believe in the power of innovation to transform the way we cook and create. Our state-of-the-art technology and meticulously crafted tools are engineered to deliver unmatched performance, enabling chefs to push the boundaries of their craft. With Trento, you gain access to a world of possibilities, where precision meets creativity, and every dish becomes a masterpiece.

## Featured Brands



### MEMBERSHIPS



## Trento's Vision & Values

A rich heritage of quality and service excellence forms the backbone of Trento. Our products are a testament to our commitment to providing reliable, high-quality equipment that meets the evolving needs of the food service industry.

## Benefits

High quality European sourced products at competitive prices

Comprehensive network and service providers throughout North America

Largest selection of premium European products in the industry

Fast local delivery from one of our three distribution centers

Access to well-known brand names

A team of helpful and knowledgeable customer agents, who are ready to assist you between 8:30 am - 8:00pm EST



### Trento Protection Plan Extended Warranty Program

Investing in our extended warranty program means you'll receive peace of mind knowing your product is covered after the standard manufacturer's warranty expires. We'll make repairs on your covered product, including those made due to mechanical or electrical failure, at no cost to you. Your item will be serviced by an authorized Trento technician.

#### Hours

Monday to Friday  
8:30am - 8:00pm EST



Website  
[www.trentoequipment.com](http://www.trentoequipment.com)



Email  
[sales@trentoequipment.com](mailto:sales@trentoequipment.com)



Phone  
1-833-487-3686

#### SIGN UP

For our newsletter to get the latest updates & offers

FOLLOW US ON

# NORTH AMERICA DISTRIBUTION

# Trento Collection

With our network of warehouses and service providers, throughout North America, we are able to exceed you and your customers' delivery and service expectations.

Our friendly and knowledgeable sales and customer service teams are available from **8:30am to 8:00pm EST** to quickly provide you with the information you need.



An exclusive line, dedicated to revolutionizing the food service industry with unparalleled precision and innovation. Trento brings you cutting-edge equipment designed for professional chefs who demand excellence in every aspect of their culinary endeavors.

At Trento, we believe in the power of innovation to transform the way we cook and create. Our state-of-the-art technology and meticulously crafted tools are engineered to deliver unmatched performance, enabling chefs to push the boundaries of their craft. With Trento, you gain access to a world of possibilities, where precision meets creativity, and every dish becomes a masterpiece.

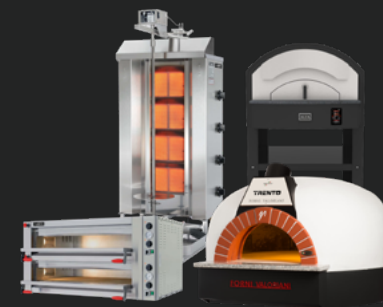

## Cooking Equipment

Discover Trento's top-tier Cooking Equipment for all your culinary needs. Premium pizza ovens, gyro grills bring authentic Mediterranean taste to your restaurant.



## Food Processing

From food processors to the high tech Pacojet, Trento has you covered from rustic dishes to complicated masterpieces. Unleashing culinary creativity has never been easier with Trento.



## Warewashing

Premium Kromo dishwashers lead the industry in precision cleaning and versatility. Built to last and effortless to maintain, they are the premier choice for commercial warewashing.

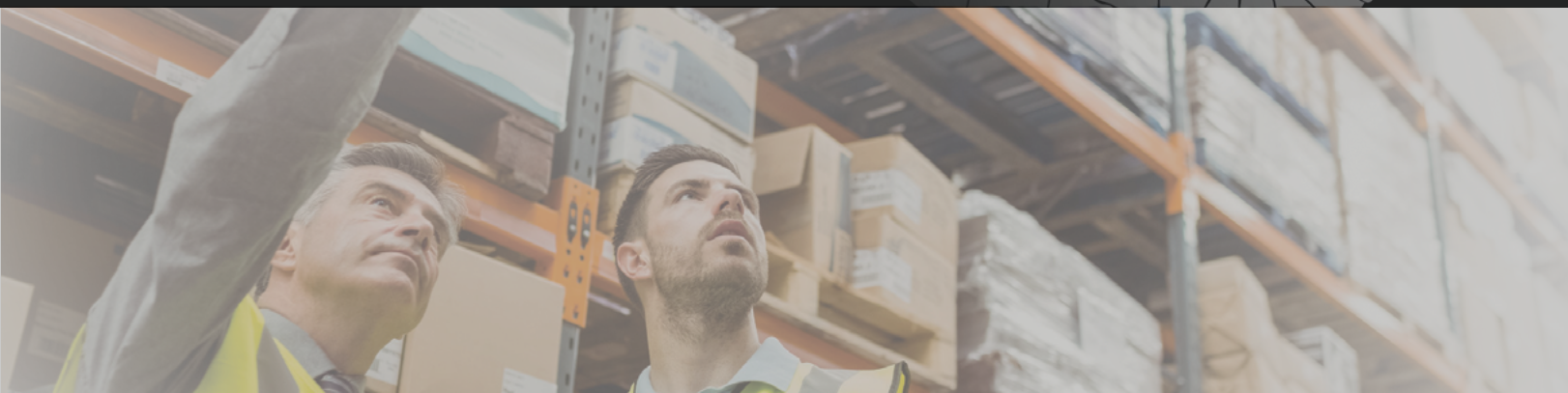

### CANADA

#### ONTARIO TORONTO

Head Office and Canadian  
Distribution Center

3115 Pepper Mill Court,  
Mississauga, Ontario,  
L5L 4X5, Canada

### USA

#### CALIFORNIA LOS ANGELES

Western USA  
Distribution Center

12854 E. Florence Avenue,  
Santa Fe Springs, California,  
90670, USA

### USA

#### NEW YORK BUFFALO

Eastern USA  
Distribution Center

4450 Witmer Industrial Estates, Unit 4,  
Niagara Falls, New York,  
14305, USA



## Blast Chillers

Trento blast chillers rapidly freeze food through high intensity cooling, resulting in fewer and smaller ice crystals and improves the texture of the frozen food once it is reheated.



## Beverage Solutions

From juicers to coffee grinders, and from creating to dispensing, Trento has all the solutions you need for every point of the journey.



## Meat Processing & Preservation

With Trento's professional butchery and aging equipment at your finger tips, you can deliver high quality aged meats, fish, and cheeses that'll be the envy of your competition.

# TABLE OF CONTENTS

01

## Warewashing Equipment

01 Dishwashers

02

## Bar & Cafe Equipment

09 Granita Dispensers  
11 Drink Dispensers  
15 Blenders, Shakers & Mixers  
19 Coffee Grinders  
21 Ice Shavers & Crushers  
25 Gelato Makers  
29 Juice Bar

03

## Cooking Equipment

53 Broilers & Gyro Machines  
57 Pizza Dome Ovens  
70 Pizza Conveyor Ovens  
73 Pizza Deck Ovens  
77 Panini Grills  
81 Pasta Cookers  
85 Patty Makers

04

## Dough Processing

89 Dough Mixers  
97 Dough Rollers  
99 Dough Rounders & Dividers  
103 Dough Sheeters  
105 Pasta Sheeters  
107 Pasta Extruders  
114 Ravioli Machine  
115 Pasta Die Guide

## Food Preservation

121 Cheese Drying and Seasoning  
123 Curing Cabinets - Fish  
129 Curing Cabinets - Meat  
143 Curing Cabinets - Salami  
149 Stagionello Accessories  
148 Curing Salts and Spices  
151 Vacuum Packaging

## Food Processing

169 Bread Graters  
171 Cheese Processing  
179 Food Processors  
181 Bowl Processors  
188 Immersion Blender  
189 Peelers  
192 Dry Grinders  
193 Tomato Squeezers  
195 Blast Chillers

## Meat Processing

200 Band Saws  
201 Bowl Cutters  
207 Meat Tenderizers  
208 Meat Grinders  
211 Meat Mixers  
215 Meat Slicers  
243 Slicer Guide  
245 Sausage Stuffers

253 Terms, Conditions, Warranty & Policy  
260 Index

05

06

07

# Warewashing Equipment

# 01



# KROMO

YOUR SMART WASH

Innovation,  
Performance,  
Hygiene.

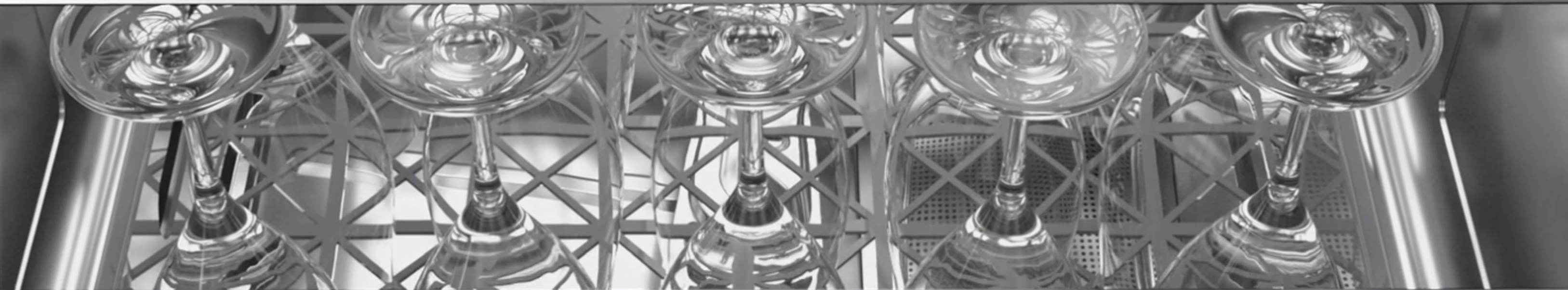
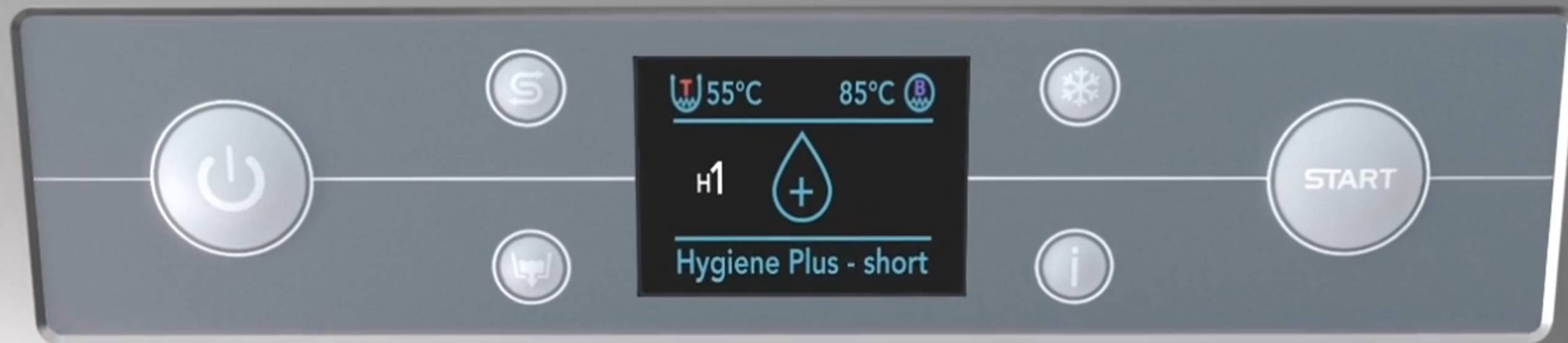



Dupla-50-USA (#49126)



Aqua-50-USA (#49125)

## Kromo Dupla/Aqua-50-USA High-Temperature Under-counter Dishwasher



Item	49126	49125
Model	DUPLA-50-USA	AQUA-50-USA
Rinsing Temperature (Set)	85 °C (185 °F)	85 °C (185 °F)
Tank Capacity	28.5 qt (27 L)	30.64 qt (29 L)
Tank Heating Element	2940 W	2940 W
Tank Temperature (Set)	71 °C (160 °F)	71 °C (160 °F)
Booster Capacity	6 qt (5.67 L)	6.04 qt (5.71 L)
Booster Heating Element	6530 W	6530 W
Inlet Water Pressure	25 - 90 PSI	25 - 95 PSI
Power	7090 W	7090 W
Electrical	220-240V / 60 Hz / 1 Ph	220-240V / 60 Hz / 1 Ph
Water Consumption / Cycle (rinse pressure 15 PSI)	2.96 qt (2.8 L)	2.96 qt (2.8 L)
Washing Cycles (sec)	1 (120)   2 (180)	1 (120)   2 (180)
Water Supply 131 °F Racks /H (*) (1)	30   20	30   20
Water Supply 50 °F Racks /H (*) (1)	21   20	21   20
Pump Power	560 W (359 qt/339 L per minute***)	560 W (359 qt/339 L per minute***)
Drain Pump	43 W hMAX 31.5" (800 mm) (43.12 qt / 40.8 L***)	43 W hMAX 31.5" (800 mm) (43.12 qt / 40.8 L***)
Noise	59.3 dB(A)	63 dB(A)
Rack Equipment	(1) Plastic Plates Basket (1) Large Mesh Glass Basket (1) Cutlery Basket	(1) Plastic Plates Basket (1) Large Mesh Glass Basket (1) Cutlery Basket
Rack Dimensions	20" x 20"	20" x 20"
Crockery Dimensions	Plates: 12.81" dia. Dishes Max Height: 12.18"	Plates: 13.62" dia. Dishes Max Height: 12.62"
Net Weight	150 lb (68 kg)	125 lb (56.5 kg)
Net Dimensions (WDH)	23.43" x 24" x 33.31"	23.25" x 23.62" x 33.43"

(\*) Standard Thermostat

(\*) In case of cold water supply and/or continuous washing, the rinse-water heating process might take more time than usual, until the proper rinse temperature is reached. For this reason, the wash-cycle total timing might result longer than set.

	Dupla	Aqua
Double Walled	✓	Door only
Wash Cycles	2	2
Overflow Drain System	✓	✓
Anti-Drop Roof Panel	✓	✓
Door Security Micro-switch	✓	✓
Pressed Basket Supports	✓	
Split Wash/Rinse Arms	✓	✓
Rinse Aid Dispenser	✓	✓
Fully Automatic	✓	✓
Standard Drain Pump	✓	✓

# Kromo Hood-110-USA High-Temperature Dishwasher

# Kromo HD-130-USA Heavy Duty High-Temperature Dishwasher



Hood-110-USA (#49127)



HOOD-130-PREMIUM-USA (#49128)

Item	#49127	#49128
Model	HOOD-110-USA	HOOD-130-PREMIUM-USA
Rinsing Temperature (Set)	185 °F (85 °C)	185 °F (85 °C)
Tank Capacity	31.72 qt (30 L)	44.4 qt (42 L)
Tank Heating Element	2940 W	2700 W
Tank Temperature (Set)	160 °F (71 °C)	160 °F (71 °C)
Booster Capacity	10.64 qt (10 L)	15.84 qt (15 L)
Booster Heating Element	9800 W	9000 W
Inlet Water Pressure	25 - 95 PSI (170-620 kPa)	
Power	10.92 kW	10.75 kW
Electrical	220-240V / 60 Hz / 1 Ph	
Water Consumption / Cycle (water pressure 200kpa)	3.16 qt (3 L)	2.76 qt (2.61 L)
Washing Cycles	1(120)   2(180)	1(120)   2(180)   3(240)   4(300)   5(360)
Water Supply 131 °F Racks /H (*) (1)	30	30   20   15   12   10
Water Supply 50 °F Racks /H (*) (1)	30	20   20   15   12   10
Pump Power	1120 W (664 qt/628 L per minute***)	1750 W
Drain Pump	43 W hMAX 31.5" (800 mm) (43.12 qt / 40.8 L***)	
Rack Equipment	(2) Plastic Plates Basket (1) Large Mesh Glass Basket (2) Cutlery Basket	
Rack Dimensions	20" x 20"	
Crockery Dimensions	Plates: 16.25" (412 mm) dia. Tray Max: Gastronorm 1/1 (20.87" x 12.75")	Plates: 16.12" (409 mm) dia. Tray Max: Gastronorm 1/1 (20.87" x 12.75" /)
Net Weight	220 lb (100kg)	276 lb (125 kg)
Net Dimensions (WDH)	28.37" x 28.93" x 56.87" / 74" - Height (open hood)	

(\*) Standard Thermostop  
(†) In case of cold water supply and/or continuous washing, the rinse-water heating process might take more time than usual, until the proper rinse temperature is reached. For this reason, the wash-cycle total timing might result longer than set.

	Hood 110	HD 130
Double Skin Hood		✓
Wash Cycles	2	5
Wash and Rinse Temp Display		✓
Rinse Aid Dispenser	✓	✓
Split Wash/Rinse Arms	✓	✓
Deep Formed Tank		✓
Self Cleaning Vertical Pump		✓
Standard Drain Pump	✓	✓
Break Tank System for Backflow Prevention		✓
Standard Drain Pump	✓	✓
LCD Control Panel		✓
Language Selection/ Menu Personalization		✓
Self Diagnostic System		✓
PLUS System For Constant Temperature/Pressure	✓	
Corner Installation		✓



# Bar & Cafe Equipment

Granita Dispensers	09
Drink Dispensers	11
Drink Blenders	15
Coffee Grinders	19
Ice Crushers	21
Gelato Makers	25
Juice Bar Solutions	29

# 02

# ugolini®

---

Taste Never Stops.



# Ugolini **MT** Countertop Granita/Slushy Machine with Magnetic Drive

**ugolini**

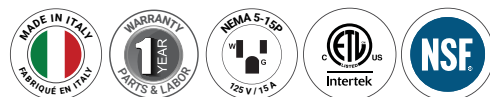

MT 1 (49081)



MT 2 (49082)



MT 3 (49083)

- Patented magnetic transmission mixing system
- Up to 3 crystal-clear, shock proof, food-grade polycarbonate bowls
- Uni-body stainless steel construction design
- Air-cooled condenser; Hermetic compressor
- Overload protector/Safety pressure switch condenser filter

	1 Bowl	2 Bowls	3 Bowls
Number of Bowls	1 Bowl	2 Bowls	3 Bowls
Item	49081	49082	49083
Model	MT 1P	MT 2	MT 3
Capacity (per bowl)	1 x 2.6 gal. (10L)	2 x 2.6 gal. (10L)	3 x 2.6 gal. (10L)
Exterior Material	Stainless Steel   Polycarbonate Container		
Power	460 W	1100 W	1300 W
Electrical	115V / 60Hz / 1Ph		
Refrigerant	R134a	R448a	R448a
Net Weight	57 lb (26 kg)	81.6 lb (37 kg)	108 (49 kg)
Net Dimensions (WDH)	11" x 18.5" x 26.4"	14" x 18.5" x 27.2"	21.3" x 18.5" x 27.2"

# Ugolini **GIANT** Multi-Functional Double Bowl Granita / Slush Machine with Magnetic Drive

**ugolini**

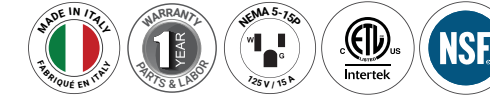

- Beverage machine designed for high volume sales.
- Dual crystal-clear for 100% product visibility, & Shockproof polycarbonate bowls
- Uni-body stainless steel construction design
- Air-cooled condenser; Hermetic compressor
- Overload protector/Safety pressure switch

Item	49080
Model	GIANT
Capacity (per bowl)	4 Gal. (15 L)
Number of Bowls	2
Exterior Material	Uni-body Stainless Steel   Shock Proof, Food-Grade Polycarbonate Container
Power	1600 W
Electrical	115V / 60Hz / 1Ph
Refrigerant	R448a
Net Weight	134 lb (61kg)
Net Dimensions (WDH)	18" x 20.9" x 3.2"

The Ugolini **GIANT** is the largest volume multifunctional dispenser specially designed to serve large quantities of product in a short period of time. With a total capacity of 30 liters and dual cooling circuit, it is designed for environments with high sales volumes. Designed, manufactured and assembled in Italy, **GIANT** stands tall and elegant and offers 100% product visibility, encouraging customers to buy with its dual crystal-clear, shockproof polycarbonate 15-liter bowls.

**GIANT** allows users to adjust product thickness by adjusting the available temperature control. Simply toggle the dial to choose from a wide range of consistency options from "Soft-Drink" to "Granita" and find the perfect icyness for your frozen beverage. Since **GIANT** is engineered to run 24/7, just set the control to stand-by mode when you're ready to shut down for the night, and switch it back to freeze when you open back up in the morning.



GIANT (49080)

# Ugolini Arctic Compact Countertop Juice Dispenser

**ugolini**

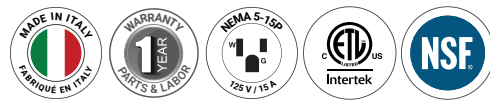

- One motor per unit
- Stainless steel uni-body construction
- Food-grade bowls and faucets
- Easily removable bowls
- Drink stirring by magnetic impeller
- Hermetically sealed compressor

Number of Bowls  
Item  
Model  
Capacity (per bowl)  
Exterior Material  
Power  
Electrical  
Refrigerant  
Net Weight  
Net Dimensions (WDH)

	2 Bowls	3 Bowls
Item	49085	49086
Model	ARCTIC COMPACT 8/2	ARCTIC COMPACT 8/3
Capacity (per bowl)	2 x 2 gal. (8 L)	3 x 2 gal. (8 L)
Exterior Material	Uni-body Stainless Steel   Shock Proof, Food-Grade Polycarbonate Container	
Power	270 W	315 W
Electrical	115V /60Hz / 1Ph	
Refrigerant	R134a	
Net Weight	37.5 lb (17 kg)	48.5 lb (22 kg)
Net Dimensions (WDH)	9.8" x 15.75" x 24.8"	14.6" x 15.75" x 24.8"



49085



49086

Simple, versatile and easy to use, these large volume dispenser is designed to cool all types of drinks - including any milk, pulpy fruit juice, coffee, tea and more - by way of its patented magnetic submerged pump and stainless steel gravity tap. Quick and easy to dismantle for perfect cleaning, it saves you time and makes your work easier.

One main difference between ARCTIC DELUXE and ARCTIC COMPACT models is that ARCTIC DELUXE is designed with one motor per bowl, while ARCTIC COMPACT has one motor which drives the impellers of all of its bowls through a belt, and at the same time acts as condenser fan.



49087

49088

49089

49090

# Ugolini Arctic Deluxe Impeller Juice Dispenser

**ugolini**

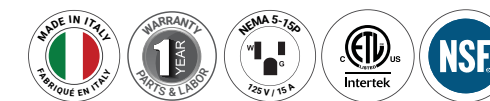

- Individual motors per bowl
- Up to 4 crystal-clear, shock proof, food-grade polycarbonate bowls
- Uni-body stainless steel construction design

- Air-cooled condenser; Hermetic compressor
- Overload protector/Safety pressure
- Switch Condenser filter

	1 Bowl	2 Bowls	3 Bowls	4 Bowls
Item	49087	49088	49089	49090
Model	ARCTIC DELUXE 20/1	ARCTIC DELUXE 20/2	ARCTIC DELUXE 20/3	ARCTIC DELUXE 20/4
Capacity (per bowl)	4 x 5.3 gal. (20 L)	1 x 5.3 gal. (20 L)	2 x 5.3 gal. (20 L)	3 x 5.3 gal. (20 L)
Exterior Material	Uni-body Stainless Steel Construction   Crystal Clear, Shockproof, Food Grade Polycarbonate Bowls			
Power	410	170	270	315
Electrical	115V / 60Hz / 1Ph			
Refrigerant	R134a			
Net Weight	64 lb (29 kg)	31 lb (14 kg)	37.5 lb (17 kg)	48.5 lb (22 kg)
Net Dimensions (WDH)	7" x 15.75" x 24.8"	9.8" x 15.75" x 24.8"	14.6" x 15.75" x 24.8"	19.7" x 15.75" x 24.8"



**SANTOS<sup>®</sup>**



Hand-made in Lyon.



# Santos # 54 Drink Mixer Milkshake Blender



Ideal for milk shakes, cappuccino cream, and smoothies.

This drink mixer is a long lasting equipment for professional users with:

- A speed variation from 8000 to 16000 RPM
- A heavy duty and silent motor
- Automatic motor activation with bowl detection

Includes:

- 2 bowls (0.675L/24fl oz) - 1 stainless steel bowl and 1 plastic bowl
- 3 removable agitators (by simple screwing/unscrewing on the spindle):
  - »1 universal spherical agitator for all beverages
  - »1 rubber agitator for creamy beverages
  - »1 winged deep agitator for frozen coffee

### 3 REMOVABLE AGITATORS



(1) Stainless steel bowl and  
(1) plastic bowl are included



Item	44634
Model	SANTOS 54
RPM	8,000 to 16,000 RPM
Power	230 W
Electrical	120V / 60Hz / 1Ph
Net Weight	12.7 lb (5.7 kg)
Net Dimensions (WDH)	7.5" x 7.5" x 20"



## Santos #62 Heavy Duty Blender

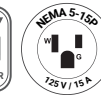

Blender for smoothies and iced drinks. You can make any kind of cocktail, smoothie, fruit juice, milkshake, granita and iced coffee frappe with the blender #62, thanks to its 30 pre-programmed recipes. Ideal appliance for juice bars, fast food and coffee shops.



- **PERFORMANCE** - Brushless motor: low consumption, high performance (8N.m)
- **SIMPLICITY** - Ease of use: Touch pad control panel with LCD display, and easy cleaning and maintenance: Removable sound enclosure, pad and jar
- **SILENCE** - New removable sound enclosure reduces the noise level significantly.



Easily fits onto a counter



Touch pad control panel



Stackable jars

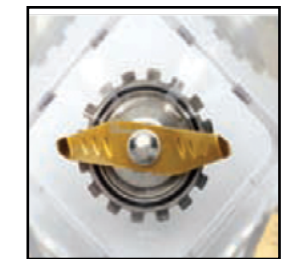

Tin coated blade

Item	39703
Model	SANTOS 62
Capacity	81 oz / 2.4 L
RPM	2500 - 15000
Power	1010 W
Amps	8A
Electrical	120V / 60Hz / 1Ph
Net Weight	21 lb / 9.4 kg)
Net Dimensions (WDH)	10" x 8" x 17"

## Santos #63 High Output Coffee Grinder 120 kg/hr (265 lb/hr)

SANTOS



Item	44636
Model	SANTOS 63
Production (Per Hour)	Up to 265 lb (120 kg)
Power	500 W
Electrical	120V / 60Hz / 1Ph
Net Weight	88 lb (40 kg)
Net Dimensions (WDH)	11" x 13" x 27"

### Silence, exceptional output Turkish coffee

The coffee shop grinder #63 is the ideal appliance for all stores which distribute large quantities of ground coffee: coffee shops, supermarkets and roasting establishments.

Fast, precise and reliable, it makes a quality grinding thanks to its precise setting and its Ø120mm grinding discs, designed and manufactured by Santos. Perfect for making Turkish coffee.

### Powerful exceptional performance

- Powerful asynchronous motor, very silent
- Extremely fast, the grinder #63 has a max output of 120kg/h
- Sturdy product, adapted to intensive use

### Precision and quality grinding

- Santos manufactures its own grinding discs to give you a perfect, constant and fine grinding (no burnt coffee effect)
- Equipped with triple cut grinding discs (Ø 120mm) that can be resharpened
- Very precise micro-metric setting of the grinding fineness
- Makes Turkish coffee: 36kg/h

### Comfort of use

- Accepts all kinds of bags: from 250g to 1kg
- Extremely silent for a great comfort of use
- Display of instructions on how to use the grinder, ideal for self-service use



## Santos #55 Silent Coffee/Espresso Grinder

SANTOS



### Powerful and reliable

- Powerful asynchronous motor for intensive use, very silent
- Sturdy product with aluminum body
- Very efficient and quick: one dose of coffee dispensed in less than a second

### Quality grinding

- Fresh ground coffee: no dispenser, coffee beans are ground on demand and dispensed directly into the filter holder
- Santos manufactures its own grinding discs to give you a perfect grinding, constant and fine

### Easy to use

- 3 tampers (Ø 53mm, Ø 55mm, Ø 57mm) are delivered with the product for all sizes of filter holders
- Fully automatic: the exact dose of coffee is dispensed automatically when the filter holder is detected
- Simply adjust the grinding and dosing, and visualize the number of doses distributed with the 5 digit counter.

Item	44637
Model	SANTOS 55
Output	55 lb/ hr (25 kg/ hr)
Power	800 W
Electrical	120V / 60Hz / 1Ph
Net Weight	33 lb (15 kg)
Net Dimensions (WDH)	8" x 16" x 23"



# Coffee Grinders

## Santos #09 Heavy Duty Countertop Ice Shaver



- Safety switch stopping the motor when the lever or the drawer is opened
- Stainless steel and sanitary cast aluminum antimicrobial paint
- Delivered with one adjustable disc to make shaved or crushed ice.
- Ergonomic and sturdy articulated lever
- New shockproof drawer without bysphenol
- Easy-to-clean base

Item	44023
Model	SANTOS 09
Production (Per Hour)	220 lb (100 kg)
Power	650 W
Amps	5.4 A
Electrical	100-120V/60Hz/1Ph
Net Weight	32 lb (14.7 kg)
Net Dimensions (WDH)	10" x 16.5" x 14"



## 2L Ice Shaver



- Producing ice pieces in various sizes, as well as the finely crushed ice for traditional Italian "granita"
- Pays very close attention to operator safety with the addition of a safety micro-switch on the feed throat and on the streamlined ice container
- Quality is guaranteed by the large sized throat in anodized aluminum, stainless steel small parts and components the structure in aluminum and steel

Item	17137
Model	IC-IT-0002
Bowl Capacity	2.11 qt (2 L)
Crushed Ice Max. Thickness	0.39" (10 mm)
Power	350 W / 0.3 hp
Electrical	110V / 60Hz / 1Ph
Net Weight	18.5 lb (8.4 kg)
Net Dimensions (WDH)	8.25" x 18.3" x 11.6"



## Santos #53 Ice Crusher



### Powerful, efficient and reliable

- Makes both fine and coarse crushed ice in just one touch of a button
- Exceptional output: Quickly makes 1.2 kg) of crushed ice in 30 seconds
- It is equipped with a heavy duty and quiet asynchronous motor
- It is adapted to intensive use and allows a hands free use thanks to its high capacity ice cube tank (1.2 kg)

### 2 functioning modes

- Button Hold: Manual function; Ice is crushed as long as the button is held.
- Button Press: Automatic function; Automatically crushes ice in container.

Item	39689
Model	SANTOS 53
Production (Per Hour)	330.7 lb (150 kg)
Power	130 W
Amps	1 A
Electrical	120V / 60Hz / 1Ph
Net Weight	22 lb (9.8 kg)
Net Dimensions (WDH)	8" x 12" x 19"



## 3L Ice Crusher

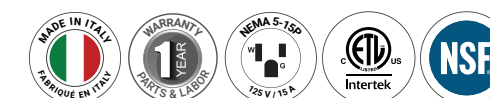

- Crushes any ice cubes made up to 40 x 40 mm at -3°C
- Adjustable lever for controlling ice thickness
- Great bar tool for preparing drinks, and restaurant for displaying fish or fresh foods

Item	47084
Model	IC-IT-0003
Capacity	3.17 qt (3 L)
Power	150 W
Electrical	110V / 60Hz / 1Ph
Net Weight	11.5 lb (5.2 kg)
Net Dimensions (WDH)	8.1" x 11.2" x 19.3"



Ice Shavers

Crushers

 Canada Only

**MUSSO** 

Da **50** anni le migliori  
The best for **50** years

**Gelato**  
**Makers**



# Musso Mini Gelato Maker 2L



Easy to use, Mini is the perfect ice cream maker to get professional results at home.

Small, with a large non-removable bowl, stainless steel spatula and a powerful, robust refrigeration system, the mini machine allows you to reach professional performance without pre-cooling.

Made of Stainless Steel, compact, and attractive, it has a modern design suitable for any room and kitchen.

Musso ice cream makers specialize in making dense, super high quality ice cream due to tiny ice crystals and low air content.

Musso mini is suitable for domestic or small scale commercial use. Also makes sorbet and frozen yogurt.

Item	58178
Model	MINI
Max Ingredients Capacity	0.75 L
Bowl Capacity	2 L
Material	Stainless Steel (Body)
Paddle Induction Motor	80 RPM
Mechanic Timer	60 min
Preparation Time	20 / 30 min
Power	200 W
Electrical	110V / 60Hz
Refrigerant	R134A
Net Weight	40 lb (18 kg)
Net Dimensions (WDH)	11.8" x 17.7" x 10.6"



- Strength**  
Made from AISI 304 Grade Stainless Steel.
- Stainless Steel**  
Sharp paddle breaks up lumps, preventing ice formation.
- No Electronics**  
No electronic components.

- Safe**  
Highest quality standards in product safety.
- Low Dispersion**  
Coils welded to bowl, minimized temperature dispersion.
- Perfect Speed**  
Perfect paddle speed (76 rpm) for air incorporation in gelato.



## Musso **Stella** Gelato Maker 3L



Elevate your dessert experience with the Musso 3L Italian Ice Cream Machine!

Designed for the true ice cream aficionado, this premium appliance allows you to create larger batches of gelato, sorbet, and ice cream with ease.

Crafted in Italy, it combines powerful performance with sleek, sophisticated design, making it a perfect centerpiece for your kitchen. Enjoy homemade delights in just 20-30 minutes and impress family and friends with your culinary creations.

With Musso, every scoop is a taste of Italy—unleash your creativity and indulge in the ultimate frozen treats!

Musso ice cream makers specialize in making dense, super high quality ice cream due to tiny ice crystals and low air content. Also makes sorbet and frozen yogurt.

Item	58179
Model	STELLA
Max Ingredients Capacity	1.5L
Bowl Capacity	3L
Material	Stainless Steel (Body)
Paddle Induction Motor	76 RPM
Mechanic Timer	60 min
Preparation Time	20 / 30 min
Power	250 W
Electrical	110V / 60Hz
Refrigerant	R134A
Net Weight	68 lb (31 kg)
Net Dimensions (WDH)	12.2" x 20.1" x 13.8"



### Strength

Made from AISI 304 Grade Stainless Steel.



### Stainless Steel

Sharp paddle breaks up lumps, preventing ice formation.



### No Electronics

No electronic components.



### Safe

Highest quality standards in product safety.



### Low Dispersion

Coils welded to bowl, minimized temperature dispersion.



### Perfect Speed

Perfect paddle speed (76 rpm) for air incorporation in gelato.

# Juice Bar Solutions



## Santos #10 Citrus Juice Extractor with Leveler

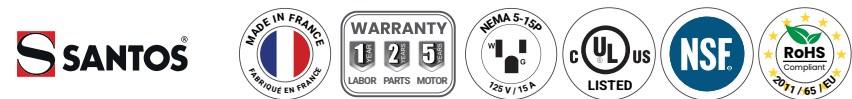

- Heavy duty and silent asynchronous motor
- Motor is equipped with an internal thermal detector and waterproof ON/OFF interlock switch
- Comes with a special clutch system that starts/stop when you press
- Stainless steel cone for limes, lemons and oranges

	Black	Silver
Color	Black	Silver
Item	39687	48111
Model	SANTOS 10	SANTOS 10C
Production (Per Hour)	31.70 qt (30 L)	
RPM	1800	
Power	0.35 hp / 260 W	
Amps	2 A	
Electrical	120V / 60Hz / 1Ph	
Net Weight	20.3 lb (9.2 kg)	
Net Dimensions (WDH)	12" x 8" x 15"	



## Santos #38 Citrus Juice Extractor



- Heavy duty and silent asynchronous motor
- Unbreakable sanitary polycarbonate bowl
- 3 Removable cones: 1 for lemons and oranges, 1 for grapefruits, 1 for limes
- Base in aluminum casting for added strength

Item	39688
Model	SANTOS 38
Production (Per Hour)	31.70 qt (30 L)
RPM	1800
Power	0.20 hp / 150 W
Amps	1.3 A
Electrical	120V / 60Hz / 1Ph
Net Weight	11 lb (5 kg)
Net Dimensions (WDH)	12" x 7" x 14"





48110

44025



39686

46268



**Stainless steel  
bowl**



39685

## Santos #11 Classic Citrus Juice Extractor



- Built to last, with a heavy duty and quiet asynchronous motor
- Wide spout accepting all types of glasses
- Base in aluminum casting for added strength
- Removable drip tray

	Chrome	Green
Color	Chrome	Green
Item	44025	48110
Model	SANTOS 11C	SANTOS 11G
Production (Per Hour)	31 qt (30 L)	
RPM	1800	
Power	0.2 hp / 155 W	
Amps	1.4 A	
Electrical	120V / 60Hz / 1Ph	
Net Weight	11 lb (5 kg)	
Net Dimensions (WDH)	9" x 12" x 14"	

## Santos #52 Citrus Juicer

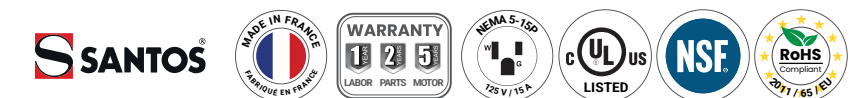

- Ideal for juice bars, health food stores, hotels, bars, restaurants, ice cream shops, institutions and hospitals
- 3 Removable cones included with Juicer
- Equipped with powerful and reliable commercial motor
- High output: extract up to 40L per hour (5 - 10 gallons)
- High Output, accepts jugs

	Black	Chrome
Color	Black	Chrome
Item	39686	46268
Model	SANTOS 52	SANTOS 52C
Production (Per Hour)	13 - 42.26 qt (20 - 40 L)	
RPM	1800	
Power	0.35 hp / 260 W	
Amps	2 A	
Electrical	120V / 60Hz / 1Ph	
Net Weight	21 lb (9.5 kg)	
Net Dimensions (WDH)	8" x 12" x 19"	

## Santos #70 Citrus Juicer



- Ideal product to make fresh juices from citrus fruits
- High output: 50 L per hour
- Perfect for intensive use
- Allows you to make citrus juice either in a glass or in a jug
- Cones for all types of citrus: lime, lemon, orange or grapefruit
- Auto start when with lever push (patented clutch system)
- Easy cleaning: removable stainless steel bowl, cone and cup
- Ideal for limes

Item	39685
Model	SANTOS 70
Production (Per Hour)	52.83 qt (50 L)
RPM	1800
Power	0.47 hp / 350 W
Amps	2.91 A
Electrical	120V / 60Hz / 1Ph
Net Weight	28.6 lb (13.5 kg)
Net Dimensions (WDH)	9.5" x 16" x 19"

## Santos #50 Fruit and Vegetable Juicer

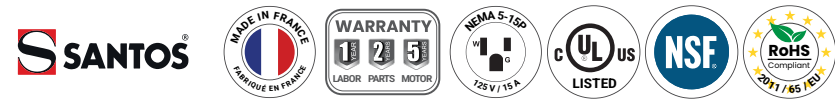

The Santos #50 is easy to use, silent and powerful, it is the ideal appliance for hotels, bars, restaurants, cafeterias, cocktail bars, institutions, hospitals, health food stores, juice bars and ice cream shops.

- Exclusive patents: exclusive extra wide feeding chute (79.5mm), EZY-clean™ system, instant friction braking system
- Professional motor, powerful and extremely silent
- High output juice extractor, adapted to intensive use
- Sturdy appliance mostly made of aluminum and stainless steel



Item	39494
Model	SANTOS 50
Production (Per Hour)	105.67 qt (100 L)
RPM	3600
Power	1 hp / 800 W
Amps	7 A
Electrical	120V / 60Hz / 1Ph
Net Weight	31 lb (14 kg)
Net Dimensions (WDH)	10" x 19" x 18"

## Santos #68 Fruit and Vegetable Juicer



The Santos 68 offers efficiency with innovative design. More powerful, more robust and easier to clean, this new generation juice extractor is dedicated to juice bars, health food stores, hotels, bars, restaurants, cafeterias, ice cream shops and institutions.

- Full stainless steel food-zone: no aluminum
- New generation patented EZY-Clean System II which saves you time (toolless removal of bowl, basket, and cover)
- Extremely sturdy: All metal shifter
- Wide feeding chute (79.5mm in diameter. Fits a whole apple)
- Exceptional output with up to 140 l/h, motor and baskets are calibrated, rotating at the ideal speed to extract a maximum juice
- Perfect filtration high quality, juice without any fruit pulp of the fruit, even for intensive use



Item	39684
Model	SANTOS 68
Production (Per Hour)	147 qt (140 L)
RPM	3600
Power	1.74 hp / 1,300 W
Amps	10.8 A
Electrical	120V / 60Hz / 1Ph
Net Weight	55 lb(25 kg)
Net Dimensions (WDH)	13" x 22" x 24"





## Santos #65 Cold Press Juicer

**SANTOS**



The cold press juicer Nutrisantos™ #65 is the solution to all juice bars, restaurants and shops wishing to make fresh cold pressed juices, on demand, in front of the customer.

This is a new way of juicing, pressing very slowly all kind of fruits, veggies, leafy greens, and preserving the vitamins, nutrients, enzymes, and minerals.

- Commercial cold press juicer: Aluminum body and stainless steel food zone. Equipped with a reliable induction motor. Heavy duty
- A new way of juicing: set your speed (5 to 80rpm) to get the juice you want.
- Fresh cold pressed juice made on-demand, in front of the customer. Cold pressed juice retains the maximum amount of nutrients, enzymes minerals and vitamins.
- XL chute: Wide chute Ø79.5mm to juice whole fruits and vegetables.
- No pre-cutting needed.
- Easy to clean: Removable pusher and juicing system for an easy cleaning (dishwasher safe).
- Exceptional yield: Maximum juice extraction.
- High spout: Accepts glasses, jugs, and blender jars. (21cm)



### Patented Juicing System

Exclusive cold press technology developed and patented by Santos

Item	45923
Model	SANTOS 65
Production (Per Hour)	Varies based on input
RPM	3600
Power	0.87 hp / 650 W
Amps	7 A
Electrical	120V / 60Hz / 1Ph
Net Weight	61.7 lb (28.6 kg)
Net Dimensions (WDH)	9.3" x 16.2" x 25.3" (236 x 412 x 642 mm.)

# zumoval

JUICERS FOR LIFE





Proven in the market for over 20 years, Zumoval juicers are the strongest on the market with heavy-duty motors and gears manufactured from stainless steel. It is also the fastest juicer on the market producing up to 20 L per hour of juice.

#### Great quality juice

The exclusive design of Zumoval citrus fruit squeezers means that the peel is not pressed during the squeezing process, but separated from the flesh. The result of this process is a high quality, tasteful and vitamin-rich juice.

#### Maximum performance at peak hours

Zumoval has also considered the various needs of different establishments, offering easy solutions to specific problems. Therefore, several different models have been designed, ranging from the Minimax, which squeezes 15 oranges per minute, to the FastTop which squeezes 45 oranges per minute, guaranteeing maximum efficiency at times of greater demand.

#### Strong and reliable

All our range includes high quality, durable materials, assembled under a strict manufacturing control. That is why we can state that our machines are able to run during long periods of time, without suffering any kind of mechanical damage. Due to their component design and their easy to dismantle squeezing system, they allow running express cleaning tasks.



Metal Gears



Optional Built-in Shower for Easy Cleaning



Self-Service Stainless Steel Tap

# zumoval

## JUICERS FOR LIFE



5 YEARS WARRANTY  
5 YEARS PARTS  
1 YEAR ON LABOUR



#### Self Tap / Push & Juice

A robust, easy-to-use, stainless steel self-service tap, especially designed to work in self-service mode in places of high consumption. Activated by a simple button press, stops juicing when released.

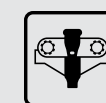

#### Automatic Filter

The automatic filter allows the automatic removal of pulp and seeds directly on the waste bins.



#### Juice Level Detection

System to have always a fixed amount of juice in the tank. When opening the tap, the machines automatically starts squeezing to fill the tank up to the level of the detector.



#### Self-Cleaning System (Automatic Shower)

This option provides a single or double flushing system which cleans quickly the juicing area, saving both time and labour cost.



#### 3.0 Digital Screen

This feature will inform you when the peel buckets are full of peels so that they can be emptied. Includes various functions such as waste bin indicator, fruit counter, tank capacity indicator

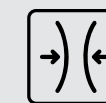

#### Squeezing Kit

Optional 45-60 mm kit that allows the squeezing of small citrus fruits such as small oranges, limes or mandarins. It is easily interchangeable by the user and allows the juicer to be much more versatile.

# Minimax

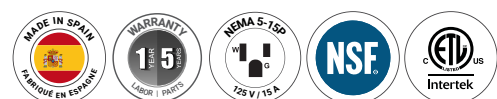

- The Minimax has on top a 6 kg stainless steel feeder basket. The feeding arm has a capacity of 6 pieces of citrus fruit.
- The front cover is made of tritan, a highly resistant and extremely durable material.

15 fruits per minute

13 lb (6 kg) basket capacity

2.56" - 3.15" / 65 - 80 mm squeezing dia.

20 lb (9 kg) Waste bin capacity



with Stainless Steel Self-Tap

	Compact Model	Compact Model With Self-Cleaning System
Item	39517	39518
Model	JE-ES-0015	JE-ES-0015-S
Production	15 fruits per minute	
Feeder Capacity	6 fruits	
Waste Bin	19.8 lb (9 kg)	
Fruit Diameter	2.56" - 3.15"	
Power	0.7 hp / 550 W	
Amps	9 / 8.6 A	
Electrical	115V / 60Hz / 1Ph	
Net Weight	113.5 lb (51.5 kg)	
Net Dimensions	13" (21.6" with chute) x 17.7" x 33"	
Optional Accessories	Stainless Steel Self-Tap	

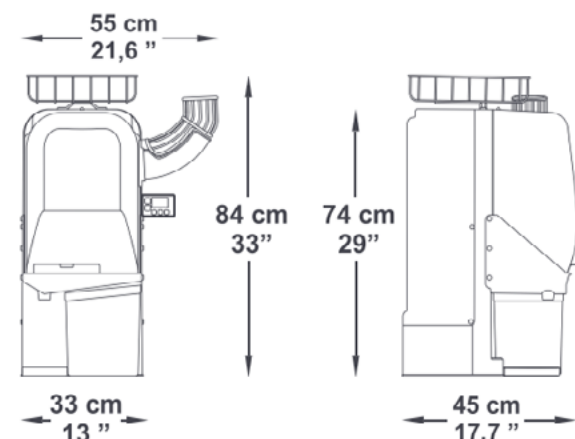

# Minimatic

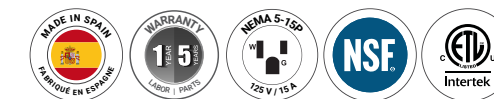

- With the built-in Stop-Fruit closure system, you can stop the flow of fruits from the feeder to proceed with the cleaning of the juicer.
- The front cover is made of tritan, a highly resistant and extremely durable material.
- Automatic feeding

15 fruits per minute

18 lb (8 kg) basket capacity

2.56" - 3.15" / 65 - 80 mm squeezing dia.

20 lb (9 kg) Waste bin capacity



With Stainless Steel Self-Tap

	With Self-Cleaning System	With Auto Feeder, Self-Cleaning Shower and Self Tap
Item	39519	39520
Model	JE-ES-0015-F	JE-ES-0015-T
Production	15 fruits per minute	
Feeder Capacity	13.2 lb (6 kg)	
Waste Bin	19.8 lb (9 kg)	
Fruit Diameter	2.56" - 3.15"	
Power	0.7 hp / 550 W	
Amps	9 / 8.6 A	
Electrical	115V / 60Hz / 1Ph	
Net Weight	117.5 lb (53.3 kg)	
Net Dimensions	13" x 17.7" x 36.6"	
Optional Accessories	Stainless Steel Self-Tap	(Already comes with Stainless Steel Self-Tap)

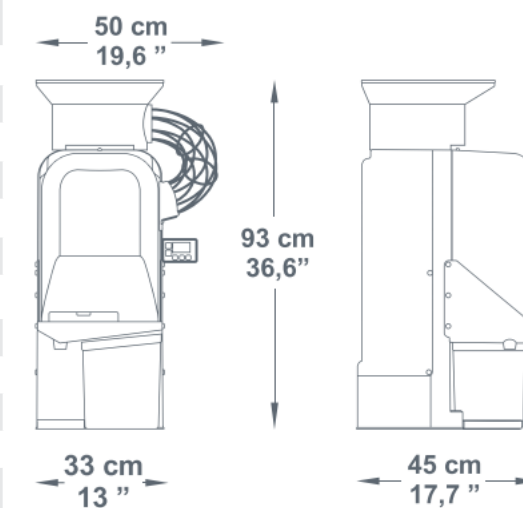

\* Net Dimensions does not include feed chute

# Big Basic Optional stand also available

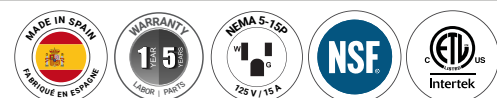

- 28 fruits per minute
- 18 lb (8 kg) basket capacity
- 3" - 3.5" / 75 - 90 mm squeezing dia.
- 26.5 lb (12 kg) waste bin capacity

- One piece, easy to clean cover
- Tritan protective screen



47960



48009

Specially designed for large fruit, such as grapefruits and pomegranates

	With Self-Cleaning System	With Self-Cleaning System, Push and Juice Button
Item	47960	48009
Model	JE-ES-0028N-BB	JE-ES-0028P-BB
Production	28 fruits per minute	
Feeder Capacity	17.6 lb (8 kg)	
Fruit Diameter	3" - 3.5"	
Peel Bucket	26.5 lb (12 kg)	
Power	0.75 hp / 560 W	
Amps	4.1 / 3.7 A - 9 / 8.6 A	
Electrical	115V / 60Hz / 1Ph	
Net Weight	110.9 lb (50.3 kg)	
Net Dimensions	24.4" x 20.5" x 22.4"	
Optional Accessories	-	Auto Filter

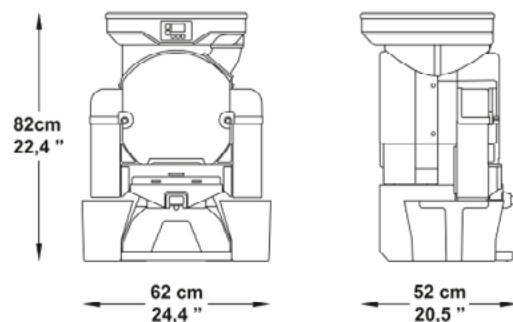

# Top

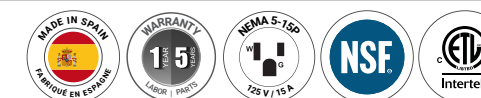

- 28 fruits per minute
- 55 lb (25 kg) basket capacity
- 2.5" - 3.15" / 65 - 80 mm squeezing dia.
- 26.45 lb (12 kg) waste bin capacity

- One piece, easy to clean cover
- Tritan protective screen

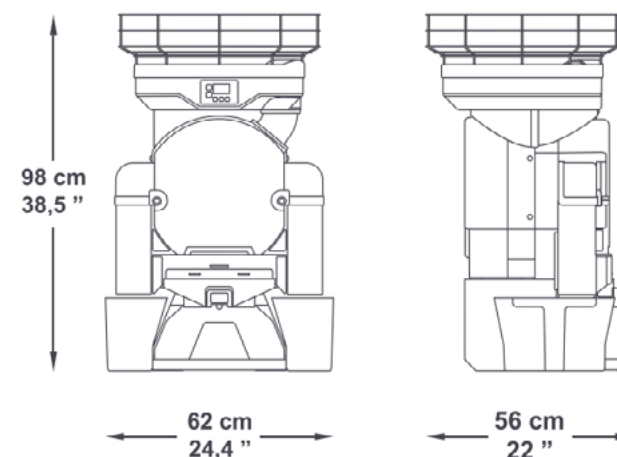

47989

	With Auto Feeder, Self-Cleaning System, Push and Juice Button
Item	47989
Model	JE-ES-0028N-F
Production	28 fruits per minute
Feeder Capacity	39 lb (18 kg)
Fruit Diameter	2.56" - 3.15"
Peel Bucket	44 lb (20 kg)
Power	0.75 hp / 560 W
Amps	9 / 8.6 A
Electrical	115V / 60Hz / 1Ph
Net Weight	105 lb (47.5 kg)
Net Dimensions	24.4" x 22" x 38.5"
Optional Accessories	Auto Filter

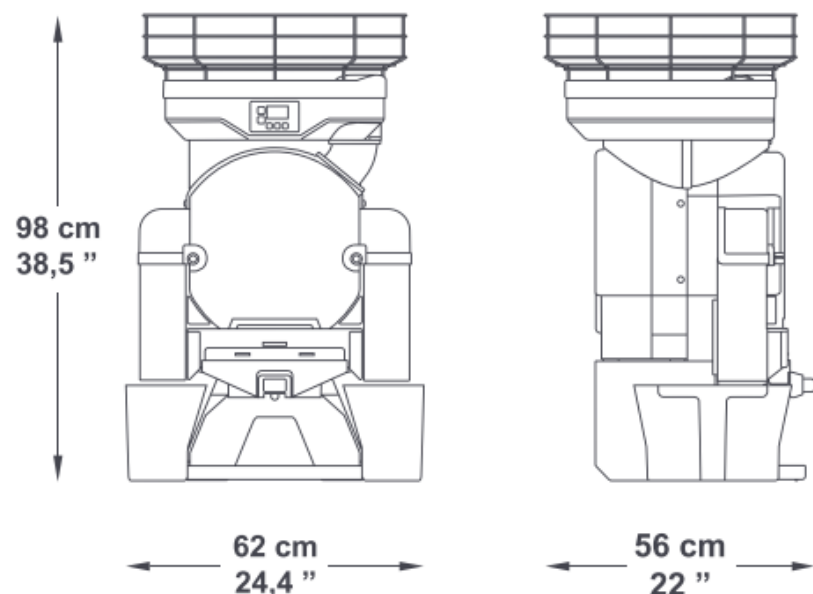

47990

Optional stand also available **FastTop**



45 fruits per minute



55 lb (25 kg) basket capacity



2.5" - 3.15" / 65 - 80 mm squeezing dia.



26.7 lb (12 kg) waste bin capacity



40531

Item  
Model  
Production  
Feeder Capacity  
Fruit Diameter  
Peel Bucket  
Power  
Amps  
Electrical  
Weight  
Dimensions  
Optional Accessories

Auto Feeder, Self-Cleaning System and Juice Level Detector	With Auto Feeder, Self-Cleaning System, Push and Juice Button
40531	47990
JE-ES-0045	JE-ES-0045N-B
45-50 fruits per minute	
39 lb (18 kg)	
2.56" - 3.15"	
26.5 lb (12 kg)	
0.75 hp / 560 W	
9 / 8.6 A	
115V / 60Hz / 1Ph	
113.5 lb (51.5 kg)	
19.7" x 24.4" x 38.2"	
-	Auto Filter

# Options and Accessories

Convenient dispenser stands perfect for customer self-service. Fantastic for buffets, hotel breakfast, luxury lounges. The stands also contain a large waste bin for 50 kg of waste content, or roughly 300 spent oranges.

Dispenser stand contains a large tank, allowing immediate dispensing of stored juice, great for volume service.

Self service stand does not contain a tank, and juice is squeezed fresh on demand. Perfect for an interactive customer experience that draws attention and interest.

Item	Description	Compatible Items
45790	<b>Self-Service Stand</b> - Compatible with <b>BigBasic, Top, and FastTop</b> models equipped with Self Tap, or Push & Juice Button	48009, 47989, 47990
40539	<b>Dispenser Stand</b> - Compatible with <b>BigBasic, Top, and FastTop</b> models without Self Tap, or with Push & Juice button	47960, 48009, 39522, 47989, 40531, 47990
45636	<b>Squeezing Kit</b> - For smaller citrus - 1.77"-2.36"	All BigBasic, Top and FastTop models



Squeezing Kit



Dispenser Stand



Self-Service Stand

# Cooking Equipment

Kebab Broilers	51
Dome Ovens	55
Tunnel Ovens	70
Deck Ovens	73
Panini Grills	77
Pasta Cookers	81
Patty Making	85

# 03





# POTIS



## Exceptional Performance and Genuine Flavors for Your Doner Kebabs.

This gyro grill features top-notch attributes and precise control, making it easy to prepare delectable doner kebabs.



# Potis Döner Kebab Broilers

## Natural Gas

Regulator Sold Separately

49060 only 49060 Excepted



- Stainless steel structure
- The distance between the cooking spit and burners can be adjusted
- Continuous pilot for instant ignition of the main burner
- Stainless steel octangular grease tray
- Designed for high performance and consistent results
- Heavy duty motor
- MU Series Motor position is convertible to rear mount- kit sold separately

Item	40 kg, 3 Burners		70 kg, 4 Burners	120 kg, 5 Burners
	49060	49160	49161	49162
Model	NA-GD3	NA-GD3/MU	NA-GD4/MU	NA-GD5/MU
Gas Type	Natural Gas (NG)		Natural Gas (NG)	Natural Gas (NG)
Cooking Capacity	88.18 lbs. (40 kg)		154.3 lbs. (70 kg)	264.5 (120 kg)
Max Height of Meat	17.7" (450 mm)		24.8" (630 mm)	31.8" (810 mm)
Material	Stainless Steel		Stainless Steel	Stainless Steel
BTU (per hour)	28,500		38,000	47,500
Burner Surface Area (HxW)	19.1" x 7.3"		25.3" x 7.2"	31.8" x 7.2"
Floor Space (without grease tray, WxD)	20" x 23.2"		20" x 23.2"	26" x 23.6"
Floor Space (with grease tray, WxD)	20.6" x 26.7"		21.6" x 29"	26.3" x 29.5"
Net Weight	53 lb (24 kg)		59.5 lbs. (27 kg)	94.8 lbs. (43 kg)
Net Dimensions (WDH)	20.7" x 26.8" x 36.2"		40.9" x 39" x 28.6"	55.1" x 61.4" x 37.4"
Conversion Kits (MU only)	49130		49145	49146
Optional Heat Shield (1) L/R	49132		49129	Included
Additional Skewers	49070		49069	49068

## Potis Parts & Accessories:

- 49076- Heavy Duty Skewer Stand
- 49075- Magnet Coil
- 49074- Thermocouple 330mm
- 49073- Motor Drive 1RPM
- 49072- Combustion Grating for Dual Burner
- 49071- Dual Burner with Nozzle/Natural Gas for GD3/4/5
- 49067- Dish (150 mm Diameter)
- 49066- Dish (195 mm Diameter)
- 49065- Dish (250 mm Diameter)
- 49131- Shovel Large Size ( 300 mm / 11.8")

## Electric

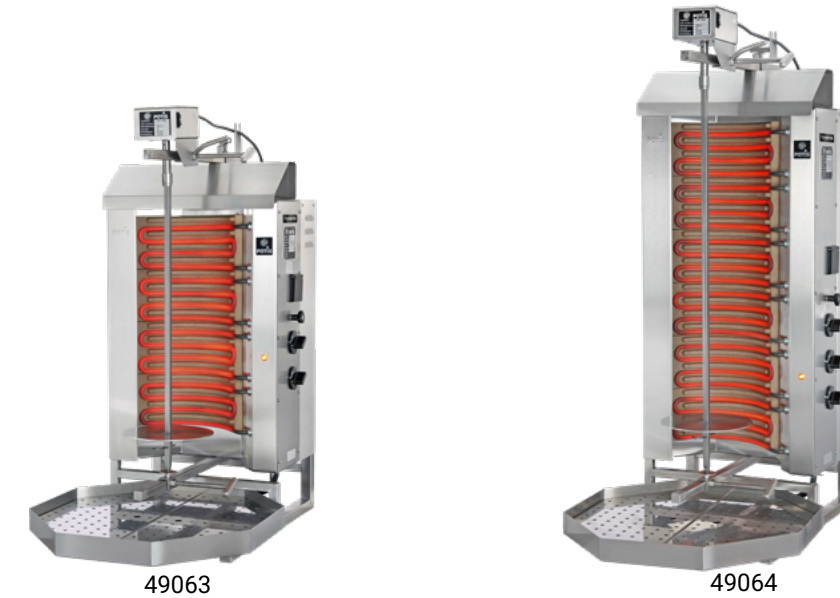

- Stainless steel structure
- Individually controlled infrared burners with ceramic plates
- Cooking Capacity
- The distance between the cooking spit and burners can be adjusted
- Stainless steel octangular grease tray
- Designed for high performance and consistent results
- Heavy duty motor

Item	30 kg, 2 Burners	50 kg, 3 Burners
	49063	49064
Model	NA-E2	NA-E3
Cooking Capacity	66.13 lbs. (30 kg)	110.23 lbs. (50 kg)
Max Height of Meat	18.1" (460 mm)	27.6" (700 mm)
Material	Stainless Steel	
Reflector Surfaces	4 ceramic bricks	6 ceramic bricks
Power	6,000 W	9,000 W
Electrical	208V / 60Hz / 1Ph + N	208V /60Hz / 3Ph + N
Floor Space (without grease tray, WxD)	17.7"	19.7"
Floor Space (with grease tray, WxD)	19.68" x 25.59"	19.68" x 25.59"
Net Weight	63.4 lbs. (29 kg)	79.3 lbs. (36 kg)
Net Dimensions (WDH)	17.7" x 19.7" x 36.2"	17.7" x 19.7" x 44"
Additional Skewers	49070	49069



## Quality Without Compromise

A long tradition made of passion, competence and innovation is the basis of the proposal of professional pizza ovens: different models and types to meet all the needs of an increasingly stratified clientele. The rigid production standards give birth to high-performance pizzeria ovens with refractory floors capable of evenly distributing heat and guaranteeing excellent performance.

Valoriani ovens are available with wood, gas or electric power to allow pizza makers to adapt to different types of cooking and preparation. An elegant and functional design, the possibility of customizing the dome using mosaic or fiberglass, clean and modern lines that integrate well into any environment. Valoriani professional ovens are dedicated to both small pizzerias and large chains, the common factor is absolute quality, without compromises.

 **Canada Only**



## Baby Series Wood & Gas Dome Oven

See Accessories on pg.69



48142



48137



48144/48143

### Small oven, big performance

The Tuscany made Baby series of wood/gas-fired ovens combines traditional refractory stone cooking with a sleek, modern dome. Practical to move, easy to install and use the quality of Valoriani refractory materials at the level of professional cooking directly at your home, or for professional cooking on the go for small events.

The Baby oven can be powered by wood or gas, guarantees uniform pizza cooking and despite its small size, is capable of great performance. Baby ovens require little maintenance and offer great satisfaction, and the prestige of the Valoriani brand at the side of all your special occasions.

- Outside dome finished with high-gloss or aesthetically pleasing painted mosaic and stainless steel arch.
- No extra finishing required.
- Optional full stand.
- Internal dome is created from refractory materials of professional quality.
- Bakery floor made of refractory Cotto clay stone.

	Baby 60 Red Metal	Baby 75 Red Metal	Baby 75 Black Metal	Baby 75 Mosaic
Item	48144	48143	48142	48137
Model	BABY-60-RED-METL	BABY-75-RED-METL	BABY-75-BLACK-METL	BABY-75-MIX-BLK
Gas Type	NG/LP			
Pizza Capacity (dia 11"-12")	1	2	2	2
Color/Material	Red Metal	Red Metal	Black Metal	Mix Black Mosaic
BTU ( max per hour)	44,358	44,358	44,358	44,358
LPG Gas Working (Kcal max)	11,177	11,177	11,177	11,177
BTU (Power in working order)	31,051	35,486	35,486	35,486
Kcal (Power in working order)	7,824	8,942	8,942	8,942
Flue Diameter	6"	6"	6"	6"
Arch Opening (WxH)	14" x 8"	14" x 8"	14" x 8"	14" x 8"
MIN area required with or without base (WxD)	34.25" x 34.25"	39" x 39"	39" x 39"	39" x 39"
Interior Dimensions (WxD)	23.6" x 13"	29.5" x 13"	29.5" x 13"	29.5" x 13"
Net Weight	326.3 lb (148 kg)	485 lb (220 kg)	485 lb (220 kg)	485 lb (220 kg)
Net Dimensions (WDH)	32" x 30" x 24"	39.8" x 39.4" x 25.2"	39.8" x 39.4" x 25.2"	39.8" x 39.4" x 25.2"
Included	Full Stand, Tube, Rain Cap, Shelf	Half Stand, Tube, Rain Cap, Shelf	Half Stand Tube, Rain Cap, Shelf	Half Stand Tube, Rain Cap, Shelf

Mosaic Option: 48209

Full Stand for 75 : 48709

Full Stand for 65 : 48708

# Igloo Series Wood & Gas Dome Ovens

See Accessories on pg.69



Fully Customizable



	Igloo 100	Igloo 120	Igloo 140	Igloo 160	Igloo 180
Item	48203	48204	48205	48206	48207
Model	IGLOO-100	IGLOO-120	IGLOO-140	IGLOO-160	IGLOO-180
Pizza Capacity (dia 11"-12")	4	5-6	8-9	14-15	17-19
Color/Material	Customizable (Mosaics finish ordered separately: 48209)				
BTU (max per hour)	85,304	98,952	116,012	116,012	116,012
Power	300 W				
Amps	1 A				
Electrical	110-120 Vac / 60 Hz / 1Ph				
Flue Diameter	8" (200mm)				
Arch Opening (WxH)	21" x 11" (540 x 280 mm)				
Interior Dimensions (WxD)	39" x 39"	47" x 47"	55" x 55"	63" x 63"	71" x 71"
Net Weight	2200 lb (1000 kg)	3087 lb (1400 kg)	3527 lb (1600 kg)	4188 lb (1900 kg)	4850 lb (2200 kg)
Net Dimensions (WDH)	54.5" x 57.8" x 41"	61.8" x 65.9" x 41"	70.7" x 74.1" x 41"	78.7" x 83.8" x 41"	88.3" x 95.2" x 41"
Optional Accessories*	48208 - Metal Stand Support	48278 - Metal Stand Support	48279 - Metal Stand Support	48280 - Metal Stand Support	48281 - Metal Stand Support

\*Ovens accept all gas types, after necessary adjustments following manual.

# The First Professional Breathable Pizza Oven

Thanks to passion, research, and over one hundred years of experience in producing refractories, Valoriani has created the igloo oven, the first and only breathable professional pizza oven capable of discharging cooking humidity to the outside and keeping the heat produced by combustion.



## Customization Samples



## Customizable Elements

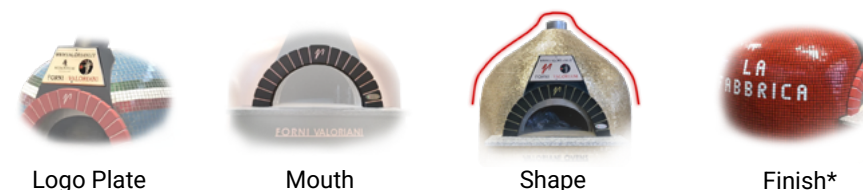

Logo Plate

Mouth

Shape

Finish\*

### Full Customization List:

- Arch Color Change
- Steel Arch
- Black and/or Larger Shelf or with Grid
- Logo Plate
- Central Smoke Outlet
- Volcano Shape
- Neapolitan Style as Verace
- Rectangular Mouth
- Dome Cover color/Mosaic
- Fiberglass Dome (120 size only)

\*Mosaic finishes at additional charge, selection on next page.

- Choice of Pre-Cast Modular or pre-assembled pizza ovens.
- Presents a spectacular cooking display, adding ambiance.
- Low maintenance cooking.
- Cost-effective operation with a choice of wood-only, gas only or gas/wood combination.
- Fast cooking times – a pizza will cook perfectly in 2-3 minutes, or as short as 60 seconds for Neapolitan pizzas.
- Ability to cook an array of different foods - from pizzas to your complete menu.
- Enhanced flavors- your customers will love the versatility - ability to use different cooking methods; baking, braising, stewing, sautéing, grilling, smoking, roasting, searing in juices, maintaining moisture & flavor, preventing food from drying.
- Extremely durable and – built to last.



## Pre-Assembled (Includes stand and mosaic)

	Igloo 100 Black Mosaic and Black Brick	Igloo 120 Red Iridium Mosaic and Black Brick
Item	48126	48127
Model	IGLOO-100-MIX-BLACK	IGLOO-120-RED-IRIDIUM
Color/Material	Black Mosaic and Black Brick	Red Iridium Mosaic and Black Brick

# Rotativo Wood & Gas Dome Ovens

See Accessories on pg.69



- Choice of Pre-Cast Modular or pre-assembled pizza ovens.
- Presents a spectacular cooking display, adding ambiance.
- Low maintenance cooking.
- Cost-effective operation with a choice of wood-only, gas only or gas/wood combination.
- Fast cooking times – a pizza will cook perfectly in 2-3 minutes, or as short as 60 seconds for Neapolitan pizzas.
- Ability to cook an array of different foods - from pizzas to your complete menu.
- Rotating cooking surface
- Extremely durable and – built to last.



Refer to previous page for options.

Mosaic (48209) choices:

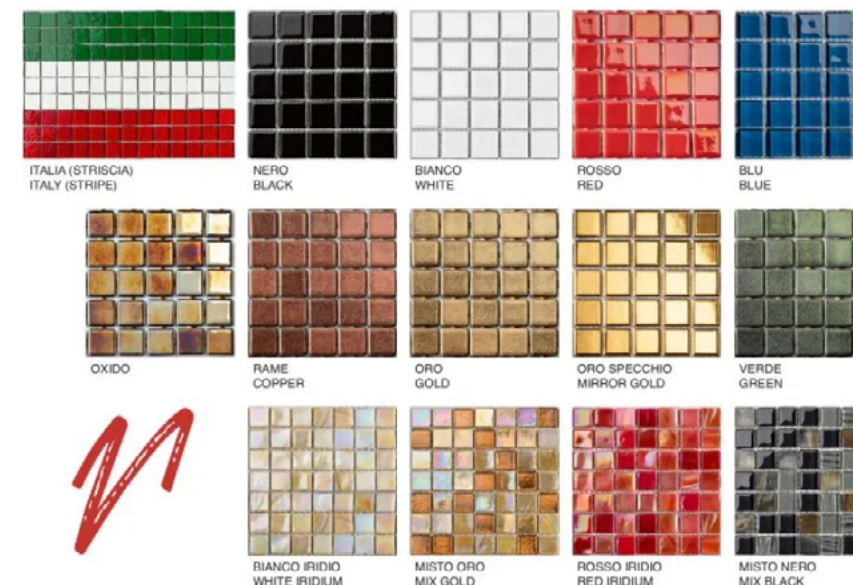

	Rotativo 120
Item	48145
Model	ROTATIVO120-RB
Pizza Capacity (dia 11"-12")	8-9
Color/Material	Red Brown Mosaic & Black Brick
BTU (max per hour)	98,952
Power	90 W Burner, 200 W Rotation
Amps	1 Amp Burner, 2 Amp Rotation
Electrical	110-120 Vac / 60 Hz / 1Ph
Flue Diameter	8" (200mm)
Arch Opening (WxH)	22" x 11.5" (540 x 280 mm)
Interior Dimensions (WxD)	55" x 55"
Rotating Floor	47" x 47" (1200 x 1200 mm)
Net Weight	3637.6 lb (1650 kg)
Net Dimensions (WDH)	70.9" x 79.8" x 42.3" (1800 x 2028 x 1074 mm)



\*Ovens accept all gas types, after necessary adjustments following manual.

# ALFA

Modern • Professional • Efficient



Only available in the U.S.A



# Quick Series Gas/ Wood Hybrid Ovens

See Accessories on pg.69



**Wood**  
High-quality materials and construction technology make Alfa professional wood-burning ovens highly efficient with very fast lighting and preheating times along with low wood consumption.

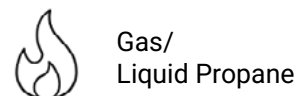

**Gas/ Liquid Propane**  
Latest generation burners and patented Alfa technology allow gas-powered models to quickly generate heat and keep it constant with maximum precision and efficiency.



**Hybrid**  
Thanks to the practical Hybrid Kit developed by the Alfa R&D team, the gas oven can be transformed into a wood-burning oven, allowing to decide from time to time which fuel to use according to the needs of the moment.

Dome Ovens

COOKING EQUIPMENT

03

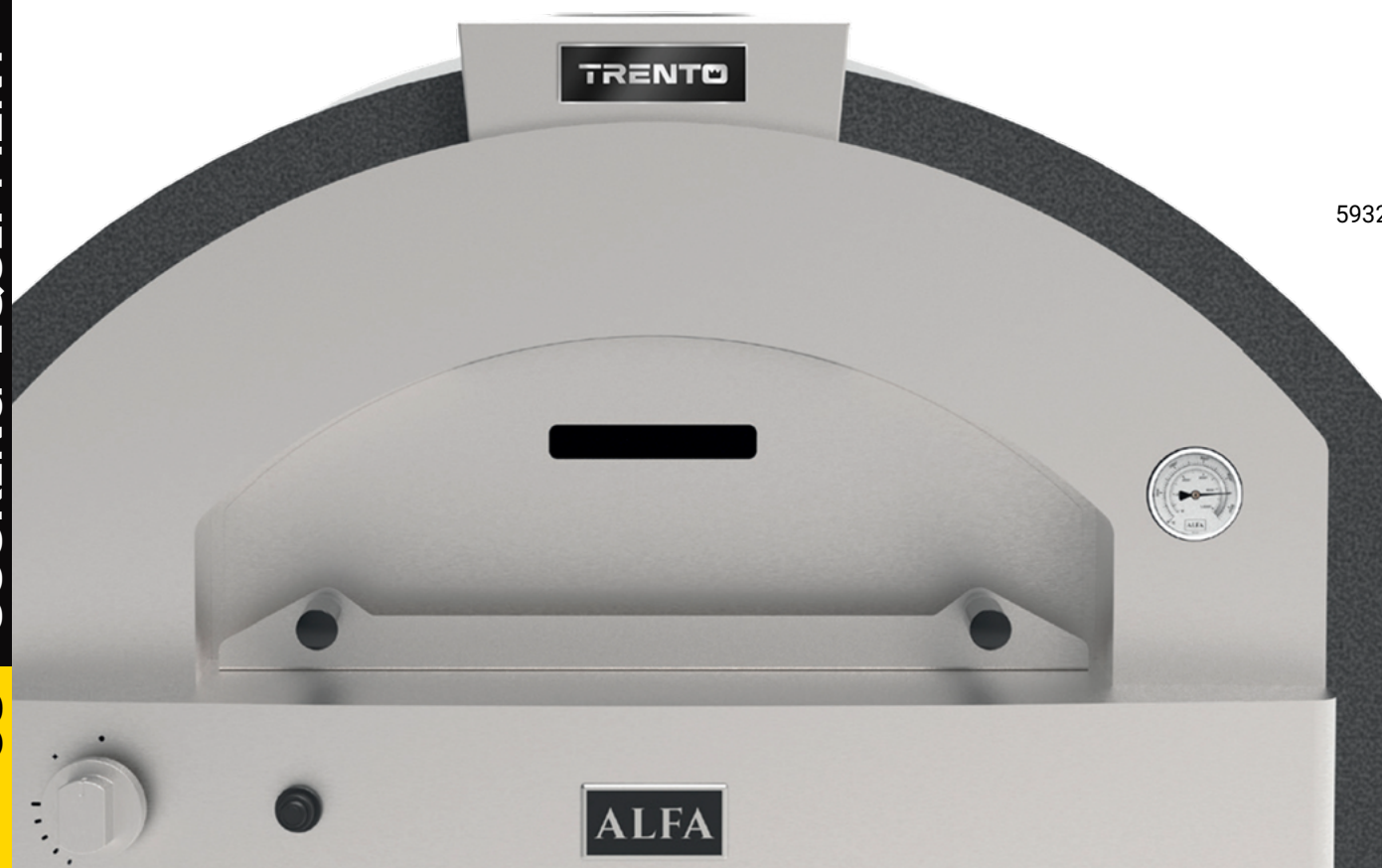

59321



59330

Dome Ovens

COOKING EQUIPMENT

03

	Quick Series - 2 Pizzas (Without stand)	Quick Series - 4 Pizza (Without stand)	Quick Series - 6 Pizza (With stand)
Item	59321	59322	59330
Model	FP-Q2P-TM-GRI-U	FP-Q4P-TM-GRI-U	FP-Q6P-BM-GRI-U
Gas Type	Natural Gas (NG) / Liquid Propane (LP)		
Pizza Capacity	2	4	6
Pizza Production (per hour)	40	50	70
BTU (per hour)	81,891	102,364	116,012.82
Heat Capacity	24 kW	30kW	34 kW
Heating Time (to reach 500°C / 932°F)	40 minutes	50 minutes	70 minutes
Cooking Floor	31.5" x 27.5"	35.4" x 35.4"	47.25" x 43.3"
Net Weight	421 lb (191 kg)	555.6 lb (252 kg)	1210.3 lb (549 kg)
Net Dimensions (WDH)	40.9" x 39" x 28.6"	46.9" x 48.4" x 31.5"	55.1" x 61.4" x 37.4"

	Zeno Series - 4 Pizzas	Zeno Series - 6 Pizzas
Item	59331	59328
Model	FP-Z4P-TE-NER-U	FP-Z6P-BE-NER-U
Pizza Capacity	4	6
BTU (per hour)	46000	62000
Pizza Production (per hour)	60	80
Max Power	13.5 kW	18 kW
Max Current	32.5 A	43.5 A
Electrical	240V / 60Hz / 3Ph	
Heating Time (to reach 500°C / 932°F)	75 minutes	120 minutes
Cooking Floor	29.5" x 29.5"	29.5" x 44.3"
Net Weight	672 lb (305 kg)	1058 lb (480 kg)
Net Dimensions (WDH)	40.9" x 45.7" x 33.5"	40.9" x 60.4" x 68.9"
Oven Stand	59329	59338

59331



## Zeno Series Electric Ovens

See Accessories on pg.69



- **Ready to Use:** No masonry work needed; immediately ready to use
- **Touch Screen Control:** User-friendly interface for managing oven and heat settings.
- **Independent Modulation:** Separate controls for ceiling and floor heat for optimal cooking.
- **Fumes Collection:** Efficient ducting system for safe and clean fume exit.
- **Energy-Efficient:** Advanced design and triple insulation ensure energy savings while maintaining high performance.
- **Built-In Installation:** Designed for built-in use with required maintenance space.



59328 + 59338

## Accessories

Alfa Accessories

NEW!

ALFA



Item	Description
59336	Butterfly valve for Quick Series 2 Gas
59337	Butterfly valve for Quick Series 4 & 6 Gas and 2 Wood
59334	Chimney cap for Quick Series 2 Gas
59335	Chimney cap for Quick Series 4 & 6 and 2 Wood
59332	Chimney flue for Quick Series 2 Gas
59333	Chimney flue for Quick Series 4 & 6 Gas and 2 Wood
59323	Kit hybrid for Quick Series 2
59324	Kit hybrid for Quick Series 4
59325	Kit hybrid for Quick Series 6
59326	Black Stand for Quick Series 2
59327	Black Stand for Quick Series 4
59329	Black Stand for Zeno Series 4
59338	Black Stand for Zeno Series 6



Stand (Black)



Butterfly Valve



Chimney Cap



Chimney Flue



Kit Hybrid

Valoriani Accessories

NEW!



Item	Description
48399	Flame Separator for Baby Ovens
48400	Flame Separator for Igloo and OT Ovens
48402	Metal Cap for Burner for Baby Ovens
48460	Pizza Stone 33 x 33 cm Octagonal
48461	Pinsa Pizza Stone 35 x 40 cm Rectangular
48462	Metal Support for Octagonal Pizza Stone #48460
48463	Pizza Shovels (2 pc) and Brush (1 pc) 3 pcs Per Set
48465	Metal Cap for Igloo and OT Ovens
48466	Mouth Reduction for Igloo and OT Ovens H= 33 cm
48467	Tuscan Grill with Support, Big Size 38.5 x 33.2 cm
48468	Tuscan Grill with Support, Small Size 25.4 x 25.4 cm
48470	Fire Guard for Baby Ovens

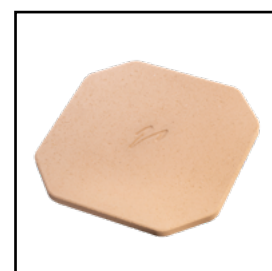

Pizza Stone Octagonal



Fire Guard for Baby Ovens



Fire Separator for Baby Ovens

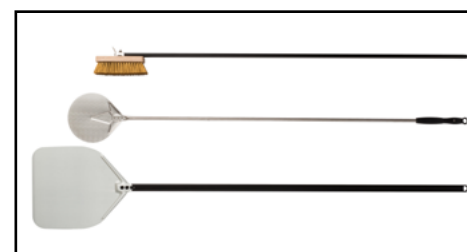

Pizza Shovels and Brush set

# Tunnel Oven

**Consistent and Even Baking:** Tunnel ovens provide consistent heat distribution, which ensures uniform baking across all products. This is crucial for maintaining product quality, as variations in temperature can lead to inconsistent results. The continuous belt system allows for even cooking, reducing the risk of overcooking or undercooking.

**High Production Capacity:** Tunnel ovens are designed for high-volume operations, making them ideal for businesses with large production needs. They can handle a continuous flow of baked goods, improving efficiency and throughput, which is essential for meeting customer demands in a busy bakery.

**Energy Efficiency:** Modern tunnel ovens are designed to be energy-efficient, using less fuel and reducing waste. They often have insulation and advanced heat recovery systems that help reduce operating costs. This can result in significant savings over time, especially for high-volume bakeries.

**Automation and Labor Savings:** The automated nature of tunnel ovens means that once the products are placed on the conveyor belt, the oven does the rest. This reduces the need for manual intervention and allows your staff to focus on other tasks. It helps in minimizing labor costs and improving overall workflow efficiency.

**Space Efficiency:** Tunnel ovens are often compact and can be designed to fit within the available space in your bakery. Their continuous belt system allows for more efficient use of space compared to traditional batch ovens, which require more floor area for loading and unloading. Trento tunnel ovens are also stackable to a maximum of three units with the same footprint.

## 63" Electric Conveyor Pizza Oven, 20" Wide Belt

Stand sold separately



The Trento Ventilated Tunnel Oven is a perfect addition for any kitchen that requires efficient and consistent baked goods. This unit has been redesigned with new and modern features. The ventilated chamber provides consistent and uniform baking of foods by providing necessary air circulation.

Convenient display panel on the unit provides the freedom to adjust the temperatures, speed, and direction of the conveyor belt. This oven is designed to be durable and allows stacking up to three ovens at a time.

- Consistent baked products with high efficiency
- Ventilated chamber provides consistent and uniform baking of foods by providing necessary air circulation
- Convenient display allows constant monitoring and adjustments
- Innovative digital touch panel
- Conveyor belt with dual direction
- Adjustable settings
- Equipped with a safety thermostat
- Stackable design (up to three units)

Item	46725
Model	CE-IT-0500
Output Per Hour	40 / with 13" (330.2 mm) dia.
Power	14.2kW
Amps	39 A
Electrical	230V / 60Hz / 3Ph
Net Weight	343.9 lb (156 kg)
Net Dimensions (WDH)	46" x 66.9" x 19.7"
Optional Item(s)	Item 47702: Stainless Steel Stand with Wheels

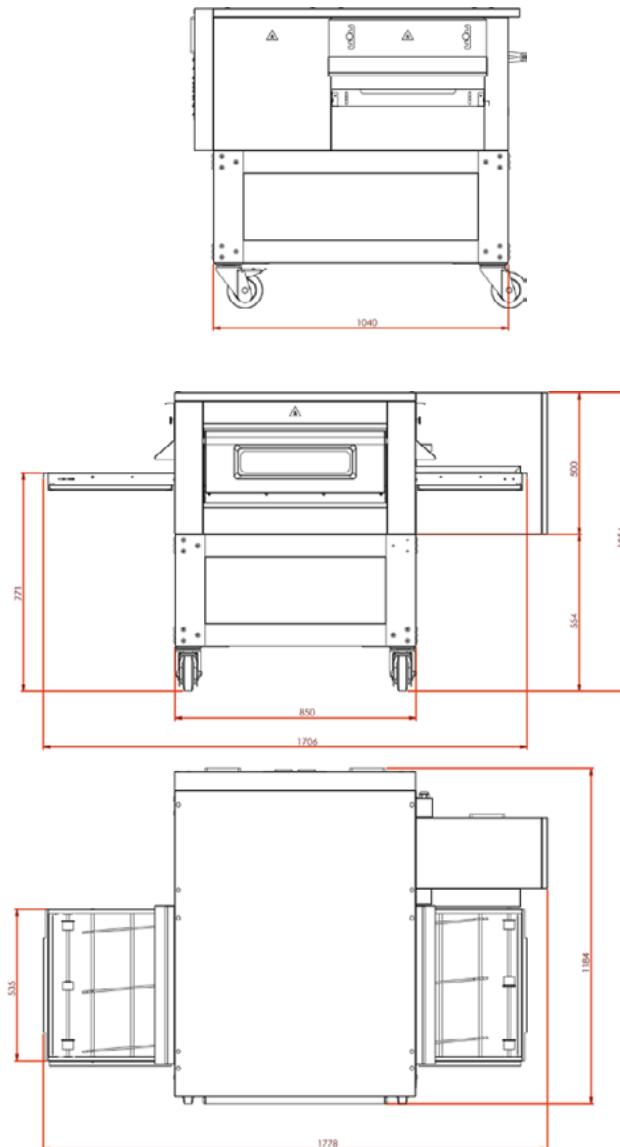

Display Panel

# Deck Ovens

## Fuoco Series Pizza Oven



### 28" x 28" Chambers



40637

40638

	Single Chamber	Double Chamber
Item	40637	40638
Model	PE-IT-0024-S	PE-IT-0048-D
Capacity (ea. chamber)	Four 12" or 13" pizzas / One 18" pizza or One 24" x 16" pizza	Four 12" or 13" pizzas / One 18" pizza or One 24" x 16" pizza
Maximum Temperature	450°C (842°F)	
Power	6, 600 W	13, 200 W
Electrical	230V / 60Hz / 3Ph	
Chamber Dimensions	27.6" x 27.6" x 5.9"	(27.6" x 27.6" x 5.9") x 2
Net Weight	253 lb (115 kg)	403.4 lb (183 kg)
Net Dimensions (WDH)	43" x 39.8" x 16.9"	43" x 39.8" x 29.5"

### Proprietary Pizza Stone Technology

Thermographic test show that in a chamber heated this way, the desired temperature can be reached within a shorter time span and heat is distributed evenly.

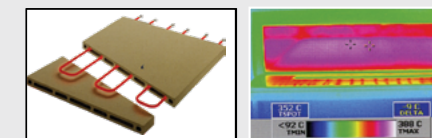

- Built with proprietary pizza stone technology, which allows heat to distribute evenly in a short frame of time
- Extremely high levels of performance, efficiency and reliability with low operating costs
- Ideal for pizza baking as well as baking/warming other food such as pasta, lasagne and tortillas
- Item 40641 and 40643 can bake up to twelve 13" pizzas at a time
- Mechanical version, the temperature is set by the top and bottom thermostats and is displayed on the mechanical thermometer
- Digital version has an electronic card that is used to program the start, end of baking and two work settings
- Both versions feature safety thermostat and independent chambers
- Upon request, some models can be produced with single-phase voltage

### 41" x 28" Double Chambers



40641

40643

Digital display

	Mechanical Control	Digital Control
Item	40641	40643
Model	PE-IT-0049-D	PE-IT-0049-DD
Capacity (ea. chamber)	Six 12" or 13" pizzas / Two 18" pizzas or Two 24" x 16" pizzas	
Maximum Temperature	450°C (842°F)	
Electrical	230V / 60Hz / 3Ph	
Power	18 kW	18 kW
Chamber Dimensions (WDH)	(41.3" x 27.6 x 5.9") x 2	(41.3" x 27.6" x 5.9") x 2
Net Weight	509 lb (231 kg)	520 lb (236 kg)
Net Dimensions (WDH)	56.9" x 39.8" x 29.5"	

### Optional Accessories (Sold Separately)

Item	Description	Item	Description
41604	Stainless Steel Stand for item 40637	41603	Stainless Steel Hood for Item 40637 and 40638
41605	Stainless Steel Stand for item 40638	40644	Stainless Steel Hood for Item 40641 and 40643
40642	Stainless Steel Stand for item 40641, 40643	40645	Wheels for Item 40637, 40638, 40641 and 40643

## Entry Max Series Ovens



- Stainless steel front, two mechanical thermostats and one analogical control thermometer per chamber, heat resistant light, main switch for each chamber, stainless steel door with glass and handle (Each chamber is independent)
- Can place up to 2 single-chamber oven on top of each other without the need for an exhauster connection
- Ideal for pizza baking as well as baking/warming other food such as pasta, lasagne and tortillas

	Single Chamber	Double Chamber / 3Ph	Double Chamber / 1Ph
Item	40635	40636	45199
Model	PE-IT-0019-S	PE-IT-0038-D	PE-IT-0038-DS
Capacity (ea. chamber)	Four 12" or 13" pizzas / One 18" pizza or One 24" x 16" pizza		
Temperature	450°C (842°F)		
Power	5.6 kW	11.2 kW	
Electrical	230V / 60Hz / 3Ph	230V / 60Hz / 3Ph	230V / 60Hz / 1Ph
Chamber Dimensions (WDH)	27.6" x 27.6" x 5.9"	(27.6" x 27.6" x 5.9") x 2	
Net Weight	163 lb (74 kg)	328.5 lb (149 kg)	
Net Dimensions (WDH)	39" x 36.2" x 14.9"	39" x 36.2" x 26.7"	
Optional Accessories (Sold Separately)	Stainless Steel Stand (Item 41600), Stainless Steel Hood (Item 41607)Wheels (Item 40645)	Stainless Steel Stand (Item 41422), Stainless Steel Hood (Item 41607), Wheels (Item 40645)	

## Compact Series Ovens

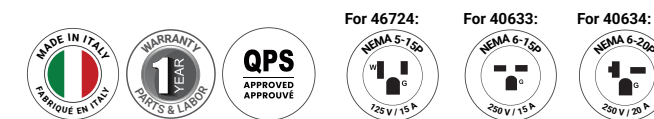

- The Compact Series pizza ovens are practical and functional with a refractory brick baking surface.
- These ovens are ideal for pizzas, bread and kitchen products (semi-processed). Up to 3 chambers can be placed on top each other (dependent on the type of oven).
- Stainless steel structure, interior light, thermal insulation and jacket, stainless steel door with glass and handle
- Easy to use for baking/warming up variety of food such as tortillas, hamburgers, panini, pizza slices and even frozen food
- Ideal for snack bars, taverns, restaurants, pubs and fast food operations

	110V	230V / 14" dia. chamber	230V / 20" dia. chamber
Item	46724	40633	40634
Model	PE-IT-0005-110V	PE-IT-0005	PE-IT-0010
Output per hour	15		
Capacity	One 12" or 13" Pizza	One 12" or 13" Pizza	Two 10" or One 18" Pizza
Max Temperature	450°C (842°F)		
Power	2,200 W	2,220 W	3,600 W
Electrical	110V / 60Hz / 1Ph	230V / 60Hz / 1Ph	
Chamber Dimensions (WDH)	13.75" x 13.75" x 3.3"	13.75" x 13.75" x 3.3"	19.6" x 19.6" x 5.11"
Net Weight	66 lb (30 kg)	66 lb (30 kg)	77 lb (35 kg)
Net Dimensions (WDH)	22.8" x 19.6" x 11.3"	22.8" x 19.6" x 11.3"	29.3" x 26" x 12.6"

# Panini Grills

Grill your signature sandwiches to perfection with our great selection of panini grills. These grills are ideal for quesadillas, paninis, hamburgers, focaccia, and pita sandwiches. These units have a stainless steel body with cast iron grilling surfaces for easy cleaning. The double grills feature independent controls for each grilling side.

Non-Stick ceramic treated cast iron ensures easy cleaning, extreme durability, and does not chip, peel, or scratch.



## Single Panini Grills

- Stainless steel body with cast iron grilling surfaces
- Functioning pilot lamp
- Non-slip rubber feet
- Panini grill cleaning brush included



	10" x 9" Grooved Top & Bottom	10" x 9" Grooved Top & Smooth Bottom	10" x 14" Grooved Top & Bottom
Item Number	11375	11376	11377
Model	PG-IT-0483-R	PG-IT-0483	PG-IT-0610-R
Grill Surface	10" x 9"		10" x 14"
Top Grill Surface	Grooved	Grooved	Grooved
Bottom Grill Surface	Grooved	Smooth	Grooved
Thermostat Control	299°C (570°F)		
Power	1,700 W		
Amps	15 A	14 A	15 A
Electrical	110V / 60Hz / 1Ph	120V / 60Hz / 1Ph	110V / 60Hz / 1Ph
Net Weight	40 lb (18 kg)	35 lb (16 kg)	53 lb (24 kg)
Net Dimensions (WDH)	14.4" x 11.4" x 19.75"	14.4" x 11.4" x 19.75"	14.4" x 15" x 19.75"

## Double Panini Grills

- Stainless steel body with cast iron grilling surfaces
- Functioning pilot lamp
- Non-slip rubber feet
- Panini grill cleaning brush included



	10"x19" Grooved Top & Bottom	10"x19" Grooved Top & 1/2 Smooth 1/2 Grooved Bottom
Item Number	11378	11380
Model	PG-IT-0737-R	PG-IT-0737
Grill Surface	10" x 19"	
Top Grill Surface	Grooved	Grooved
Bottom Grill Surface	Grooved	1/2 Smooth, 1/2 Grooved
Thermostat Control	300 °C (572 °F)	
Power	3,000 W	
Amps	13 A	
Electrical	220V / 60Hz / 1Ph	
Net Weight	56 lb (25 kg)	70 lb (31.75 kg)
Net Dimensions (WDH)	21" x 12.75" x 19.75"	20.25" x 12.75" x 19.75"

# Cort Series Single Panini Grill

Easily adjusted hinge mechanism and the self balancing top cooking surface ensures easy operations and service of the grill.

Front mounted grease receptacle allows for easy cleaning and sanitization between work periods.

Item Number	48603
Model	PG-IT-0381
Grill Surface	15" x 10"
Top Grill Surface	Grooved
Bottom Grill Surface	Smooth
Thermostat Control	300 °C (572 °F)
Power	1,700 W
Amps	14 A
Electrical	120V / 60Hz / 1Ph
Net Weight	48 lb (22 kg)
Net Dimensions (WDH)	18" x 15" x 9.5"



## SMOOTH Top & Bottom

.....

This configuration is ideal for even and complete contact for your food such as grilled cheese sandwiches, quesadillas, and hamburgers.



## (Dual) GROOVED/SMOOTH Top & Bottom

.....

We also offer units with a split cast iron surface with grooved on one side and smooth on the other making it perfect for high volume operations.

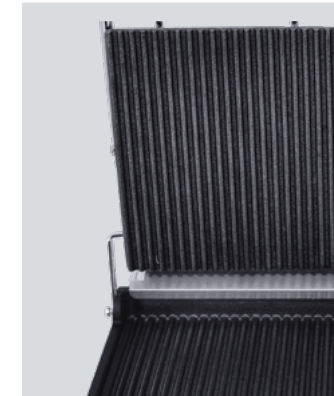

## GROOVED Top & Bottom

.....

The grooved surface on the grills provides grill marks to the meat or sandwich making it more visually appealing for your customers.



## GROOVED    SMOOTH Top                      Bottom

.....

If versatility is what you are looking for, look no further as this panini grill offers the best of both worlds. The smooth surface can be used as a griddle/warmer while the grooved surface creates appealing grill marks.

# Pasta Cookers

## Natural Gas Double Tank Pasta Cooker



### Unmatched Performance

The most versatile pasta cookers on the market today, single burner models are great for cooking fresh, dry or partially cooked refrigerated pasta, and double burner models are great for cooking frozen pasta due to fast recovery times. These pasta cookers are not limited to pasta, and can cook items such as rice, vegetables, potato and seafood.

Tanks are stamped from a single piece of AISI #316 stainless steel, and is highly resistant to corrosion due to salt water. A blanket of ceramic fiber insulates each tank, virtually eliminating hot surfaces while providing better efficiency and performance.

Burner design concentrates heat at the rear, and creates a natural convective flow that stirs the pasta without need for manual tossing. This also moves starches into a skim drain, keeping the water starch free.

\*LPG Conversion Kit included

- Auto starch removal
- Corrosion resistant
- Convective design stirs itself while cooking
- Double burner models for cooking frozen foods
- Insulated tanks help prevent injuries

Item Number	49099	49100
Model	CE-IT-0090	CE-IT-0090PLUS
Material	Stainless Steel	Stainless Steel
Thermal Power	95,000 BTU /hr	156,000 BTU /hr
Tank Volume	2 x 11.89 gal.	2 x 11.89 gal.
Net Weight	264.5 lbs (120 kg)	271 lbs (123 kg)
Net Dimensions	35.43" x 35.43" x 45.78" (900 x 900 x 1100 mm)	35.43" x 35.43" x 45.78" (900 x 900 x 1100 mm)
Gross Weight	302 lbs. (137 kg)	308.6 lbs. (140 kg)
Gross Dimensions	39.3" x 43.3" x 51.2" (1000 x 1100 x 1300 mm)	39.3" x 43.3" x 51.2" (1000 x 1100 x 1300 mm)



49099



49100

## Natural Gas Single Tank Pasta Cooker



- Slimmer single tank size to fit space constraints, or smaller operational volumes.
- Same quality, smaller package.
- \*LPG Conversion Kit included

Item Number	49097	49098
Model	CE-IT-0045	CE-IT-0045PLUS
Material	Stainless Steel	Stainless Steel
Thermal Power	47,500 BTU /hr	78,000 BTU /hr
Tank Volume	1 x 11.89 gal.	1 x 11.89 gal.
Net Weight	143.3 lbs (65 kg)	147.7 lbs (67 kg)
Net Dimensions	17.72" x 35.43" x 43.30" (450 x 900 x 1100 mm)	17.72" x 35.43" x 43.30" (450 x 900 x 1100 mm)
Gross Weight	170 lbs. (77 kg)	174 lbs. (79 kg)
Gross Dimensions	23.6" x 43.3" x 51.2" (600 x 1100 x 1300 mm)	23.6" x 43.3" x 51.2" (600 x 1100 x 1300 mm)



## Pasta Cooker Baskets

Item	Item Number
1/1 Full Size, Double Handle	49149
1/2 Half Size, Double Handle	49150
1/3 Third Size, Double Handle	49106
1/6 Sixth Size Square, Left Handle	49107
1/6 Sixth Size Square, Right Handle	49108
1/6 Sixth Size Round, One Handle	49151



49098



49097

# Patty Making

## Top-Down Patty Press- OMAS



- Provide quick forming of patties with cellophane sheets
- Made of anodized aluminum and food contact areas made of stainless steel
- Simple to operate and easy to clean
- Cellophane papers are available separately

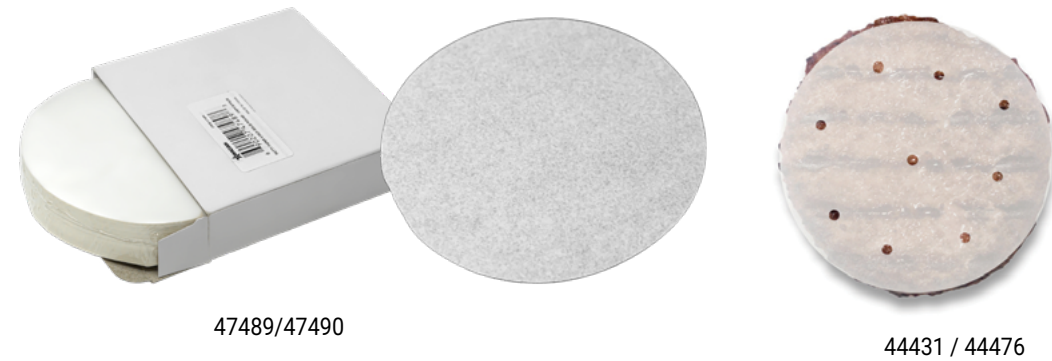

### Solid/ Perforated Round Patty Paper

- An ideal choice for hamburger patty presses
- Wax-coated paper designed to resist grease and juices
- Non-stick perforated design prevents moisture build-up
- Excellent choice for butcher shops, delis, markets and grocery stores

Item	47489	44431	47490	44476
Description	4" Solid Round Patty Paper	4" Perforated Round Patty Paper	5" Solid Round Patty Paper	5" Perforated Round Patty Paper
Compatible	11426 - Hamburger Press Patty Maker		11428 - Hamburger Press Patty Maker with 5.2" Diameter	
Quantity/Case (pcs.)	500pcs	500pcs	500pcs	500pcs



Item	11426	11428
Model	BT10	BT13
Description	4" Diameter Patty Machine	5.2" Diameter Patty Machine
Capacity	6.75 oz max.	10 oz max.
Net Weight	10 lb / 4.5 kg	10 lb / 4.5 kg
Net Dimensions	10.25" x 8.6" x 11"	11" x 10" x 13"
Optional Item	11427	11429
Description	Cellophane Paper 2.2 lb - Approx. 1000 sheets for 11426	Cellophane Paper 2.2 lb - Approx. 1000 sheets for 11428





# Dough Processing

Dough Mixers	89
Dough Rollers	97
Dough Rounders	99
Dough Sheeter	103
Pasta Sheeter	105
Pasta Extruder	107
Ravioli Machine	114
Pasta Die Guide	115

# 04

# Dough Mixers

## Fork Mixers

### Single Speed 26 Qt Dough Fork Mixer

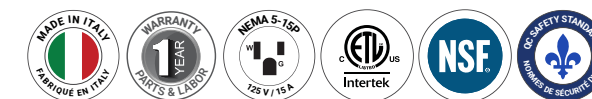

- This unit comes equipped with a high quality stainless steel bowl, fork, holder shaft and bowl guard
- Body is manufactured powder-coated steel that houses all transmission and mechanical components
- Equipped with powerful motor, trapezoidal belts, and two reduction gears that work independently for the bowl and fork
- The rotating parts are assembled on ball-bearings
- Capable of kneading of up to 25 kilograms of dough
- The electrical system and safety devices conform to European Regulations
- Comes with a built in timer



### Santos #18 10 Qt Dough Fork Mixer



- Equipped with a silent motor and a helical fork
- Ideal to knead 9 lb (4 kg) of hard dough within approximately 15 minutes
- Lift gap located on the side is used to safely add ingredients while mixing dough
- Transparent cover automatically works in complete safety by stopping when the lid is open
- Operates like a baker's dough mixer
- Ideal for all kinds of bread and pizza dough

Item	45637
Model	SANTOS 18
Bowl Capacity	10.6 qt
Fork Speed	84 RPM
Power	650 W / 0.87 hp
Amps	6 A
Electrical	110V / 60Hz / 1Ph
Net Weight	40 lb (18 kg)
Net Dimensions (WDH)	15" x 15" x 17"



Item	44256
Model	MX-IT-0025
Maximum Kneading Capacity	55 lb (25 kg) (9L of water; 16 kg of flour) Maximum capacity may vary depending on the ingredients
Bowl Capacity	26.40 qt / 30 L
Bowl RPM	9
Fork RPM	28
Power	1,500 W / 2 hp
Amps	6.6A
Electrical	200-240 V / 60 Hz / 1Ph
Net Weight	315.26 lb (143 kg)
Net Dimensions (WDH)	34.25" x 22.05" x 35.04"

The fork attachment smoothly simulates the turning motion of human hands, quickly achieving a natural leavening process without unnaturally warming the dough.



# Dough Mixers

## Spiral Mixers

### Fixed Bowl

### Removable Bowl



For 47087 & 47287 For 47088 & 47288

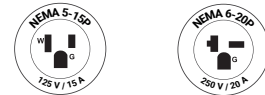

- Made from large thickness C40 steel
- Scratch resistant powder coating
- The bowl is made with reinforced edge and AISI 304 stainless steel shaft
- Forged spiral tool
- Lid with opening to add ingredients during operation
- High efficiency ventilated motor with oil-bath gear box
- Thermal overload protection circuit breaker



47087 / 47088

47287/47288

	22 qt Bowl	22 qt Bowl with Timer	34 qt Bowl	34 qt Bowl with Timer
Item	47087	47287	47088	47288
Model	MX-IT-0020-R	MX-IT-0020-RT	MX-IT-0030-R	MX-IT-0030-RT
Bowl Capacity	22 qt		34 qt	
Max Dry Flour Capacity	23 lb (10.5 kg)		34 lb (15.5 kg)	
Max Dough Capacity	37.5 lb (17 kg)		55 lb (25 kg)	
RPM (Bowl/Spiral)	10 / 85		10 / 85	
Bowl Dimensions	Ø 14.2" x 8.3"		Ø 15.7" x 10.2"	
Power	750 W / 1 hp		1,100 W / 1.5 hp	
Amps	6.25 A		5 A	
Electrical	120V / 60Hz / 1Ph		220V / 60Hz / 1Ph	
Net Weight	184.1 lb (83.5 kg)		239.1 lb (108.5 kg)	
Net Dimensions (WDH)	29.6" x 15.7" x 44.3" (Open Lid: 44.3")		32.4" x 17.3" x 49.6" (Open Lid: 49.6")	



47417 / 47418

45417 / 45418

	22 qt Bowl	22 qt Bowl with Timer	34 qt Bowl	34 qt Bowl with Timer
Item	45417	47417	45418	47418
Model	MX-IT-0020-F	MX-IT-0020-FT	MX-IT-0030-F	MX-IT-0030-FT
Bowl Capacity	22 qt		34 qt	
Max Dry Flour Capacity	23 lb (10.5 kg)		34 lb (15.5 kg)	
Max Dough Capacity	37.5 lb (17 kg)		55 lb (25 kg)	
RPM (Bowl/Spiral)	10 / 85		10 / 85	
Bowl Dimensions	Ø 14.2" x 8.3"		Ø 15.7" x 10.2"	
Power	750 W / 1 hp		1,100 W / 1.5 hp	
Amps	11.3 A		8 A	
Electrical	120V / 60Hz / 1Ph		220V / 60Hz / 1Ph	
Net Weight	153.7 lb (69.7 kg)		210.3 lb (95.4 kg)	
Net Dimensions (WDH)	26.8" x 15.4" x 24.6" (Open Lid: 37.4")		29.1" x 17.3" x 27.6" (Open Lid: 41.3")	

- Made from large thickness C40 steel
- Scratch resistant powder coating
- The bowl is made with reinforced edge and AISI 304 stainless steel shaft
- Forged spiral tool
- Lid with opening to add ingredients during operation
- High efficiency ventilated motor with oil-bath gear box
- Thermal overload protection circuit breaker



For 45417 & 47417

For 45418 & 47418

# Heavy Duty Spiral Mixers



FOR 13160, 13163, 13167, 13171



FOR 13162, 13166, 13170, 13171, 13172, 13173, 13174



13160/13162/18637



13163/13166



13167



13170/13171/13172/13173/13174

- Stainless steel construction.
- Fixed stainless steel high strength spirals as well as a safety device which stops the machine when the bowl cover is lifted.
- Greatly reduce the usual mixing time of traditional machines.
- Ideal for bakeries and pizza shops, these mixers performs well with hard and soft dough.

Dough Mixer

Dough Mixer

04 DOUGH PROCESSING

04 DOUGH PROCESSING

	13 qt	13 qt	13 qt	24 qt	24 qt
Item	13160	13162	18637	13163	13166
Model	MX-IT-0010	MX-IT-0010-T	MX-IT-0010-D	MX-IT-0020	MX-IT-0020-T
Bowl Capacity	13 qt		13 qt	24 qt	
Max Dry Flour Capacity	14 lb (6 kg)		14 lb (6 kg)	24 lb (11 kg)	
Max Dough Capacity	22 lb (10 kg)		22 lb (10 kg)	40 lb (17 kg)	
HP	0.75 hp 1 speed		0.6 / 0.4 hp 2 speeds	1.2 hp 1 speed	1.5 / 1 hp 2 speeds
Bowl RPM	11		6 - 1st speed 12 - 2nd speed	9	6 - 1st speed 12 - 2nd speed
Hook RPM	126		63 - 1st speed 126 - 2nd speed	103	60 - 1st speed 120 - 2nd speed
Power	550 W		450 / 300 W	900 W	1100 / 750 W
Amps	2.5 A		2.2 / 1.44 A	4 A	3.8 A / 2.6 A
Electrical	220V / 60Hz / 1Ph	208V / 60Hz / 3Ph	208V / 60Hz / 3Ph	220V / 60Hz / 1Ph	208V / 60Hz / 3Ph
Net Weight	103 lb (46.7 kg)		103 lb (46.7 kg)	161 lb (73 kg)	161 lb (73 kg)
Net Dimensions	20.5" x 11" x 23"		20.5" x 11" x 23"	27" x 15.4" x 26.4"	27" x 15.4" x 26.4"

	40 qt	40 qt	52 qt	52 qt	67 qt	90 qt
Item	13167	13170	13171	13172	13173	13174
Model	MX-IT-0030	MX-IT-0030-T	MX-IT-0040	MX-IT-0040-T	MX-IT-0050	MX-IT-0060
Bowl Capacity	40 qt	40 qt	52 qt	52 qt	67 qt	90 qt
Max Dry Flour Capacity	40 lb (18 kg)	40 lb (18 kg)	55 lb (25 kg)	55 lb (25 kg)	69 lb (31 kg)	82 lb (37 kg)
Max Dough Capacity	66 lb (30 kg)	66 lb (30 kg)	88 lb (40 kg)	88 lb (40 kg)	110 lb (50 kg)	132 lb (60 kg)
HP	1.5 hp 1 speed	1.9 / 1.5 hp 2 speeds	1.5 hp 1 speed	1.9 / 1.5 hp 2 speeds	4 / 2 hp 2 speeds	4 / 2 hp 2 speeds
Bowl RPM	7	6 - 1st speed 12 - 2nd speed	7	6 - 1st speed 12 - 2nd speed	4.5 - 1st speed 9 - 2nd speed	7 - 1st speed 14 - 1st speed
Hook RPM	95	64 - 1st speed 128 - 2nd speed	95	64 - 1st speed 128 - 2nd speed	60 - 1st speed 120 - 2nd speed	70 - 1st speed 140 - 2nd speed
Power	1100 W	1400 / 1100 W	1100 W	1400 W / 1100 W	3000 / 1500 W	3000 / 1500 W
Amps	5 A	4.8 / 3.8 A	5 A	4.8 / 3.8 A	10 / 5.2 A	10 / 5.2 A
Electrical	220V / 60Hz / 1Ph	208V / 60Hz / 3Ph	220V / 60Hz / 1Ph	208V / 60Hz / 3Ph	208V / 60Hz / 3Ph	
Net Weight	246 lb (111.6 kg)		273 lb (123.8 kg)		407 lb (184.6 kg)	407 lb (184.6 kg)
Net Dimensions	30" x 16.5" x 36"		32" x 19" x 37.4"		37" x 21" x 40.5"	39" x 23" x 42"

# 107 Qt Heavy Duty Spiral Dough Mixer



- **Stainless Steel guard** is ergonomically designed and completely safe. When guard is opened at a 90° angle, this spiral dough mixer automatically stops working.
- **Simple Action Function Access:** two working speeds, two times and an automatic cycle.

Item	44269
Model	MX-IT-0060-M
Bowl Capacity	107 qt
Max Dry Flour Capacity	82 lb (37 kg)
Max Dough Capacity	132 lb (60 kg)
Bowl RPM	21
Spiral RPM	1st speed: 104 RPM 2nd speed: 208 RPM
Spiral Motor	1,000 - 4,000 W
Power	3,700 W
Bowl Dimensions	23.6" x 14.2 (600 x 360 mm)
Electrical	208V / 60Hz / 3Ph
Net Weight	683.4 lb (310 kg)
Net Dimensions (WDH)	25" x 43.7" x 47.2"

# 143-164 Qt Heavy Duty Spiral Dough Mixer



- **Intuitive Interface** allows you to access all functions with a few simple actions: two work speeds, two times and an automatic cycle.
- **Bowl & Spiral:** Both are made from high-resistance stainless steel. The design, dimensions and sizing have all been carefully devised to ensure a peerless finished product.
- **Stunning Dough:** Designed to help you create a dough with perfect, handmade consistency. This mixer has a reinforced spiral drive mechanism specially designed for dryer dough mixes.
- **Highly Safe:** The protective grill in stainless steel is ergonomically designed and completely safe. When opened the machine automatically stops working.
- **Solid Stability:** The feet give the machine great stability, while the wheels mean that the machine can be moved easily in order to clean the workspace.
- **User-friendly At All Times:** A special button means you can respond to emergencies quickly, in accordance with the regulations out there.

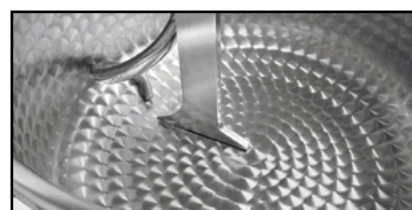

	143 qt	164 qt
Item	49122	49123
Model	MX-IT-0080-M	MX-IT-0100-M
Bowl Capacity	143 qt	164 qt
Max Dry Flour Capacity	110 lb (50 kg)	138 lb (63 kg)
Max Dough Capacity	176 lb (80 kg)	220 lb (100 kg)
Timer	2	
RPM	2	
Wattage	Spiral: 2,400 W / 4,400 W Bowl: 5,600 W	Spiral: 2,400 W / 4,400 W Bowl: 5,600 W
Power	Spiral: 1,000 - 4,000 W Bowl: 370 W	Spiral: 2400 - 4,500 W Bowl: 560 W
Amps	Spiral: 8.3 A - 15.26 A Bowl: 19.4 A	Spiral: 8.3 A - 15.26 A Bowl: 19.4 A
Electrical	208V / 60Hz / 3Ph	
Bowl Diameter	27.6"	27.6"
Bowl Height	14.2"	16.1"
Net Weight	925.9 lb (420 kg)	992.1 lb (450 kg)
Net Dimensions (WDH)	29.1" x 48" x 49.2"	29.1" x 48.4" x 49.2"

# Dough Rollers

## Adjustable Dough Roller with 13.3" Max Roller Width

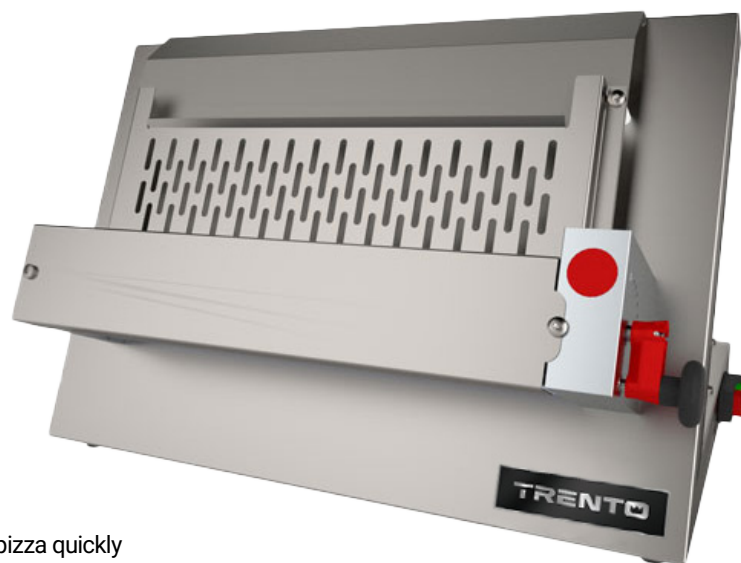

- Simple and economical machines
- Essential for restaurants that want to prepare pizza quickly
- Adjustable thickness (0.1 - 0.4mm) in increments of 0.2mm
- Not set up for the use of electric pedal

	13.3" Max Roller Width	15.75" Max Roller Width
Item	40639	40640
Model	BE-IT-0337	BE-IT-0400
Capacity	0.29 m <sup>3</sup> / 10.2 cu.ft.	0.18 m <sup>3</sup> / 6.3 cu.ft.
Dough Weight	2.8-14.1 oz. / 80-400 g	7.4-21.2 oz. / 210-600 g
Pizza Diameter	5.5"-13.4"/ 140-340 mm	10.2" - 15.75"/ 260-400 mm
Power	0.5 hp / 370 W	0.5 hp / 370 W
Electrical	110V / 60Hz / 1Ph	110V / 60Hz / 1Ph
Net Weight	48.4 lb (22 kg)	57.3 lb (26 kg)
Gross Weight	57.2 lb (26 kg)	64 lb (30 kg)
Net Dimensions (WDH)	20.5" x 17.4" x 15"	23" x 17.4" x 15"
Gross Dimensions	21" x 27" x 20"	27" x 20" x 21"

## Adjustable Dough Roller with 15.75" Max Roller Width



- Saves time in the rolling of pizza dough
- Dough is not heated in the process and its characteristics are not affected
- Thickness and diameter can easily be adjusted

Item	13177
Model	BE-IT-0406
Dough Weight	7.5 - 24.5 oz. / 213 - 695g
Pizza Diameter	11" - 15.75"
Power	0.5 hp / 370 W
Electrical	110-120V / 60Hz / 1Ph
Net Weight	77.2 lb (35 kg)
Net Dimensions (WDH)	18.5" x 21" x 32"

# Dough Rounders & Dividers

Dough Rounders

Dough Rounders

## Bun Rounding Divider



Manual



Automatic

- Powered by hydraulics
- 2 cylinders for pressing, 1 cylinder for cutting, & 1 for rounding.
- Knife cleaning button.
- Control panel to adjust pressing, rounding and shaping chamber opening times.
- Can store up to 9 different programs

	Manual 15-Division / 3Ph	Manual 15-Division / 1Ph	Manual 30-Division / 3Ph	Manual 30-Division / 1Ph
Item	47582	48582	47583	48583
Model	BE-IT-0015M	BE-IT-15M-1P	BE-IT-0030M	BE-IT-30M-1P
Number of Divisions	15		30	
Min. Product Weight	150g		40g	
Max. Product Weight	360g		135g	
Basin Capacity	12.1 lb (5.5 kg)		8.8 lb (4 kg)	
Head Diameter	15.7"			
PSI per Hour	261			
Electrical	220V / 60Hz / 3Ph	220V / 60Hz / 1Ph	220V / 60Hz / 3Ph	220V / 60Hz / 1Ph
Net Weight	396.8 lb (180 kg)			
Net Dimensions (WDH)	24" x 26.8" x 80.7"			

	Automatic 15-Division / 3Ph	Automatic 15-Division / 1Ph	Automatic 30-Division / 3Ph	Automatic 30-Division / 1Ph
Item	47581	48580	47580	48581
Model	BE-IT-0030A	BE-IT-15A-1P	BE-IT-0015A	BE-IT-30A-1P
Number of Divisions	15		30	
Min. Product Weight	150g		40g	
Max. Product Weight	360g		135g	
Basin Capacity	12.1 lb (5.5 kg)		8.8 lb (4 kg)	
Head Diameter	15.7"			
PSI per Hour	261			
Electrical	220V / 60Hz / 3Ph	220V / 60Hz / 1Ph	220V / 60Hz / 3Ph	220V / 60Hz / 1Ph
Net Weight	540 lb (245 kg)			
Net Dimensions (WDH)	26" x 27.6" x 57.1"			
Gross Dimensions	30" x 29" x 66"			

O4 DOUGH PROCESSING

O4 DOUGH PROCESSING

# Dough Press / Pizza Shaper



- Ideal choice for high-demand pizzerias and restaurants
- Continually forms pizza bases for up to 24-hours and can be easily used by non-specialized operators
- Designed with a built-in automotive self-breaking motor, cam, stop timer, and non-stick aluminum plates, this steel structure is built for durability

Item	45356
Model	BE-IT-0045
Plates Temperature	130°C to 170°C / 266°F to 338°F
Dough Size	17.7"
Power	8,100 W
Electrical	230V / 60Hz / 1Ph
Dough Weight	551.15 - 1102.31 lb (250 - 500 kg)
Net Weight	280 lb (127 kg)
Net Dimensions (WDH)	24.8" x 26.4" x 35"

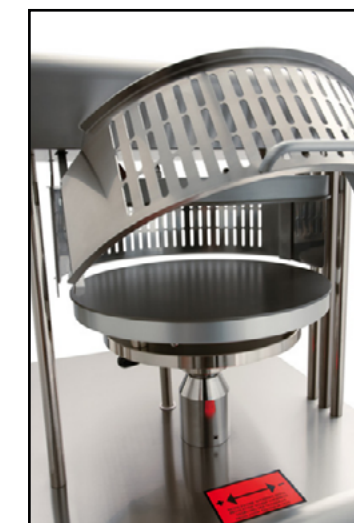
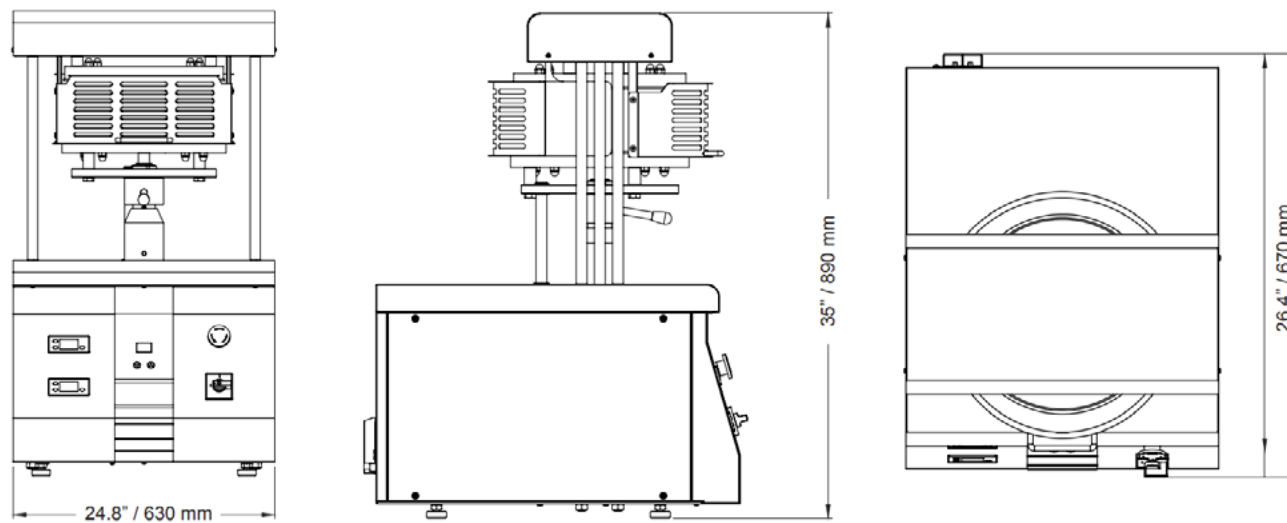

# Dough Sheeters

## 11-17 lb Dough Sheeters



- Aluminum die-cast shoulders and casing.
- Possibility of working all types of dough, obtaining very thin results.
- Galvanized hard chrome plated, ground and polished cylinders.
- Easy to remove scrapers, for quick and efficient cleaning.
- Adjustable belt speeds to prevent dough wrinkling.
- Folding tables to reduce machine space when not in use.
- Low voltage electrical system with dual commands (hand and foot pedal)
- Accident prevention safety guards connected to the electrical system by limiting switches
- Machine mounted on 360 swivel wheels making it fully mobile.

	28" Floor Model	48" Floor Model	60" Floor Model
Item	48763	48764	48765
Model	BE-IT-0710	BE-IT-1200	BE-IT-1500
Max. workable dough quantity	11 lb (5kg)	17.6 lb (8 kg)	17.6 lb (8 kg)
Min/max rolling thickness	0-1.4" (0 - 35 mm)	0-1.57" (0-40 mm)	
Max belts speed in/out	0.275 - 0.475 m/s	0.303/0.513 m/s	
Power	1hp / 750 W		
Electrical	220V / 60Hz/ 1 Ph		
Table Length	28" / 710 mm	48" / 1200 mm	60"/1500 mm
Table Width	23.6" / 600 mm	23.6" / 600 mm	23.6" / 600 mm
Net Weight	326.3 lb (148 kg)	513.7 lb. (233 kg)	540 lb (245 kg)
Working Dimensions	70.8" x 34.6" x 43.3"	109.4" x 39.8" x 45.7"	133.1" x 39.8" x 45.7"
Closed Dimensions	23.6" x 34.6" x 57.5"	35.4" x 39.8" x 77.2"	41.7" x 39.8" x 88.6"



### Updated Features for 2025 Models

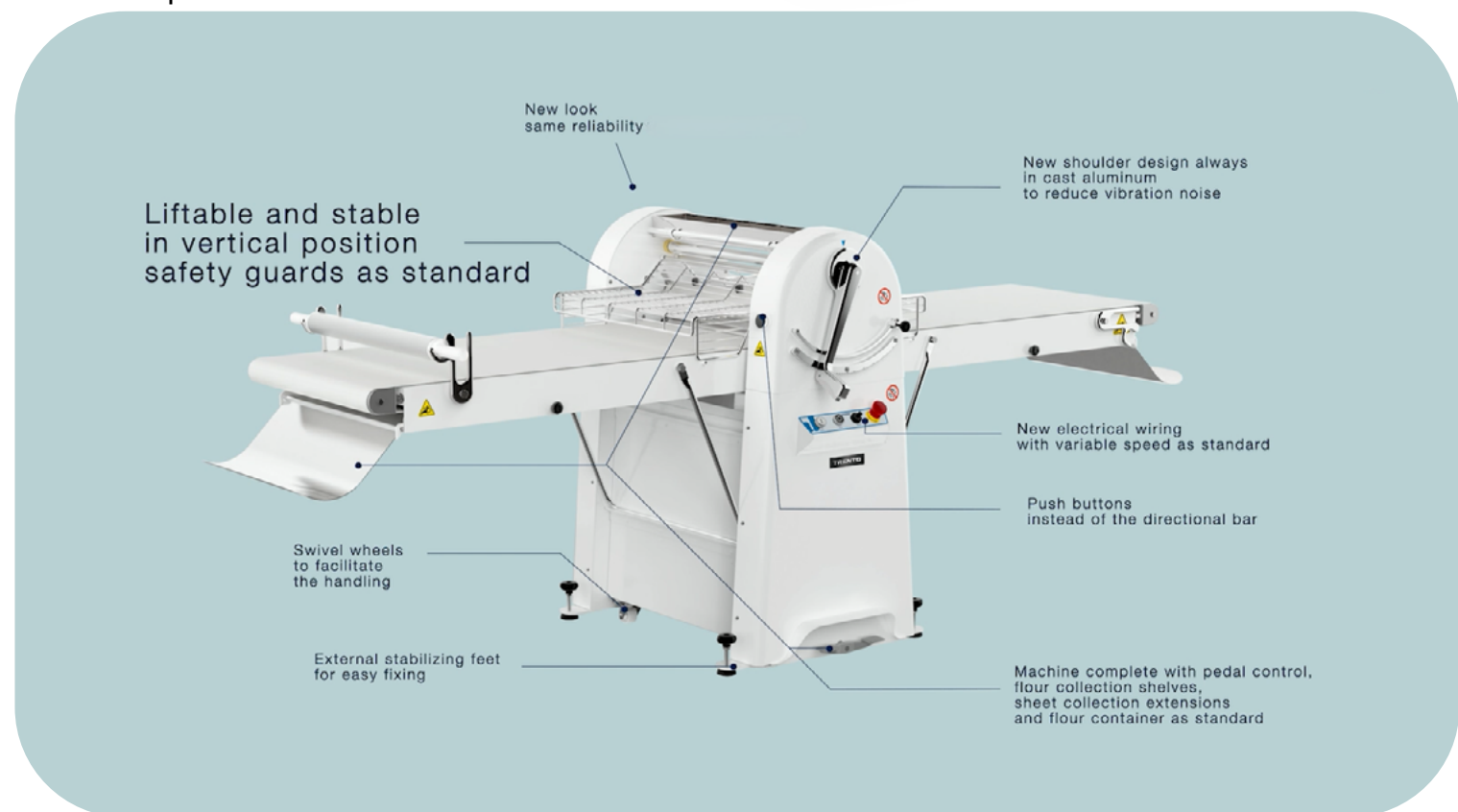

# Pasta Sheeters

## European Style Residential Electric Pasta Sheeter



- Quickly makes sheets of pasta in six different thickness
- Cuts it into two types of pasta: tagliatelle (2mm) and fettuccine (6.5mm)
- Ideal for home use

Item	13234
Model	PM-IT-0146
Roller Width	5 3/4"
Max. Roller Opening	1.9 mm
Roller Revolution Speed	36 min / 48 Max.
Nominal Power	85W
Electrical	120V / 60Hz / 1Ph
Net Weight	13 lb (5.91 kg)
Net Dimensions	10.5" x 8.25" x 10.5"

Optional Cutters

- Spaghetti Ø 2mm (Item 16991),
- Capelli d' Angelo 1.5mm (Item 16988),
- Trenette 4mm (Item 16989),
- Lasagnette 12mm (Item 16990)

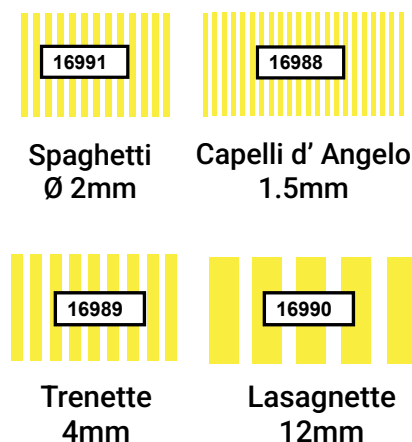
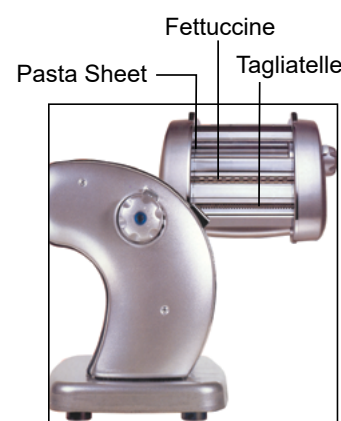

## European Style Commercial Pasta Sheeter



- Ideal for restaurants and demanding home use
- Bodies are stainless steel construction and allow for easy cleaning
- Designed for flat noodle production

	Manual Pasta Sheeter	Electric Pasta Sheeter
Item	13231	46292
Model	PM-IT-0210-M	PM-IT-0037
Roller Length	8.25"	8.25"
Roller Opening	9.5 mm (Max.)	50 mm (Max.)
Power	-	0.25 hp / 190 W
Electrical	-	110V / 60Hz / 1Ph
Net Weight	22 lb (10 kg)	35.5 lb (16.14 kg)
Net Dimensions (WDH)	8.5" x 12.75" x 9.75"	8.5" x 14" x 10"

Optional Items (for items 13231 & 46292)

- Item 46300 - 2mm Spaghetti Cutter, Round
- Item 46301 - 1.5mm N.1 Capelli D'angelo Cutter
- Item 46302 - 2mm N.2 Tagliatelle Cutter
- Item 46303 - 4mm N.3 Trenette Cutter
- Item 46304 - 6.5mm N.4 Fettuccine Cutter
- Item 46305 - 12mm N.5 Lasagnette Cutter
- Item 46306 - 12mm Reginette Lasagnette Cutter



13231



Cutter is sold separately

46292

# Pasta Extruders

## Countertop Heavy Duty Pasta Extruder



48226



13320

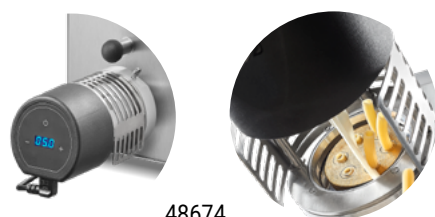

48674



40399



### 11/18 lb/hr

Dies are sold separately

	LP 5 Touch screen, 11 lb/hr	TR 70 Analog, 18 lb/hr
Item	48226	13320
Model	PM-IT-0005	PM-IT-0004
Dough Capacity	4 lb (1.8 kg)	5.5 lb (2.5 kg)
Output / Hr.	11 lb (5 kg)	18 lb (8 kg)
Power	0.5 hp / 370 W	0.5 hp / 370 W
Electrical	110 V / 60 Hz / 1Ph	110V / 60Hz / 1Ph
Net Weight	53 lb (24 kg)	61 lb (28 kg)
Net Dimensions (WDH)	9" x 19" x 11.4" (210 x 480 x 290 mm)	17.32" x 9.84" x 16.73" (250 x 440 x 425 mm)
Optional Item	Pro Cutter* (Item 48674) Multi-Tier Trolley (Item 48678)	Cutter assembly (Item 40399) Pro Cutter* (Item 48677) Multi-Tier Trolley (Item 48678)

\*Pro Cutter requires special blade for penne, available for special order

### 26.5 lb/hr TR 75-E

Dies are sold separately



49117

- All components that come into contact with food are made of stainless steel or food-grade bronze.
- All moving parts are installed on ball bearings with long-life seals or support with a grease gun.
- Single-motor-driven, belt drive with maintenance-free reduction gear. The mixer is driven by a sprocket
- Equipped with height-adjustable feet and plastic caps.
- Operating components can rotate in both directions.
- The operating parts are easy to disassemble to allow access for cleaning the machine.
- Allows you to make various pasta shapes by simply changing the die.
- Accessories supplied: liquid measuring jug, ring nut key, pasta tray.

Item	49117
Model	PM-IT-0012E
Dough Capacity	11 lb (5 kg)
Output Per Hour	26.5 lb (12 kg)
Power	1 hp / 750 W
Electrical	110V/ 60Hz / 1Ph
Material	Stainless steel body
Net Weight	105.8 lb (48 kg)
Net Dimensions (WDH)	12.2" x 20.1" x 22.4" (310 x 510 x 570 mm)
Optional accessories	Trolley for Pasta machine: 49119 Pro Cutter*: 48677 Cutter Motor Assembly for Pasta Machine: 49120 White Plastic Tray:40462



48678  
Optional multi-tier trolley for countertop models (comes with 5 pasta trays)

## Floor Model Heavy Duty Pasta Extruder

A heavy-duty floor model pasta extruder is essential for restaurants producing high volumes of fresh pasta consistently and efficiently. Unlike countertop variants, floor models are built for durability and sustained output, offering higher capacity, stronger motors, and advanced cooling systems that withstand continuous use. Water cooled pipes ensure that the unit does not overheat on extended use, preventing dry pasta. For busy kitchens aiming to serve authentic, house-made pasta without bottlenecks, a floor model extruder is not just a tool—it's a production powerhouse.



40462

49119

## 26.5 lb/hr TR 75 (with Cooling System)

Dies are sold separately



- All components that come into contact with food are made of stainless steel or food-grade bronze.
- All moving parts are installed on ball bearings with long-life seals or support with a grease gun.
- Single-motor-driven, belt drive with maintenance-free reduction gear. The mixer is driven by a sprocket
- Equipped with height-adjustable feet and plastic caps.
- Operating components can rotate in both directions.
- The operating parts are easy to disassemble to allow access for cleaning the machine.
- Allows you to make various pasta shapes by simply changing the die.
- Accessories supplied: liquid measuring jug, ring nut key, pasta tray, cutting assembly, trolley.
- Unit comes with a cooling pipe system to enable continuous operations.

Item	49118
Model	PM-IT-0012
Dough Capacity	11 lb (5 kg)
Output / Hr.	26.5 lb (12 kg)
Power	0.75 hp / 560 W
Electrical	110V / 60Hz / 1Ph
Net Weight	150 lb (68 kg)
Net Dimensions (WDH)	12.5" x 22" x 29" (320 x 750 x 725mm)
Gross Weight	153 lb (69.55 kg)
Gross Dimensions	29" x 22" x 29"
Optional accessories	Trolley for Pasta machine: 49119 Cutter Motor Assembly for Pasta Machine: 49120 White Plastic Tray:40462

## Need Extra Trays?

Pasta Tray	Item
24" x 16" x 4" Tray Perforated	81141
24" x 16" x 4" Tray Solid Base	81142
White Lid for Pasta Trays	81134



# Floor Model Heavy Duty Pasta Extruder

## 50 lb/hr TR 95 (with Cooling System)

Dies are sold separately

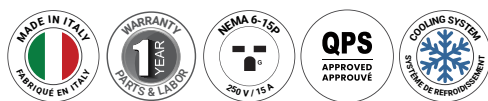

Item	13397
Model	PM-IT-0015
Dough Capacity	20 lb (9 kg)
Output / Hr.	50 lb (23 kg)
Power	1 hp / 750 W
Electrical	220V / 60Hz / 1Ph
Net Weight	253 lb (115 kg)
Net Dimensions (WDH)	15" x 35" x 34.6" (380 x 900 x 880mm)
Optional Item	Replacement white plastic tray (Item 40462)



13397

- Simply load all ingredients into the hopper, and then wait until the dough is extruded through the nozzle
- Sturdy construction and comes with a mobile stand for easy maneuverability during everyday use
- Features an included cutter assembly with adjustable cutting speed
- Comes with a built-in fan for faster drying time
- Unit comes with a cooling pipe system to enable continuous operations.

## 62 lb/hr TR 110 (with Cooling System)

Dies are sold separately



	220V / 62 lb (28 kg)	208V / 62 lb (28 kg)
Item	16643	13236
Model	PM-IT-0025	PM-IT-0025-T
Dough Capacity	33 lb (15 kg)	33 lb (15 kg)
Output / Hr.	62 lb (28 kg)	62 lb (28 kg)
Power	1.5 hp / 1,120 W	1.5 hp / 1,120 W
Electrical	220V / 60Hz / 1Ph	208V / 60Hz / 3Ph
Net Weight	297.6 lb (135.27 kg)	297.6 lb (135.27 kg)
Net Dimensions (WDH)	18.1" x 36.6" x 59" (460 x 930 x 1500mm)	18.1" x 36.6" x 59" (460 x 930 x 1500mm)
Optional Item	Replacement white plastic tray (Item 40462)	



16643



## 75 lb/hr TRD 110 Dual Tank Model (with Cooling System)

Dies are sold separately



Item	13440
Model	PM-IT-0040
Dough Capacity	First Tank: 26 lb (12 kg)   Second Tank: 17.6 lb (8 kg)
Output / Hr.	75 lb (34 kg)
Power	1.5 hp / 1,120 W
Electrical	208V/60Hz/3
Net Weight	385 lb (175 kg)
Net Dimensions (WDH)	22" x 40.5" x 36.6"
Optional Item	Replacement white plastic tray (Item 40462)

## Floor Model Heavy Duty Pasta Extruder

### 187 lb/hr TR 150 (with Cooling System)

Dies are sold separately



Item	13286
Model	PM-IT-0080
Dough Capacity	110 lb
Output / Hr.	187 lb (85 kg)
Power	5.5 hp / 4,100 W (worm) 2.5 hp / 1.86 (motor for paddle)
Electrical	208V / 60Hz / 3Ph
Net Weight	1146 lb (520 kg)
Net Dimensions (WDH)	33" x 53" x 69.3" (840 x 1350 x 1760mm)
Gross Weight	950 lb 431 kg)
Gross Dimensions	40" x 60" x 72"
Optional Item	Conveyor Belt (Item 46170), Pasta Mixer (Item 46171)

Unit comes with a cooling pipe system to enable continuous operations.



• For continuous operation, combining the NS TR Conveyor Belt and the MS 80 Pasta Mixer can produce a maximum output of **330 lb (150 kg)/hr**

# Ravioli Machine



Accessories sold separately

- Machine for the production of ravioli in various shapes and sizes
- Robust, safe and reliable,
- Suitable for pasta manufacturers, bakeries, delicatessens, supermarkets and catering for large groups
- 20-25 kg of ravioli per hour
- Stainless steel construction
- 1 mould included (Your selection from the Mould List\*)
- Easy mould replacement (Optional moulds available upon request - different shapes using the same machine)
- With any soft fillings (meat, cheese, vegetables)
- Easy regulation of filling amounts



Item	46296
Model	PM-IT-0030-R
Production	20-25kg / hour of ravioli
Width Of Pasta Sheet	4"
Power	0.33hp / 250 W
Electrical	220V/ 60Hz/ 1Ph
Net Weight	99 lb (45 kg)
Net Dimensions (WDH)	19" x 21.6" x 39" (500 x 550 x 1000mm)
Gross Weight	128 lb (58 kg)
Gross Dimensions	28" x 17.7" x 35"
Optional Item	46297 - Sheet roller for 46296 46298 - Special sheet die for 49118 to feed ravioli machine

#### \*Mould List Contact Us For More Details

Item	Description
47404	Ravioli Mould - Crescent, 2.75" x 1.5" (70x40mm)
47405	Ravioli Mould - Square, 1" (28mm)
47406	Ravioli Mould - Square, 1.75" (43 mm)
47407	Ravioli Mould - Square, 2" (55mm)
47408	Ravioli Mould - Triangle, 2"x 2.75" (60 x 50 mm)
47409	Ravioli Mould - Round, 1.75" (42mm)
47410	Ravioli Mould Oval 3.25" x 1.5" (83 x 70 mm)

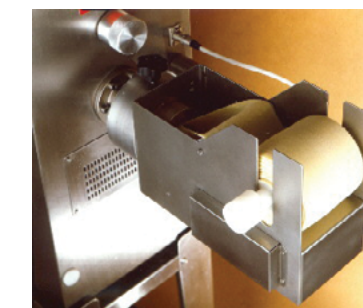





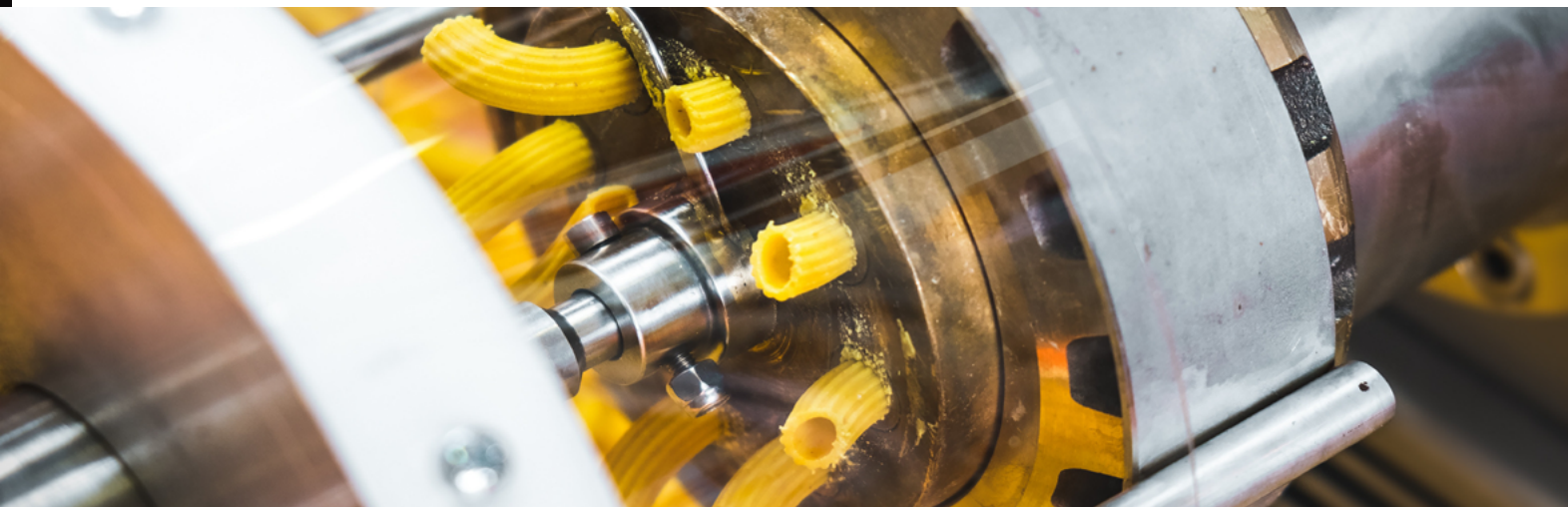















46297

# Pasta Die Guide



## Pasta Dies Visual Size Guide

 #5 Spaghetti 1.1mm	 #90 Maccheroncini 4.3mm	 #99 Maccheroni 8mm	 #105 Rigatoni 11mm
 #8 Spaghetti 1.7mm	 #251 Gigli	 #240 Fusilli 3 Wings	 #131 Fusilli 2 Wings
 #12 Spaghetti 2.5mm	 Gargati	 #386 Casarecce	 Pacchero
 Spaghetti Quadri 2.5 x 2.5mm	 #47 Reginette 9 mm	 Sfoglia 85mm - Fixed thickness	
 #59 Bucatini 3mm			
 #21 Tagliolini 1.8mm			
 #23 Tagliolini 2.6mm			
 #26 Fettuccine 6mm			
 #28 Fettuccine 9.5mm			
 #30 Pappardelle 14mm			

*Photos are not to scale*

 Fettuccine	 Tagliolini	 Macaroni	 Spaghetti	 Sfoglia 85mm	 Gargati	 Macaroni
 Spaghetti	 Fusilli	 Bucatini	 Pappardelle	 Casarecce	 Fettuccine	

## Brass Pasta Die for LP 5 (48226)

Item	Description	Item	Description	Item	Description
18917	Lasagna 85 mm	21631	#21 Tagliolini 1.8 mm	45388	#59 Bucatini 3 mm
24092	Sfoggia 85 mm	23642	#23 Tagliolini 2.6 mm	23825	#90 Maccheroncini 4.3 mm
46612	Spaghetti Quadri 2.5 x 2.5mm	39321	#26 Fettuccine 6 mm	20079	#99 Macaroni 8 mm
46114	Pacchero Liscio 25 mm	21631	#21 Tagliolini 1.8 mm	21258	#105 Rigatoni 11 mm
26084	Gargati 8 mm	23642	#23 Tagliolini 2.6 mm	22054	#131 Fusilli 2 Wings 7 mm
45386	#5 Spaghetti 1.1 mm	39321	#26 Fettuccine 6 mm	27208	#240 Fusilli 3 Wings 8.4 mm
45387	#8 Spaghetti 1.7 mm	23827	#28 Fettuccine 9.5 mm	21187	#251 Gigli Lisci 10.4 mm
42939	#12 Spaghetti 2.5 mm	19305	#30 Pappardelle 14 mm	21188	#386 Casarecce 8.8 mm
		23340	#47 Reginette 9 mm		

## Pasta Die for TR 70 (13320)

Item	Description	Item	Description	Item	Description
13321	Lasagna 160 mm	13339	#26 Fettuccine 6 mm	13355	#105 Maccheroni Rigati 11 mm
13322	#3 Spaghetti 0.8 mm	13341	#28 Fettuccine 10 mm	13356	#108 Maccheroni Rigati 15 mm
13326	#8 Spaghetti 1.7 mm	13343	#31 Pappardelle 17 mm	13357	#133 Fusilli 3 Rings 10 mm
13329	#12 Spaghetti 2.5 mm	13345	#33 Tagliatelle 25 mm	39690	#127 Tortiglione 8.8 mm
13333	#18 Linguine 3 x 1.6 mm	13346	#47 Reginette 9 mm	13358	#163 Pipe Rigate 16 mm
13334	#21 Tagliolini 1.8 mm	13347	#51 Reginette 20 mm	13359	#190 Conchiglie Rigate 28 mm
13335	Spaghetti Quadri 2.5 x 2.5 mm	13349	#59 Bucatini 3 mm	13361	#382 Gnocchetti Sardi 19 mm
13336	#23 Tagliolini 2.5 mm	13353	#90 Maccheroni Rigati 4.8mm	13363	#386 Casarecce 8.8 mm
		13354	#99 Maccheroni Rigati 8 mm	39591	Amori Pasta Die Brass

## Pasta Die for TR 75 (49118), TR 75 E (49117)

Item	Description	Item	Description	Item	Description
17127	Lasagna 180 mm	24013	#25 Tagliatelle 4.5 mm	19434	#90 Rigatoni 4.8 mm
13366	#3 Spaghetti 0.8 mm	13378	#26 Tagliatelle 6 mm	13387	#99 Rigatoni 8 mm
13369	#8 Spaghetti 1.7 mm	23766	#28 Tagliatelle 10 mm	45339	#105 Rigatoni 11 mm
19435	#9 Spaghetti 1.9 mm	24014	#31 Tagliatelle 17 mm	19756	#108 Rigatoni 15 mm
13371	#10 Spaghetti 2.1 mm	13381	#47 Reginette 9 mm	13391	#133 Fusilli 3 Rings 10 mm
13372	#12 Spaghetti 2.5 mm	13382	#51 Reginette 20 mm	13392	#163 Pipe Rigate 16 mm
13373	#16 Linguine 2.6 x 1.5 mm	31332	#57 Bucatini 2.5 mm	13393	#190 Conchiglie Rigate 28 mm
13375	#21 Tagliatelle 1.8 mm	13384	#59 Bucatini 3 mm	13395	#382 Gnocchetti Sardi 19 mm
13376	#23 Tagliatelle 2.5 mm	36517	#64 Bucatini 6 mm	19757	#386 Casarecce 8.8 mm

## Pasta Die for TR 95 (13397)

Item	Description	Item	Description	Item	Description
17129	Lasagna 230 mm	13411	#25 Tagliatelle 4.5 mm	22129	#105 Rigatoni 11 mm
13399	#3 Spaghetti 0.8 mm	13412	#26 Tagliatelle 6 mm	13426	#108 Rigatoni 15 mm
13402	#7 Spaghetti 1.5 mm	13414	#28 Tagliatelle 10 mm	13429	#133 Rotini 10 mm
13403	#8 Spaghetti 1.7 mm	13415	#31 Tagliatelle 17 mm	13431	#163 Pipe Rigate 16 mm
13404	#9 Spaghetti 1.9 mm	13416	#47 Reginette 9 mm	13434	#190 Conchiglie Rigate 28 mm
13405	#10 Spaghetti 2.1 mm	13417	#51 Reginette 20 mm	13408	#121 Penne Rigate 7 mm
13406	#12 Spaghetti 2.5 mm	13419	#57 Bucatini 2.5 mm	13436	#382 Gnocchetti Sardi 19 mm
13407	#16 Linguine 2.6 x 1.5 mm	13420	#59 Bucatini 3 mm	13437	#386 Cararecce 8.8 mm
13409	#21 Tagliatelle 1.8 mm	13422	#90 Rigatoni 4.8 mm	13439	Penne
13410	#23 Tagliatelle 2.5 mm	18945	#99 Rigatoni 8 mm		

## Pasta Die for TR 150 (13286)

Item	Description	Item	Description	Item	Description
19737	Lasagna 380 mm	13297	#25 Tagliatelle 4.5 mm	13306	#90 Rigatoni 4.8 mm
13288	#3 Spaghetti 0.8 mm	13298	#26 Tagliatelle 6 mm	13307	#99 Rigatoni 8 mm
13289	#7 Spaghetti 1.5 mm	13299	#28 Tagliatelle 10 mm	13309	#105 Rigatoni 11 mm
13290	#8 Spaghetti 1.7 mm	13300	#31 Tagliatelle 17 mm	13310	#108 Rigatoni 15 mm
13291	#9 Spaghetti 1.9 mm	13301	#47 Reginette 9 mm	13311	#133 Fusilli 3 Rings 10 mm
13308	#10 Spaghetti 2.1 mm	13302	#51 Reginette 20 mm	13312	#163 Pipe Rigate 16 mm
13292	#12 Spaghetti 2.5 mm	13303	#57 Bucatini 2.5 mm	13313	#190 Conchiglie Rigate 28 mm
13293	#16 Linguine 2.6 x 1.5 mm	13304	#59 Bucatini 3 mm	13314	#382 Gnocchetti Sardi 19 mm
13294	#17 Linguine 2.9mm	13305	#64 Bucatini 6 mm	13315	#386 Casarecce 8.8 mm
13295	#21 Tagliatelle 1.8 mm				
13296	#23 Tagliatelle 2.5 mm				

## Pasta Die for TR 100 (16643/13236), TRD 100 (13440)

Item	Description	Item	Description	Item	Description
17132	Lasagna 280 mm	13251	#23 Tagliatelle 2.5 mm	13265	#99 Rigatoni 8 mm
13238	#3 Spaghetti 0.8 mm	24212	#25 Tagliatelle 4.5 mm	13266	#105 Rigatoni 11 mm
24086	#3 Spaghetti 0.8 mm*	13253	#26 Tagliatelle 6 mm	20209	#108 Rigatoni 15 mm
13241	#7 Spaghetti 1.5 mm	23719	#28 Fettuccine 9.5 mm	45915	#128 Tortiglioni 13 mm
31806	#8 Spaghetti 1.7 mm	13255	#31 Tagliatelle 17 mm	24213	#133 Fusilli 3 Rings 10 mm
19437	#9 Spaghetti 1.9 mm	13256	#47 Reginette 9 mm	13274	#163 Pipe Rigate 16 mm
13244	#10 Spaghetti 2.1 mm	19436	#51 Reginette 20 mm	24214	#190 Conchiglie Rigate 28 mm
24490	#12 Spaghetti 2.5 mm	13258	#57 Bucatini 2.5 mm	45532	#252 Gigli Festonati 11.4 mm
13247	#16 Linguine 2.6 x 1.5 mm	13259	#59 Bucatini 3 mm	20445	#382 Gnocchetti Sardi 19 mm
13248	#18 Linguine 3 x 1.6 mm	13260	#64 Bucatini 6 mm	13284	#386 Casarecce 8.8 mm
13250	#21 Tagliatelle 1.8 mm	13263	#90 Rigatoni 4.8 mm	13285	#116 Penne Lisce 6 mm

For complete listing please visit [WWW.TRENTOEQUIPMENT.COM](http://WWW.TRENTOEQUIPMENT.COM)



Standard dies come in different configurations. Custom sizes to be ordered. Extra lead times required.

# Food Preservation

Cheese Seasoning	121
Fish Curing & Smoking	123
Meat Curing & Aging	129
Salami Curing	143
Vacuum Packing	151

# 05



# Cheese Drying & Seasoning

# Affinacheese®

(Optional Installation, Setup and product training available upon request)

\*Shipped on Pallet

## Drying or seasoning all types of cheeses



### 220 lb Capacity

### 330 lb Capacity

### 440 lb Capacity (220+ 220)

#### FEATURES

- Smooth Guide Sets
- Polypropylene Shelves
- Drain Tray
- Flexible Drain Hose
- Fumotic®
- Air Exchange Kit
- Water Filter
- 2 Tanks Water/Aroma
- 4 Adjustable Legs

#### OPTIONAL ITEMS:

- Hanging Rods
- Wall Mount Kit
- PH Probe
- HACCP Data Printer



45517



45518



45516



45519



45520

### 132 lb Capacity

### 440 lb Capacity

Item	45517	45518
Model	STGPNSTF6	STG100TFO
Capacity	132 lb (60 kg)	220 lb (100 kg)
Working Temperature	10 - 32°C (50- 89.6°F)	10 - 32°C (50- 89.6°F)
Electrical	220V / 60Hz / 1Ph	220V / 60Hz / 1Ph
Net Weight	467 lb (212 kg)	507 lb (230 kg)
Net Dimensions (WDH)	43" x 31" x 53"	43" x 31" x 85"

Item	45516	45519	45520
Model	STG150TFO	STG200TFO	STGTWITFO
Capacity	330 lb (150 kg)	440 lb (200 kg)	220 + 220 lb (100 + 100 kg)
Working Temperature	10 - 32°C (50- 89.6°F)	10 - 32°C (50- 89.6°F)	10 - 32°C (50- 89.6°F)
Electrical	220V / 60Hz / 1Ph	220V / 60Hz / 1Ph	220V / 60Hz / 1Ph
Net Weight	617 lb (280 kg)	805 lb (365 kg)	551 lb (250 kg)
Net Dimensions (WDH)	35" x 31" x 83"	57" x 31" x 87"	57.6" x 30.9" x 83.2"

# Fish Curing & Smoking



(Optional Installation, Setup and product training available upon request)

Discover the 'Intelligent' System for curing, cooking, and smoking fish



Stagionello® fish curing device is the unique cabinet for dry aging fish with a controlled pH system for the smoking and curing of sea salami and for cooked Tuna and Squid Mortadella. It has been designed, manufactured and patented 100% made in Italy.

With the introduction of dry aged, smoked fish and cured fish salami, the quality and flavors amplify the most refined palates. Clients aim to get the freshest and best-preserved products and display it in the best way possible to attract the attention of customers.

These cabinets and walk in cold rooms are built entirely of AISI 304 stainless steel with a scotch-brite finish both internally and externally to protect food contact and contamination. The cabinets can be incorporated into furnishings or walls.

The doors are completely in AISI 304 stainless steel; all have a large double-glazed glass with UV protection and are equipped with lock and key to allow use both in the laboratory and in the sales area. The large glass on the door allows you to monitor product on sight and in the sales area and is consequently an attractive Italian design display showcase. The four extendable stainless steel legs allow perfect stability. The exterior can be customized from a wide range of colors and coatings by our skilled Italian craftsmen.

These are just some of the features that make the unique patented Pesciugatore® and its range of cabinets guaranteed to be the most copied in the world!

\*Shipped on Pallet

## 132 lb Capacity

### FEATURES

- Display 7" S.F.C.
- Integrated pH system
- Cleaning in place
- Remote Control
- 4 AISI 304 stainless steel grills
- 4 sets of AISI 304 stainless steel guides
- 2 glass door
- Humidification/Aromatization system
- Hot gas defrosting system
- Automatic interior LED lighting
- Air exchange kit
- Humidity range: 30% - 99%



Item	49001
Model	PES0604.0
Maturing Capacity	132 lb (60 kg)
Number of Doors	2 Glass Swing Doors
Number of Shelves	4 grills/rack 4 guides set
Temperature Range	0 to 35 °C (32 to 95°F)
Relative Humidity Range	30% - 99%
Power	2376 W
Amps	10.8 A
Electrical	220V / 60Hz / 1Ph
Weight	330 lb (150 kg)
Dimensions	43.3" x 30.9" x 53.1"

## 220 lb Capacity



49002

## 330 lb Capacity



49003

## 440 lb Capacity



49004

## 440 lb Capacity (220 + 220)



49005

- Display 7" S.F.C.
- Integrated pH system
- Cleaning in place
- Remote Control
- 7+7 AISI 304 stainless steel grills
- 2 Glass Doors

- Humidification/Aromatization system
- Hot gas defrosting system
- Automatic interior LED lighting
- Air Exchange Kit
- Humidity Range: 30% - 99%

	220 lb (100 kg) Capacity	330 lb (150 kg) Capacity
Item	49002	49003
Model	PES1004.0	PES1504.0
Maturing Capacity	220 lb (100 kg)	330 lb (150 kg)
Number of Doors	1 Glass Swing Door	1 Glass Swing Door
Number of Shelves	7 grill / rack with 7 guide sets	
Power	2,376 W	3,500 W
Amps	10.8 A	14.4 A
Electrical	220V / 60Hz / 1Ph	
Temperature Range	0 to 35 °C (32 to 95°F)	
Relative Humidity Range	30% - 99%	30% - 99%
Weight	474 lb (215 kg)	474 lb (215 kg)
Dimensions	28.7" x 30.9" x 86.7"	35.6" x 30.9" x 86.6"

- Display 7" S.F.C.
- Integrated pH system
- Cleaning in place
- Remote Control
- 7 AISI 304 stainless steel grills
- 7 sets of AISI 304 stainless steel guides
- 1 Glass Door
- Humidification/Aromatization system
- Hot gas defrosting system
- Automatic interior LED lighting
- Air Exchange Kit

	440 lb (200 kg) Capacity	220+220 lb (100 +100 kg) Capacity
Item	49004	49005
Model	PES2004.0	PESTW14.0
Maturing Capacity	440 lb (200 kg)	220 + 220 lb (100 + 100 kg)
Number of Doors	2 Glass Swing Doors	2 Glass Swing Doors
Number of Shelves	14 grills/racks with 14 guide sets	
Power	4,140 W	3,700 W
Amps	17.3A	14.4 A
Electrical	220V / 60Hz / 1Ph	
Temperature Range	0 - 35°C (32 - 95°F)	
Relative Humidity Range	30% - 99%	30% - 99%
Weight	551 lb (250 kg)	474 lb (215 kg)
Dimensions	57.7" x 30.9" x 86.6"	57.7" x 30.9" x 86.6"

THE ALL NEW SERIES

# Stagionello® Dry-Age 3.0: The World's First Patented Dry-Aging Cabinet

With pH indicator for professional dry-aging of meat,  
fish, and seafood, intended to naturally preserve fresh  
or dry-aged goods for an extended period.

TRENTO

Stagionello®



# Meat Curing & Aging

# Stagionello®

MEAT MATURING DEVICE

Produce prime quality meat!  
as little as **11** days!



Stagionello® meat maturing device is the only maturation cabinet guaranteed, patented and manufactured 100% in Italy that reproduces a series of micro-climates ideal for the traditional maturation of meat (dry aged). In as little as eleven days our system allows you to transform your meat into tender, juicy steaks, safely. This is equipped with an industrial refrigeration system (not mono-block).

Thanks to the patented Fumotic® system, it ensures the production and management of humidity used to reduce the weight loss of the meat. In addition, since the user can smoke/avor the product at low temperatures, without any combustion, it safely keeps the organoleptic properties of the meat unchanged.

Unlike wet aging, where the meat from its vacuum-sealed bag must be consumed immediate after opening, allows you to hang, store and consume meat in a longer period of time without similar risks. The unit is equipped with an advanced touch screen controller, that automatically manages the temperature, humidity, air speed, pH monitoring, smoke/avoring for the duration of the recipe.

The Climatouch® controller, built into this device, allows you to quickly start your next recipe, monitor recipe values, create and save new recipes, calibrate the pH probe and review HACCP data. These features and more make it one of a kind.



- Made in Stainless Steel AISI 304
  - Climatouch® - A revolutionary automatic control system with a 6-inch touch screen display that automatically manages all sequential processing stages, calculating pH levels during the fermentation process guaranteeing a quality product. It includes preset recipes and allows the user to have access to the system which controls the functionality of the unit
  - Fumotic® - This is a dual purpose system for regulating humidity and flavoring
  - Energy Efficient: The AISI 304 Stainless Steel body and doors are fully injected with CFC free polyurethane foam creating a uni-body frame and higher R-value
  - Professional grade Non Mono-block system: Our non mono-block system is comprised of various components specially designed with the capability to be used for seasoning and dry aging, and can function in an ambient temperature range for up to +32°C (89.6°F)
  - There are a number of alarms built into the system for protection
  - Equipped with a lock and key system for additional safety
  - 4 standard probes included in all units
  - The tank system is designed to work with the Fumotic® to provide humidity when needed and aroma flavor as desired by the user
  - The doors are designed and built in AISI 304 stainless steel, dual insulated glass panels with UV protection of 59%, pressure valve for high altitudes, resistance lines to minimize condensation and soften door seals at lower temperatures.
  - Pre-Calibrated pH Probe included
- Special order: Custom colors available (Call upon request)  
• Optional installation, setup and product training available upon request

# Stagionello Technology

Technology	Maturmeat 4.0	Dry Age 3.0	Primeat 2.0
Brand			
Product Image (not to scale)			
Features	<ul style="list-style-type: none"> <li>• Aerobic Maturation</li> <li>• Drying</li> <li>• Fermentation</li> <li>• Cooking Option</li> <li>• Flavored Smoking</li> <li>• Preservation</li> <li>• Weight Loss Management</li> <li>• Analysis, Verification and Management of pH</li> </ul>	<ul style="list-style-type: none"> <li>• Drying</li> <li>• Preservation</li> <li>• Weight Loss Management</li> <li>• Reading and Monitoring of pH</li> </ul>	<ul style="list-style-type: none"> <li>• Drying</li> <li>• Preservation</li> </ul>
Control System	Food Control 7" Color - Touch Screen Remote Data Connection	Dry Age Control 4.3" Color - Touch Screen	Dry Age Control 4.3" Color - Touch Screen
Patented Device	✓	✓	✓
License to Use Maturation Method	✓	✗	✗
Validated Shelf Life	6 Months	✗	✗
PH-Metric System	Analysis, Meat pH Management - Min-Max Alarm - HACCP Register	Reading - Min-Max Alarm - HACCP Register	✗
Humidification System	✓ Direct or Tank Connection	✓ Direct or Tank Connection	✓
Weight Loss Management	✓	✓	✗
Cold Flavored Smoking System	✓ Tank 5 LT.	✗	✗
Ventilation	Automatic and/or Adjustable	Automatic and/or Adjustable	Adjustable
Air Treatment Unit (Interior)	Stainless Steel AISI 304	Stainless Steel AISI 304	Stainless Steel AISI 304
HACCP Register	✓	✓ (2 Register)	✓
C.I.P. Cleaning in Place (Automatic and Integrated Washing and Sanification System)	✓	✗	✗
Operational Procedures and Process Validation	✓	✗	✗
Personal Training Course	✓	✗	✗
Compliant with Future European Guidelines (EFSA)	✓	✓	✓
MOCA Certification	✓	✓	✓
QPS + CE Certification	✓	✓	✓

- E.F.S.A. Dry Age Compliance up to 35 Days (European Food Safety Authority)
- EU Dry-Age Compliant System PATENT N. 276878
- Internal Structure in AISI 304 Stainless Steel as Standard
- Energy-Saving Efficient System
- Zero Installation Costs thanks to "Plug & Dry" System
- pH Reading, Monitoring and Alarms
- U.T.A. Air Treatment Unit in AISI 304 Stainless Steel - No Polystyrene
- Real Humidity Management with Umiright®
- Drop-Weight Management Systems as Standard
- Tank or Direct Water Connection
- Reduces Waste
- FCM Certificate (Materials Suitable for Contact with Food)

- 100% Italian made,
- 100% built of Stainless Steel AISI 304,
- Superior quality, and provide a tool for the authentic dry-aging of meat and fish

Choosing Stagionello® Dry-Age 3.0 cabinets means relying on the "friendly user" intelligence of Dry-Age control 3.0, the translation of professional dry-aging technology! Two distinct devices, each tailored to the qualities of fresh or matured meat and fish, to ensure excellent and consistent Dry-Age drying.

10 climatic recipes to make - 5 different dry-aging process, and 5 different fresh meat preservation.

4 scientifically validated preset recipes dedicated to beef, pig, sheep/goat, and wild meat. 1 custom recipe for creating your own Dry-Age program by customizing the time, temperature, humidity, and ventilation! Quality is guaranteed due to the distinctive proprietary methods found on all Stagionello® Dry-Age 3.0 systems. 2 HACCP System for Best Analysis

Stagionello® is concerned about food safety and provides experts with a specialized dual verification system for standard and unique recipes, logging temperature, humidity, and pH by event date and time. Everything is available at all times on a designated screen that can be viewed online.

### Eco-Friendly System

- 20% less energy - This modern technology guarantees high performance with 20% less energy than similar systems on the market.
- Eco Sustainable - Stagionello® reduces the use of plastic on all devices in support of greater environmental sustainability.
- Less Waste - By increasing the shelf life of food up to 30 days with the Dry-Age process, we jointly promote the reduction of food waste for the benefit of the environment, the economy and the well-being of people.

## Primeat 2.0 176 lb Capacity

\*Shipped on Pallet



### FEATURES

- ClimaTouch® Lite is the patented control system with:
  - \* 4 recipes for dry aged meats
  - \* 4 recipes for fresh meats
  - \* 1 customizable micro-climatic recipe (up to 5 steps)
  - \* HACCP data log
- Alarms log
- ClimaCure® with a series of high-quality sensors able to control & managed
- DynaFlow® the indirect & adjustable ventilation system
- HumiRight® for proper humidification & dehumidification
- LED lighting
- 4 shelves made of AISI 304 stainless steel



Item	47117
Model	DRY 80
Capacity	176 lb (80 kg)
Number of Doors	1 Swing Door
Number of Shelves	4 Grills/Shelves
Power	510 W
Amps	4.4 A
Electrical	115V / 60Hz / 1Ph
Temperature Range	-2 - 10°C / 28.4 - 50°F
Humidity Range	20% - 92% U.R.
Net Weight	183 lb (83 kg)
Net Dimensions (WDH)	23.6" x 23.6" x 78"

## Stagionello 2.0 264 lb Capacity



Item	48036
Model	PI2AION04STS
Capacity	264 lb (120 kg)
Number of Doors	1 Swing Door
Number of Shelves	4 Grills/Shelves
Power	550 W
Amps	3.4 A
Electrical	115V / 60Hz / 1Ph
Temperature Range	-3 - 10°C / 26.6 - 50°F
Humidity Range	30% - 90% U.R.
Net Weight	190 lb (86 kg)
Net Dimensions (WDH)	23.6" x 23.6" x 78"

DRY-AGED MEAT AND FISH SAFELY UP TO 35 DAYS!

## Simple, Safe and Intuitive Dry Age Control 3.0

Multi-functional display cabinets that are intended to naturally preserve fresh or Dry-Aged goods for an extended period of time.

To improve professionals' experience, an attractive and elegant design is offered in three different capacities and three distinct display versions. The revolutionary drop-weight management systems and unique pH detection and monitoring function of Stagionello Dry-Age 3.0 allow for continuous food-safe chilling, drying, and storage of meat and fish.



Stagionello Dry Age 3.0 produces  
**NO WASTE, NO MOLD, NO UNWANTED ODOURS**

**Umiright®**

The specialized moisture management system that ensures higher quality for longer, resulting in less waste and more profit, can also be used to monitor weight loss.

**Dynaflow®**

Ensures a healthy and safe environment by managing thermodynamics and air speed to guarantee optimal aeration for improved food preservation.

**Dry Age 3.0 496 lb Capacity**



**Dry Age 3.0 330 lb Capacity**



	Standard (1-Glass View)	2-Glass View	4-Glass View
Item	48037	48038	48039
Model	PI3AION07STI	PI3AION07TTI	PI3AION074VI
Capacity	24.7 cu.ft. (700 L)		
Material Interior	Stainless Steel AISI 304		
Material Exterior	Stainless Steel AISI 304 or painted sheet metal		
Number of Doors	1 Glass Door - Swing Door		
Number of Shelves	4		
Shelf Capacity	77 lb (35 kg)		
Power	Max 1730 W - rated 548 W		
Amps	Max 8.0 A - rated 1.9 A		
Electrical	220-240V / 60Hz / 1Ph		
Sterilization	Self-sterilization by the operator		
Working Temperature	-3 - 35°C (26.6 - 95°F)		
Relative Humidity Range	30 - 99% RH		
Interior Dimensions (WDH)	24.4" x 26.4" x 63"		
Net Weight	496 lb (225 kg)	547 lb (248 kg)	463 lb (210 kg)
Net Dimensions (WDH)	28.7" x 31" x 83"		

	Standard (1-Glass View)	2-Glass View	4-Glass View
Item	48040	48041	48042
Model	PI3AION09STI	PI3AION09TTI	PI3AION094VI
Capacity	31.8 cu.ft. (900 L)		
Material Interior	Stainless Steel AISI 304		
Material Exterior	Stainless Steel AISI 304 or painted sheet metal		
Number of Doors	1 Glass Door - Swing Door		
Number of Shelves	4		
Shelf Capacity	77 lb (35 kg)		
Power	Max 2960 W - rated 980 W		
Amps	Max 13.4 A - rated 4.8 A		
Electrical	220-240V / 60Hz / 1Ph		
Sterilization	Self-sterilization by the operator		
Working Temperature	-3 - 35°C (26.6 - 95°F)		
Relative Humidity Range	30 - 99% RH		
Interior Dimensions (WDH)	31.5" x 26" x 63"		
Net Weight	573 lb (260 kg)	639 lb (290 kg)	529 lb (240 kg)
Net Dimensions (WDH)	28.7" x 30.9" x 83.2"		

## Dry Age 3.0 **992 lb Capacity** (Single Cabinet)



	Standard (1-Glass View)	2-Glass View	4-Glass View
Item	48043	48044	48045
Model	PI3AION14STI	PI3AION14TTI	PI3AION144VI
Capacity	49.5 cu.ft. (1400 L)		
Material Interior	Stainless Steel AISI 304		
Material Exterior	Stainless Steel AISI 304 or painted sheet metal		
Number of Doors	2 Glass Doors - Swing Door		
Number of Shelves	4+4		
Shelf Capacity	77 lb (35 kg)		
Power	Max 2960 W - rated 980 W		
Amps	Max 13.4 A - rated 4.8 A		
Electrical	220-240V / 60Hz / 1Ph		
Sterilization	Self-sterilization by the operator		
Working Temperature	-3 - 35°C (26.6 - 95°F)		
Relative Humidity Range	30 - 99% RH		
Interior Dimensions (WDH)	53" x 26" x 63"		
Net Weight	782.6 lb (355kg)	826.7 lb (375 kg)	738.5 lb (335 kg)
Net Dimensions (WDH)	57.6" x 34.5" x 83.2"		



## Dry Age 3.0 992 lb Capacity (Twin Cabinet)



	Standard (1-Glass View)	2-Glass View	4-Glass View
Item	48046	48047	48048
Model	PI3AIONTWSTI	PI3AIONTWTTI	PI3AIONTW4VI
Capacity	49.5 cu.ft. (1400 L)		
Material Interior	Stainless Steel AISI 304		
Material Exterior	Stainless Steel AISI 304 or painted sheet metal		
Number of Doors	2 Glass Doors - Swing Door		
Number of Shelves	4+4		
Shelf Capacity	77 lb (35 kg)		
Power	Max 3500 W - rated 1300 W		
Amps	Max 15.0 A - 5.9 A		
Electrical	220-240V / 60Hz / 1Ph		
Sterilization	Self-sterilization by the operator		
Working Temperature	-3 - 35°C (26.6 - 95°F)		
Relative Humidity Range	30 - 99% RH		
Interior Dimensions (WDH)	two - 22.4" x 26 x 63"		
Net Weight	881 lb (395 kg)	937 lb (425 kg)	804.7 lb (365 kg)
Net Dimensions (WDH)	57.6" x 34.5" x 83.2"		





45143



40345



40299

## 132 lb - 330 lb Capacity Maturmeat 4.0



	132 lb (60 kg) Capacity	220 lb (100 kg) Capacity	330 lb (150kg) Capacity Silver	330 lb (150kg) Capacity Black
Item	45143*	40345*	40299*	46184*
Model	MAT0604.0	MAT1004.0_INOX	MAT1504.0	MAT150V40-BLACK
Capacity	132 lb (60 kg)	220 lb (100 kg)	330 lb (150kg) Dual internal fans & air exchange kit included	
Number of Shelves	2+2 Guide sets / 2+2 stainless steel shelves	5 Guide sets / 5 stainless steel shelves	5 Guide sets / 5 stainless steel shelves	
Working Temperature	10 - 32°C (50- 89.6°F)			
Ambient Relative Humidity	Less than 90% RH			
Rated Power	2,376 W	748 W	3,500 W	
Rated Current	10.8 A	3.4 A	14.4 A	
Electrical	220V / 60Hz / 1Ph	220-240V/60Hz/1Ph		
Internal Memory	352 Kb Ram (approx.100 recipes)			
Net Weight	467 lb (212 kg)	463 lb (210 kg)	573 lb (260 kg)	
Net Dimensions (WDH)	31" x 43" x 33"	28.74" x 30.7" x 88.5"	39" x 33" x 86"	



44187



45176

## 440 lb - 882 lb Capacity Maturmeat 4.0



	440 lb (200 kg) Capacity	220 lb (100 + 100kg) Capacity	882 lb (400kg)
Item	41187	45176*	45344
Model	MAT2004.0_INOX	MATTWI4.0	MAT4004.0
Description	440 lb (200 kg)	220 lb (100 + 100kg)	882 lb (400kg) Air exchange kit included
Number of Shelves	10 Guide sets / 10 stainless steel shelves	5+5 Guide sets / 5+5 stainless steel shelves	15 Guide sets / 15 stainless steel shelves
Working Temperature	- 5 to 50°C (23 to 122°F)		
Ambient Relative Humidity	Less than 90% RH		
Power	4,140 W	3,700 W	5,150 W
Amps	18 A	17 A	23 A
Electrical	220V / 60Hz / 1Ph		220V / 60Hz / 3Ph
Internal Memory	352 Kb Ram (approx.100 recipes)		
Net Weight	805 lb (365 kg)		970 lb (400 kg)
Net Dimensions (WDH)	57" x 31" x 85"	57" x 31" x 85"	100" x 37" x 101"

# Salami Curing



Produce salami as little as **20** days!



Stagionello® is the original and the first unit to create a series of micro-climates ideal for traditional salami processing. On an average of only 20 days, Stagionello® can help you produce genuine meats without the need for chemical additives, such as colorants.

The commercial grade system (non mono-block) allows for the optimal temperature in a short period time. Temperature is then maintained thanks to the unified structure of high-density, high compression, non-toxic polyurethane foam thermal insulation.

Stagionello®, combined with Fumotic®, is able to produce and manage humidity, cold smoke and or flavor the product inside the chamber. Like the Stagionello®Evo, the control system automatically manages the temperature, humidity and air speed for the duration of the programmed phases: salting, stewing, smoking / aromatization, drying and seasoning. Stagionello® is made of AISI 304 stainless steel with a

scotch-brite finish, both internally and externally where in contact with food. The stainless steel door (not aluminum) has a large glass panel with the key/lock system, so as to allow the use both in the kitchen/laboratory or in a retail area.

In the laboratory, the large glass panel allows you to monitor the transformation process, in a retail area it can be used as a showcase to cure and display simultaneously. The four adjustable stainless steel legs allow for perfect stability.

Optionally, the exterior can also be customized by choosing from a wide range of colors. These are just some of the features that gave our technology worldwide status, making us the most copied food transformation technology in recent history.





**60kg** STG0604.0 44954  
**100kg** STG1004.0\_INOX 41474  
**200kg** STG2004.0 45232  
**100kg+100kg** STGTWI4.0 41262  
**100+300kg** STG10304.0 45485  
**200+600kg** STG2064.0 45487  
**StagionelloEvo®150kg**  
**(Silver)** STG1504.0\_INX / 40298  
**(Red)** STG150V40-RED / 46183  
**(Black)** \*SPECIAL ORDER

- Made in Stainless Steel AISI 304
- Climatouch® - A revolutionary automatic control system with a 6-inch touch screen display that automatically manages all sequential processing stages, calculating pH levels during the fermentation process guaranteeing a quality product. It includes preset recipes and allows the user to have access to the system which controls the functionality of the unit
- Fumotic® - This is a dual purpose system for regulating humidity and flavoring
- Energy Efficient: The AISI 304 Stainless Steel body and doors are fully injected with CFC free polyurethane foam creating a uni-body frame and higher R-value
- Professional grade Non Mono-block system: Our non mono-block system is comprised of various components specially designed with the capability to be used for seasoning and dry aging, and can function in an ambient temperature range for up to +32°C (89.6°F)
- There are a number of alarms built into the system to protect the Stagionello®
- Equipped with a lock and key system for additional safety
- 4 standard probes included in all Stagionello® units
- The tank system is designed to work with the Fumotic® to provide humidity when needed and aroma flavor as desired by the user
- The doors are designed and built in AISI 304 stainless steel, dual insulated glass panels with UV protection of 59%, pressure valve for high altitudes, resistance lines to minimize condensation and soften door seals at lower temperatures.
- Pre-Calibrated pH Probe included
- Ambient Relative Humidity is less than 90% RH

- \*Special order: Custom colors available (Call upon request)
- Optional Installation, setup and product training available upon request

## StagionelloEvo



	132lb (60kg) Capacity	220lb (100kg) Capacity	331lb (150kg) Capacity Silver	331lb (150kg) Capacity Red
Item	44954*	41474*	40298*	46183*
Model	STG0604.0	STG1004.0_INOX	STG1504.0_INX	STG150V40-RED
Capacity	132lb (60kg)	220lb (100kg)	331lb (150kg)	
Number of Doors	2 Swing Glass Doors	1 Swing Glass Door	1 Swing Glass Door	
Number of Shelves	2+2 Guide sets / 10+10 stainless steel hanging rods	4 Guide sets / 20 stainless steel hanging rods		
Power	2,600 W			
Amps	11 A			
Electrical	220V / 60Hz / 1Ph			
Working Temperature	-5 to 50 °C (23 to 122°F)			
Internal Memory	352 Kb Ram (approx.100 recipes)			
Net Weight	330 lb (150 kg)	308 lb (140 kg)	617 lb (280 kg)	
Net Dimensions	43.3" x 30.7" x 52.75"	33" x 33" x 86"	35" x 31" x 85"	

## StagionelloEvo

	220 lb + 220lb (100kg + 100kg) Capacity	441 lb (200kg) Capacity
Item	41262*	45232
Model	STGTWI4.0	
Capacity	220 lb + 220lb (100kg + 100kg)	441 lb (200kg)
Number of Doors	2 Swing Glass Doors	
Number of Shelves	4+4 Guide sets / 20+20 stainless steel hanging rods	
Working Temperature	-5 to 50 °C (23 to 122°F)	
Power	3,200 W	4,190 W
Amps	12 A	
Electrical	220V / 60Hz / 1Ph	
Internal Memory	352 Kb Ram (approx.100 recipes)	
Net Weight	805 lb (365 kg)	805 lb (440 kg)
Net Dimensions	57" x 31" x 85"	57" x 31" x 85"

## Stagionello

	220 + 661 lb (100 + 300 kg) cabinet	441 + 1322 lb (200 + 600kg) cabinet
Item	45485*	45487
Model	STG10304.0	STG2064.0
Capacity	220 + 661 lb (100 + 300 kg) cabinet	441 + 1322 lb (200 + 600kg) cabinet
Number of Doors	3 Swing Glass Doors	
Number of Shelves	5+5+5	
Working Temperature	-5 to 50 °C (23 to 122°F)	
Power	7,120 W	8,600 W
Amps	10.32 A	12.5 A
Electrical	220V / 60Hz / 3 Ph+N	220V / 60Hz / 3Ph
Internal Memory	352 Kb Ram (approx.100 recipes)	
Net Dimensions	100" x 37" x 102"	100" x 69" x 102"

Automatic internal lighting, dehumidifier, air exchange, heated frame, hot gas defrost, and industrial refrigeration unit.

## Combination **440 lb** Capacity (220+220)



### Front + Back Windows

Item	45376
Model	STGTWCV40
Description	Stagionello® Meat and Fish Curing
Interior	4+5 stainless steel guide sets / 20 stainless steel salami rods / 5 stainless steel racks
Working Temperature	-5°C to 50°C (23°F to 122°F)
Power	3,700W
Amps	3.4 A x 2
Electrical	220V / 60Hz / 1Ph
Internal Memory	352 Kb Ram (approx.100 recipes)
Net Weight	551 lb (250 kg)
Net Dimensions (WDH)	58" x 31" x 83"

### Front Windows

Item	44989
Model	STGTWC4.0
Description	Stagionello® Meat and Fish Curing
Interior	4+5 stainless steel guide sets / 20 stainless steel salami rods / 5 stainless steel racks
Working Temperature	-5°C to 50°C / 23°F to 122°F
Power	3,700W
Amps	3.4 A x 2
Electrical	220V / 60Hz / 1Ph
Internal Memory	352 Kb Ram (approx.100 recipes)
Net Weight	551 lb (250 kg)
Net Dimensions	58" x 31" x 83"
Optional	Item 41263: PH probe



# Accessories



Leg/Foot Stand

Skirting Board

Wheel Kit

Item	Stand Type	4.0 Tech Items	3.0 Tech Items	2.0 Tech Items
66047	Leg/Foot Stand			
48445	Skirting Board 100 KG/700 L	44989, 45376, 45143, 40345, 40299, 46184, 41187, 45344,	48045, 48043, 48044, 48048, 48046,	
48147	Skirting Board 150 KG/900 L	45176, 49001, 49002, 49003, 49004, 49005, 41262, 44954,	48047, 48039, 48037, 48038, 48042, 48040, 48041	47117
48446	Skirting Board Twin Combo	45487, 41474, 46183, 40298, 45232, 45485		
41264	Wheel Kit			

# Curing Salts and Spice Blends

## Fish

Item	47531	47532	47533
Model	CCONCSALMAF	ACSPAAF240	ACTONAF240
Description	For Salmon 2kg / bag	For Sword Fish 2kg / bag	For Tuna Fish 2kg / bag
Meat Quantity	22 lb (10 kg)	22 lb (10 kg)	22 lb (10 kg)
Weight	4.4 lb (2 kg)	4.4 lb (2 kg)	4.4 lb (2 kg)
Quantity/Case (pcs)	2 kg / bag	2 kg / bag	2 kg / bag



## Salami

Item	Description
47007	For Cooked Salami Mortadella 2kg / bag
47008	For Cured Salami Rapid Fermentation 1.85 kg / bag
47009	For Cured Salami Long Fermentation 1.85 kg / bag



## Rapid Ferment

Item	Description
47002	Felino 2kg / bag
47003	Hungarian 2kg / bag
47004	Calabrese 2kg / bag
47005	Cacciatore 2kg / bag



## Long Ferment

Item	Description
47000	Speck 2kg / bag
47001	Pancetta 2kg / bag



## Natural Liquid Aromas

Item	Description
47010	Barbecue Flavor 5 kg / bag
47011	Smoke Flavor 5 kg / bag



# Vacuum Packaging



## Light Duty Vacuum Packaging Machine



- Included in the package: 20 bags 7 7/8" x 11 13/16"
- LED displaying vacuum level
- 12 3/4" seal bar with continuous duty
- Power cord storing compartment
- Max. vacuum level: 830 mbar
- **Embossed bags** (Sold separately) to be used

These vacuum packaging machines are ideal for a variety of applications. The machines are equipped with a digital control panel that controls the sealing power. Once the lid is closed, the machine is ready for automatic or manual operation (if programmed).



Item	21623
Model	VP-IT-0324
Seal Bar	12 3/4"
Power	250 W
Electrical	110V / 60Hz / 1Ph
Net Weight	7 lb (3.18 kg)
Net Dimensions (WDH)	6.5" x 14.8" x 4.25"

# Automatic Heavy Duty Vacuum Packaging Machine



Item	47718
Model	VP-IT-0300
Seal Bar	11.8" (300mm)
Pump	2.4 m3/h
Power	280 W
Electrical	110-120V / 60Hz / 1Ph
Net Weight	11.5 lb (5.2 kg)
Net Dimensions (WDH)	15.4" x 10.8" x 4.9" (390 x 275 x 125 mm)

# Vertical Vacuum Packaging Machine



- Ideal for high demand residential and light duty commercial application
- Strong pump and professional seal ensure a long storage life for the packaged products
- Sealing is electronically timed and is adjustable
- Body is constructed of high-density plastic for easy cleaning
- **Embossed** bags (Sold separately) to be used with this unit
- Patented design allows side panel to be removed without tools for cleaning

Item	48246
Model	VP-IT-0005
Seal Bar	12.25" (311mm)
Pump	5 m3/h
Power	850 W
Amps	7A
Electrical	110-120V / 60Hz / 1Ph
Net Weight	10 lb (4.55 kg)
Net Dimensions (WDH)	14.5" x 12" x 6"





## Redefining the benchmark for vacuum packaging machines.

Turbovac offers a full range of vacuum packaging machines: reliable, robust, and easy to service and maintain. Turbovac recently redesigned its complete range of vacuum packaging machines and made them even easier to operate and clean. The full range of machines and available options makes it easy to select exactly the right solution for your packaging needs.

All models have hygienic easy-to-clean vacuum chambers and easily removable seal beams and silicon bars. An intuitive digital control unit can automatically detect the optimum vacuum level for each product. And for products with a high moisture content, the control unit retains exactly the right amount of moisture. This improves the tenderness and flavour of the products. With an ingenious redesign focusing on functionality, Turbovac is now setting the standard for quality and design in the industry.



### Busch Vacuum Solutions

- Decades of Experience
- Leading Supplier of Vacuum Systems
- German engineering & Quality
- Reliable & Efficient
- Up to 50% Energy Savings
- Low Maintenance & High Lifespan
- Reduced Carbon Footprint

### Trenn Seal (Optional on Select Models):

With a "trenn seal" one wire will seal the bag and the other heating wire will almost melt off the remainder of the bag. By pulling the remainder off the package, it will have a nicer appearance. Also possible product that might be left in the remaining plastic is removed for better hygiene.



## Digital control unit with LCD display

For our new line of machines, the control unit is completely redesigned.

Simplicity was the starting point.

OPTIONAL FEATURES (For 10 program machines)

## Modified Atmospheric Packaging

### (M.A.P - Gas flush)

Some products cannot be packaged under vacuum but may better packaged by replacing the air by a mix of gases, like the Inert gas Nitrogen (N<sub>2</sub>), Carbon-dioxide (Co<sub>2</sub>) or Oxygen (O<sub>2</sub>) to increase shelf life and appearance.

## Sensor/ Time control

With a sensor controlled machine the vacuum is measured using a sensor with very high accuracy and the results are digitally displayed.

With a time controlled vacuum machine, a timer is set and the vacuum level can be monitored with an analogue vacuum-meter.

## Soft Air

The Soft Air program slowly brings the air pressure in the machine back to atmospheric level. This allows the plastic to wrap and stretch around sharp edges of the product which might otherwise puncture the plastic bag. Fragile products will keep in the right form when Soft air is added.

# Tabletop Sealers



- Quality engineering and build of our industrial vacuum machines
- Available in 4 sizes and 7 sealing bar configurations
- Please consult with an Trento specialist to discuss which machine will best meet your needs

Seal Bar Configuration

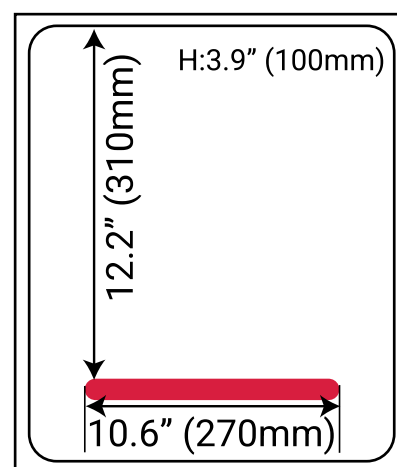

Item	11" Seal Length with 4 m <sup>3</sup> Vacuum Pump	11" Seal Length with 8 m <sup>3</sup> Vacuum Pump
Item	59006	59007
Model	TS20-L4	TS20-L8
Seal	Single	Single
Busch Vacuum Pump	4 m <sup>3</sup>	8 m <sup>3</sup>
10 Programmable Control	NO	NO
Maximum Product Height	4.33" / 110 mm	4.33" / 110 mm
Useful Chamber Size (WDH)	10.6" x 12.2" x 3.9"-5.51" (270 x 310 x 100/140mm)	10.6" x 12.2" x 3.9"-5.51" (270 x 310 x 100/140mm)
Power	0.54-0.67 hp / 400-500 W	0.54-0.67 hp / 400-500 W
Electrical	100-120V / 60Hz / 1Ph	100-120V / 60Hz / 1Ph
Weight	55 lb (25 kg)	55 lb (25 kg)
Dimensions (WDH)	14.37" x 19.68" x 13.38" (365 x 500 x 340 mm)	14.37" x 19.68" x 13.38" (365 x 500 x 340 mm)





**Seal Bar Configuration (Applies to 59008/59009/59013)**

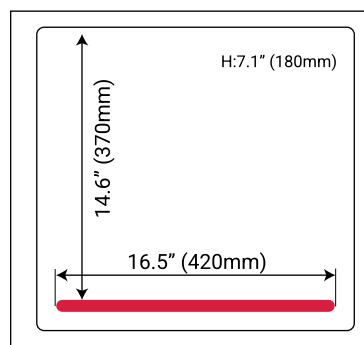

	16.5" Seal Length with 20m <sup>3</sup> Vacuum Pump	16.5" Seal Length with 25m <sup>3</sup> Vacuum Pump	16.5" Seal Length with 25m <sup>3</sup> Vacuum Pump & Gas Flush
Item	59008	59009	59013
Model	TS40-L16	TS40-L21-10P	TS40-L21-GF
Seal	Double	Double	Double
Busch Vacuum Pump	20 m <sup>3</sup>	25 m <sup>3</sup>	25 m <sup>3</sup>
10 Programmable Control	NO	YES	YES
Maximum Product Height	7" / 180 mm	7" (180 mm)	7" / 180 mm
Useful Chamber Size (WDH)	14.5" x 16.5" x 7" (368 x 420 x 178 mm)	14.5" x 16.5" x 7" (368 x 420 x 178 mm)	14.5" x 16.5" x 7" (368 x 420 x 178 mm)
Power	0.94-1.74 hp / 700-1,300 W	0.94-1.74 hp / 700-1300 W	0.94-1.74 hp / 700 - 1,300 W
Electrical	100-120V / 60Hz / 1Ph	100-120V / 60Hz / 1Ph	110 / 60Hz / 1Ph
Weight	132 lb (60 kg)	132 lb (60 kg)	132 lb (60 kg)
Dimensions (WDH)	20.66" x 21.85" x 18.11" (525 x 555 x 460 mm)	20.66" x 21.85" x 18.11" (525 x 555 x 460 mm)	20.66" x 21.85" x 18.11" (525 x 555 x 460 mm)

**Trenn Seal Available As Option for TS40/TS50/TS60**

**Seal Bar Configurations**

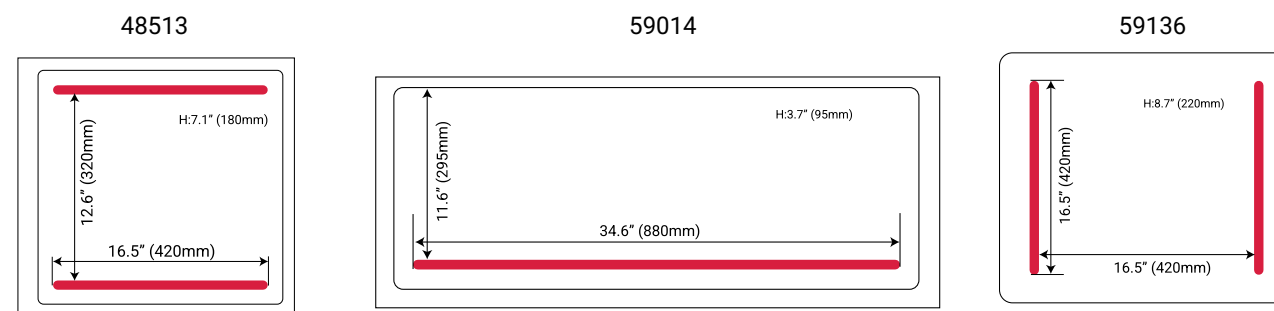

	2 x 16.5" Seal Length with 25m <sup>3</sup> Vacuum Pump	34.6" Seal Length with 25 m <sup>3</sup> Vacuum Pump	2 x 16.5" Seal Length with 25m <sup>3</sup> Vacuum Pump
Item	48513	59014	59136
Model	TS40-LL21	TS50-L21	TS60-SS16
Seal	Double	Double	Double
Busch Vacuum Pump	25 m <sup>3</sup>	25 m <sup>3</sup>	25 m <sup>3</sup>
10 Programmable Control	YES	NO	NO
Maximum Product Height	7" / 180 mm	3.9" / 100 mm	8.2" / 210 mm
Useful Chamber Size (WDH)	14.5" x 16.5" x 7" (368 x 420 x 178 mm)	34.6" x 11.6" x 3.7" (880 x 295 x 94 mm)	17.3" x 16.5" x 8.2" (420 x 440 x 208 mm)
Power	0.94-1.74 hp / 700-1300 W	1.74 hp / 1,300 W	7.38hp - 12.23hp / 5,500-9,000 W
Electrical	110 / 60Hz / 1Ph	120V / 60Hz / 1Ph	120V / 60Hz / 1Ph
Weight	132 lb (60 kg)	253.5 lb (115 kg)	187.4 lb (85 kg)
Dimensions (WDH)	21.8" x 20.6" x 18.1" (553 x 523 x 460 mm)	39" x 20.3" x 17" (990 x 515 x 432 mm)	24" x 24.6" x 19" (610x625x481mm)

**Alternative Sealing Configs Available for Special Order For TS50 (59014)**

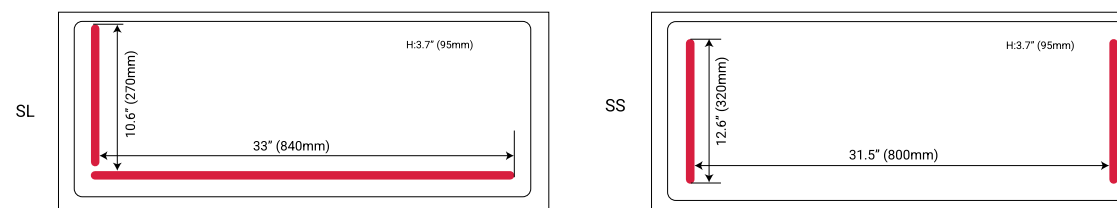

# Mobile Sealers



## Mobile and Versatile

- Portability and Flexibility:** These machines are designed for easy mobility, allowing them to be relocated between different workstations or production lines, enhancing operational flexibility and optimizing space usage in various industrial settings.
- High-Efficiency Vacuum Sealing:** Equipped with advanced vacuum technology, these machines ensure tight and secure packaging, extending the shelf life of products by removing air, preventing spoilage, and reducing the need for preservatives in food and other sensitive items.
- Versatile and Scalable:** Suitable for a wide range of industries, including food processing, pharmaceuticals, and electronics, these machines can handle various package sizes and types, making them scalable for both small-scale and high-volume production needs.



59020



50003

50005

## Seal Bar Configurations

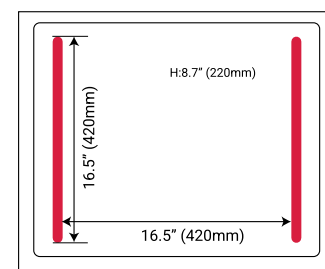

59020

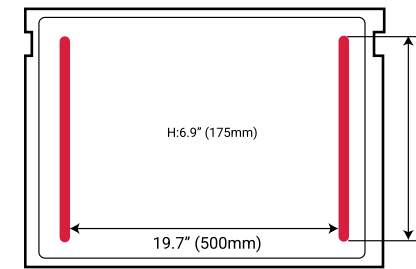

50003

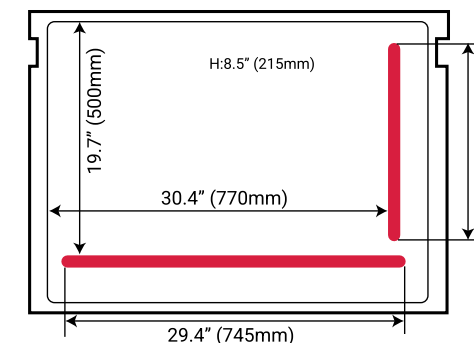

50005

Item	2 x 16" Seal Length with 25 m <sup>3</sup> Vacuum Pump	2 x 18.3" Seal Length with 40 m <sup>3</sup> Vacuum Pump	29.3"/18" Seal Length with 63 m <sup>3</sup> Vacuum Pump
Model	M10-SS	M70-SS40	M80-LS63
Seal	Double	Double	Double
Busch Vacuum Pump	25 m <sup>3</sup>	40 m <sup>3</sup>	63 m <sup>3</sup>
10 Programmable Control	NO	YES	YES
Maximum Product Height	8.7" / 220 mm	6.89" / 175mm	8.50" / 215mm
Useful Chamber Size	16.5" x 16.5" x 8.66" (420 x 420 x 220 mm)	18.3" x 19.68" x 6.89" (465 x 500 x 175 mm)	18.3" x 30.3" x 8.50" (465 x 770 x 216 mm)
Power	1.3hp (3,300 W)	4.43 hp / 3,300 W	4.69 hp / 3,500 W
Electrical	120V / 60Hz / 1Ph	220/60Hz/3Ph	220/60Hz/3Ph
Net Weight	265 lb (120 kg)	330 lb (150 kg)	440 lb (200 kg)
Net Dimensions (WDH)	26.2" x 25.2" x 40.15" (655 x 640 x 1020 mm)	27.5" x 26.7" x 40.9" (700 x 680 x 1040 mm)	35.8" x 32.6" x 41.73" (910 x 830 x 1060 mm)
Optional Item		41481 (Three pc. 25mm filler plates), 41513 (Sensor)	41508 (Four pc. 25mm filler plates), 41513 (Sensor)

## Trenn Seal Available As Option for M10/M70/M80

Alternative Sealing Configs Available for Special Order For M80

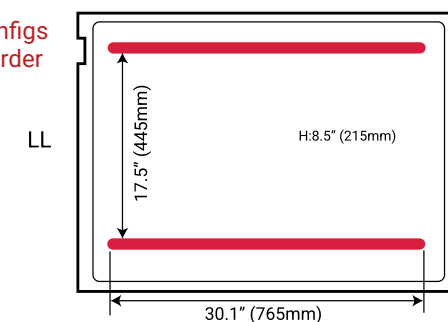

LL

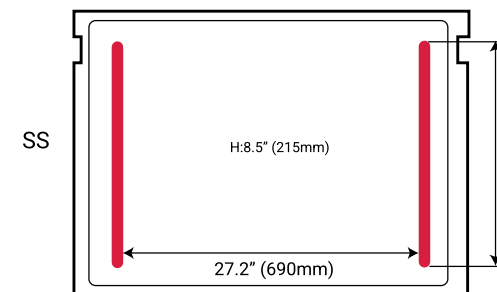

SS

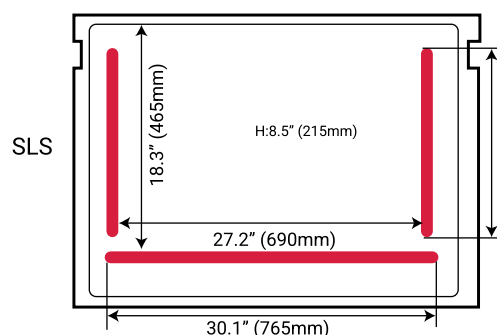

SLS

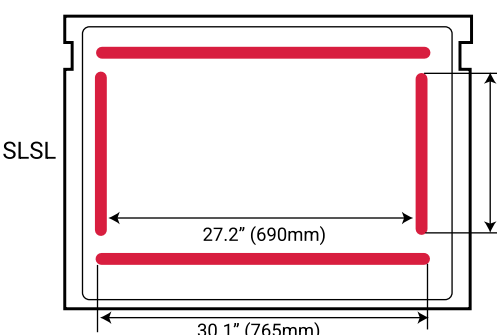

SLSL

# Double Chamber Sealers



Heavy Duty, Industrial Performance, Industrial Quality



## Seal Bar Configurations

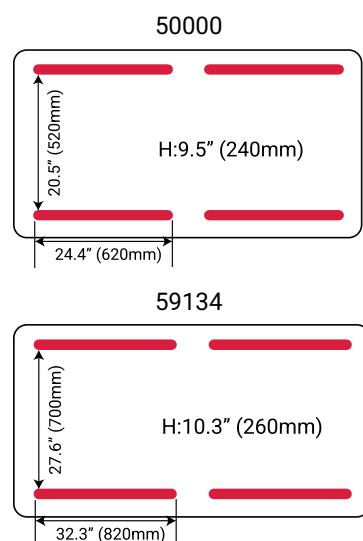

## Seal Bar Configurations

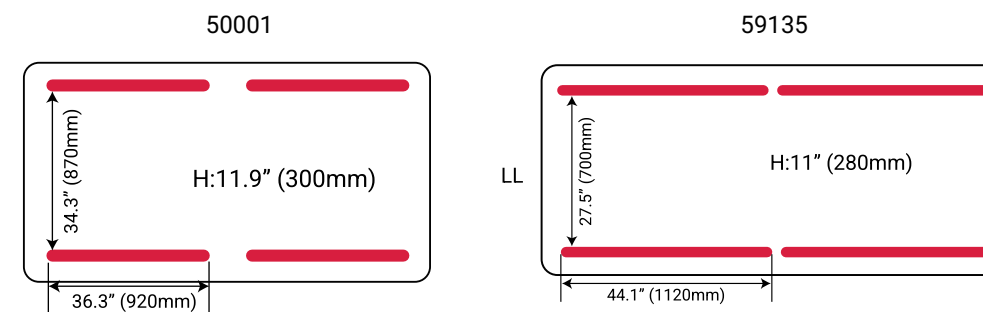

	4 x 36" Seal Length with 300 m <sup>3</sup> Vacuum Pump	4 x 44" Seal Length with 160 m <sup>3</sup> Vacuum Pump
Item	50001	59135
Model	L40-LL300	L50-LL160
Seal Type	Double	Double
Busch Vacuum Pump	300 m <sup>3</sup>	160 m <sup>3</sup>
10 Programmable Control	YES	YES
Maximum Product Height	10.63" / 270mm	10.63" / 270mm
Useful Chamber Size	34.25" x 36.22" x 11.8" (870 x 920 x 300 mm)	44.1" x 27.5" x 11" (1120 x 700 x 280 mm)
Power	8.3-13 hp / 6,200 - 9,700 W	7.37- 12 hp / 5,500 - 9,000 W
Electrical	220-380V / 60Hz / 3Ph	400V / 50Hz / 3Ph
Net Weight	1584 lb (720 kg)	1584 lb (785 kg)
Net Dimensions (WDH)	78.74" x 50" x 49" (2000 x 1270 x 1245 mm)	96.85" x 44.68" x 46.85" (2460 x 1135 x 1190 mm)
Optional Item	41512 (Eight pc. 25mm filler plates), 41513 (Sensor)	

	4 x 24" Seal Length with 100 m <sup>3</sup> Vacuum Pump	4 x 32" Seal Length with 160 m <sup>3</sup> Vacuum Pump
Item	50000	59134
Model	L10-LL100	L30-LL160
Seal Type	Double	Double
Busch Vacuum Pump	100 m <sup>3</sup>	160 m <sup>3</sup>
10 Programmable Control	YES	YES
Maximum Product Height	9" / 230mm	9.8" / 250mm
Useful Chamber Size	20.47" x 24.4" x 9.4" (520 x 620 x 240 mm)	32" x 27.5" x 9.8" (820 x 700 x 250 mm)
Power	5.90 hp / 4,400 W	5.90 hp / 4,400 W
Electrical	190-240V / 60Hz / 3Ph	400V / 50Hz / 3Ph
Net Weight	770 lb (350 kg)	770 lb (600 kg)
Net Dimensions (WDH)	56.70" x 36.22" x 47.44" (1440 x 920 x 1205 mm)	71" x 43.3" x 46" (1805 x 1100 x 1170 mm)
Optional Item	41510 (Four pc. 25mm filler plates), 41513 (Sensor)	

Alternative Sealing Configs Available for Special Order For L40/L50

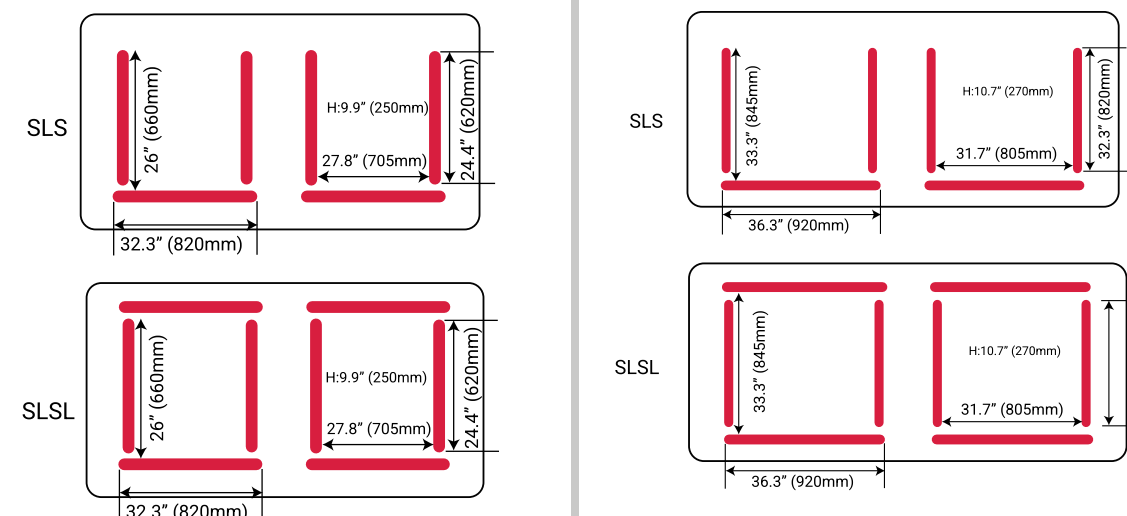

\*Shipped on Pallet

Seal Bar Configuration

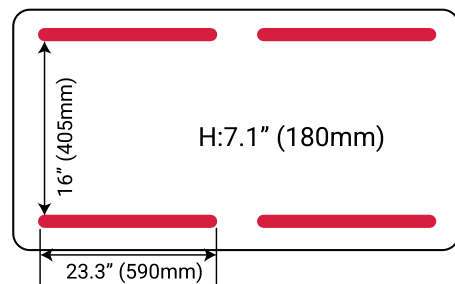

- Reliable, durable and offer flexibility in volume production
- Equipped with semi-automatic or automatic cover movement
- Double chambers can also be equipped with an external pump

4 x 23" Seal Length with Aluminum Body with 63 m <sup>3</sup> Vacuum Pump	
Item	50002
Model	L60-LL63
Seals	Double
Busch Vacuum Pump	63 m <sup>3</sup>
10 Programmable Control	YES
Maximum Product Height	7" / 180mm
Useful Chamber Size (DWH)	16" x 23" x 7" (405 x 590 x 180 mm)
Power	5.90 hp / 4,400 W
Electrical	190-240V / 60Hz / 3Ph
Net Weight	528 lb (240 kg)
Net Dimensions (DWH)	28.34" x 52.95" x 40.98" (719 x 1345 x 1040 mm)
Optional Item	41483 (Six pc. 25mm filler plates), 41513 (Sensor)

BPA Free Vacuum Sealer Bags

For chamber machines **only**. Other sizes available on special order. Vacuum bag sales are final. Seafood products should be kept under -18°C / -0.4°F.

- Locks out moisture by providing excellent protection barrier
- Stops food from spoilage and freezer burn
- Make everyday food last longer with sealed freshness
- Polyethylene / Nylon material
- These are solid core bags and can be boiled for half an hour



Item	Size	Quantity (pcs.)	Item	Size	Quantity (pcs.)	Item	Size	Quantity (pcs.)
17876	4" x 10"	1000	10232	8" x 12"	1000	10196	14" x 16"	500
10218	5" x 7"	2000	10235	9" x 12"	1000	10198	14" x 20"	500
10227	6" x 8"	1000	10181	10" x 10"	1000	10200	14" x 24"	500
10220	6" x 10"	1000	10182	10" x 12"	1000	10197	14" x 18"	500
10221	6" x 12"	1000	10183	10" x 13"	1000	21180	14" x 20"	500
10222	6" x 15"	1000	10184	10" x 15"	1000	47289	16" x 20"	500
10223	6" x 20"	1000	47074	10" x 16"	1000	47469	16" x 26"	500
10224	6" x 22"	1000	10185	10" x 16"	1000	18677	16" x 22"	500
10225	6" x 6"	1000	10186	10" x 18"	1000	10204	16" x 26"	250
10226	6" x 8.5"	1000	10187	10" x 22"	500	10203	16" x 24"	500
10219	6" x 9"	1000	10188	10" x 30"	500	10205	16" x 28"	250
10230	7" x 9"	1000	10189	12" x 12"	1000	10206	18" x 22"	250
10228	7" x 10"	1000	18676	12" x 15"	1000	10207	18" x 28"	250
10229	7" x 11"	1000	10190	12" x 14"	1000	10210	20" x 25"	250
47917	7" x 12"	1000	19125	12" x 16"	1000	10211	20" x 28"	250
10234	8" x 8"	1000	10191	12" x 16"	500	10212	22" x 34"	250
10231	8" x 10"	1000	10192	12" x 18"	500	10213	24" x 36"	250
18660	8" x 12"	1000	10193	12" x 22"	500			
10233	8" x 15"	1000	10194	12" x 24"	500			

Embossed Vacuum Bags

Required for non-chamber Sealers.

Item	Size	Quantity (pcs.)	Item	Size	Quantity (pcs.)
21468	6" x 12"	100	21471	10" x 16"	100
21469	8" x 12"	100	21472	10" x 18"	100
21470	10" x 13.7"	100			

# Food Processing

Bread Craters	169
Cheese Processing	171
Food Processors	179
Bowl Processors	181
Immersion Blender	187
Peelers	189
Dry Grinders	192
Tomato Squeezers	193
Blast Chillers	195



# 06

# Bread Graters

**OMAS**  
Food technology  
solutions

## Bread Grater with Overload Switch and Safety Cover



Item	23865
Model	BG80E/N
Safety Feature(s)	Overload Switch, Safety Cover
Power	1.5 hp / 1,120 W
Electrical	110V / 60Hz / 1Ph
Net Weight	37.4 lb (16.82 kg)
Net Dimensions (WDH)	9.84" x 9.84" x 22.44"
Gross Weight	44 lb (20 kg)
Gross Dimensions	13" x 22" x 24.5"

In a professional kitchen, every tool should serve to enhance efficiency, reduce waste, and improve product consistency. A **bread grater** is a simple yet highly effective tool that accomplishes all three. Rather than discarding day-old or unsold bread, restaurants can repurpose it into fresh, fine bread crumbs—ideal for breading, stuffing, or adding texture to dishes. This not only reduces food waste but also turns what would be a loss into a profitable ingredient.

Bread graters also ensure a consistent crumb texture, something that can be difficult to achieve manually. Whether you need coarse crumbs for a crispy mac and cheese topping or fine crumbs for delicate meatballs, a bread grater delivers uniform results every time. This consistency improves the overall quality of dishes and helps maintain culinary standards across shifts and staff members.

Additionally, investing in a bread grater saves valuable time and labor. What might take a line cook several minutes to do by hand can be done in seconds with a machine—freeing up staff for other prep tasks and improving kitchen workflow. Over time, the savings in labor and reduced waste can significantly offset the cost of the equipment.



# Cheese Processing

## Light and Moderate Duty Stainless Steel Cheese Graters



- Allows for easy grating of hard cheese and stale breads
- Designed to be suitable for small to medium applications
- Ironed steel drum, stainless steel basins and hoppers
- 39884 has a brake motor



Item	48109
Model	GR-IT-0373R-M
Product Capacity	44 lb (20 kg) per hour
Micro-switch	Yes
Power	370 W / 0.5 hp
Electrical	110V / 60Hz / 1Ph
Net Weight	18 lb (8 kg)
Net Dimensions (WDH)	10.25" x 6.5" x 12"



21719

Item	21719
Model	GR-IT-0373-M
Production Capacity	44 lb (20 kg) per hour
RPM	1670
Power	0.5 hp / 370 W
Electrical	110V / 60Hz / 1Ph
Micro-switch	Yes
Net Weight	16 lb (7.27 kg)
Net Dimensions (WDH)	10.35" x 11.4" x 11.75"



11404

Item	In Compliance with Quebec Safety Standards	
	21719	11404
Model	GR-IT-0373-M	GR-IT-0746-M
Production Capacity	44 lb (20 kg) per hour	88 lb (40 kg) per hour
RPM	1670	1670
Power	0.5 hp / 370 W	1 hp / 750 W
Electrical	110V / 60Hz / 1Ph	110V / 60Hz / 1Ph
Micro-switch	Yes	Yes
Net Weight	16 lb (7.27 kg)	36 lb (16.36 kg)
Net Dimensions (WDH)	10.35" x 11.4" x 11.75"	10.75" x 15.4" x 14.8"

# Santos Cheese Shredder / Grater #02



- Comes with 1 standard disc assembly with 3mm holes
- Stainless steel and sanitary cast aluminum Antimicrobial painted body
- Facilitates cleaning and maintenance (removable housing and disc)
- Suitable for cheese (hard), grating, and shredding (soft) with optional discs.



40950



40952



40953



40954



40956 - specific disc for fondue, mozzarella, chocolate



40955 - specific disc parmesan, dried fruits, peanuts (very fine)



40951 - standard disc

Item	40619
Model	SANTOS 02
Production	110 lb (50 kg) per hour
RPM	1800
Power	650W / 0.87 hp
Amps	5.4 A
Electrical	100-120V / 60Hz / 1Ph
Net Weight	32 lb (14.55 kg)
Net Dimensions (WDH)	16.5" x 10" x 14"
Gross Weight	35 lb (15.88 kg)
Gross Dimensions	12" x 18" x 14"

**OPTIONAL DISCS AVAILABLE UPON REQUEST**

- ø2mm holes (40950)
- ø4mm holes (40952)
- ø6mm holes (40953)
- ø8mm holes (40954)
- Specific disc for fondue, mozzarella, chocolate (40956)
- Specific disc for parmesan, dried fruits, peanuts - very fine (40955)

# Light and Moderate Duty Stainless Steel Cheese Graters



11405/39884



11403

Item	In Compliance with Quebec Safety Standards	
	11403	11405
Model	GR-IT-1119	GR-IT-1119-M
Product Capacity	132 lb (60 kg) per hour	132 lb (60 kg) per hour
RPM	1030	1030
Power	1.5 hp / 1,120 W	1.5 hp / 1,120 W
Electrical	110V / 60Hz / 1Ph	110V / 60Hz / 1Ph
Net Weight	42 lb (19 kg)	44 lb (20 kg)
Net Dimensions (WDH)	10.75" x 15.4" x 14.8"	10.75" x 15.4" x 14.8"
Micro-switch	No	Yes
Brake Motor	No	No

# Heavy Duty Stainless Steel Cheese Graters

## 2HP Heavy-duty Cheese Grater

- Comes with a transparent Plexiglas container for a better view of the processed cheese
- Aluminum head and stainless steel drum are easily removed without tools that allows for easy cleaning
- Self cooled motor for high performance and continuous use



Item Number	19921
Model	GR-IT-1491-B
Description	Cheese Grater with Brake Motor
Production Capacity	240 lb (109 kg) per hour
RPM	1400
Power	2 hp / 1,490 W
Electrical	240V / 60Hz / 1Ph
Mouth Dimensions	3.75" x 7.5
Net Weight	74 lb (33.64 kg)
Net Dimensions (WDH)	23" x 10.5" x 19"



19921

## 4HP Heavy-duty Cheese Grater

- Large bright finished aluminum grating mouth
- Stainless steel drum
- Brake motor
- High efficiency ventilated motors for continuous operation
- Large plexiglass receiving tray
- Safety micro-switches on lever and receiving tray



Item	39498
Model	GR-IT-2983-B
Production Capacity	480 lb (218 kg) per hour
RPM	1400
Power	4 hp / 2980 W
Electrical	208V / 60Hz / 3Ph
Mouth Dimensions	6.25" x 11.75"
Net Weight	143 lb (65 kg)
Net Dimensions (WDH)	29.52" x 25.20" x 25.20"
Gross Weight	163 lb (74 kg)
Gross Dimensions	34" x 33" x 29"



39498

# Super Heavy Duty Pneumatic Stainless Steel Cheese Graters



- Built entirely in AISI 304 stainless steel
- New fast-extraction system with cogwheel for daily cleaning
- 45403 and 47931 are oversized industrial cheese graters
- Cylinder with pneumatic thrust

45404



Item	45404	47930
Model	GR-IT-0300-H	GR-IT-0300-CR800
Production Rate/Hr	up to 1500kg / hr dependent on cheese type	
Power	5.5 hp / 4,000 W Self-Braking Motor	20 hp / 15,000 W Motor
Electrical	208V / 60Hz / 3Ph	
Weight	661 lb (380 kg)	(Unit + Screen) 661 lb + 198 lb (380 kg) + 90 kg
Dimensions	76.7" x 31.5" x 47"	
Optional Vibrating Screen Included	NO	YES - 33.6" x 41" x 32"

Item	45403	47931
Model	GR-IT-1500-H	GR-IT-1500-CR1200
Production Capacity	2646 lb (1200 kg) per hour 3307 lb (1500 kg) per hour	
Power	20 hp / 1490 W Self-Braking Motor	
Electrical	208V / 60Hz / 3Ph	
Weight	1874 lb (850 kg)	(Unit + Screen) 1847 lb + 308 lb / 850 kg) + 140 kg)
Dimensions	98.6" x 44" x 53"	
Optional Vibrating Screen Included	NO	YES - 47" x 55.6" x 35"

# Industrial Wire Cutting Machine for Cheese



Designed for efficiency and precision, it delivers consistent, high-quality cuts at high volumes, improving productivity and reducing waste. Ideal for businesses specializing in high volume cheese operations that receive whole cheese wheels for processing.

- Built entirely in AISI 304 stainless steel
- Twin push-button machine start-up
- Motor with variable cutting-speed
- Work surface in AISI 304 stainless steel
- Food-grade Plexiglas safety housing

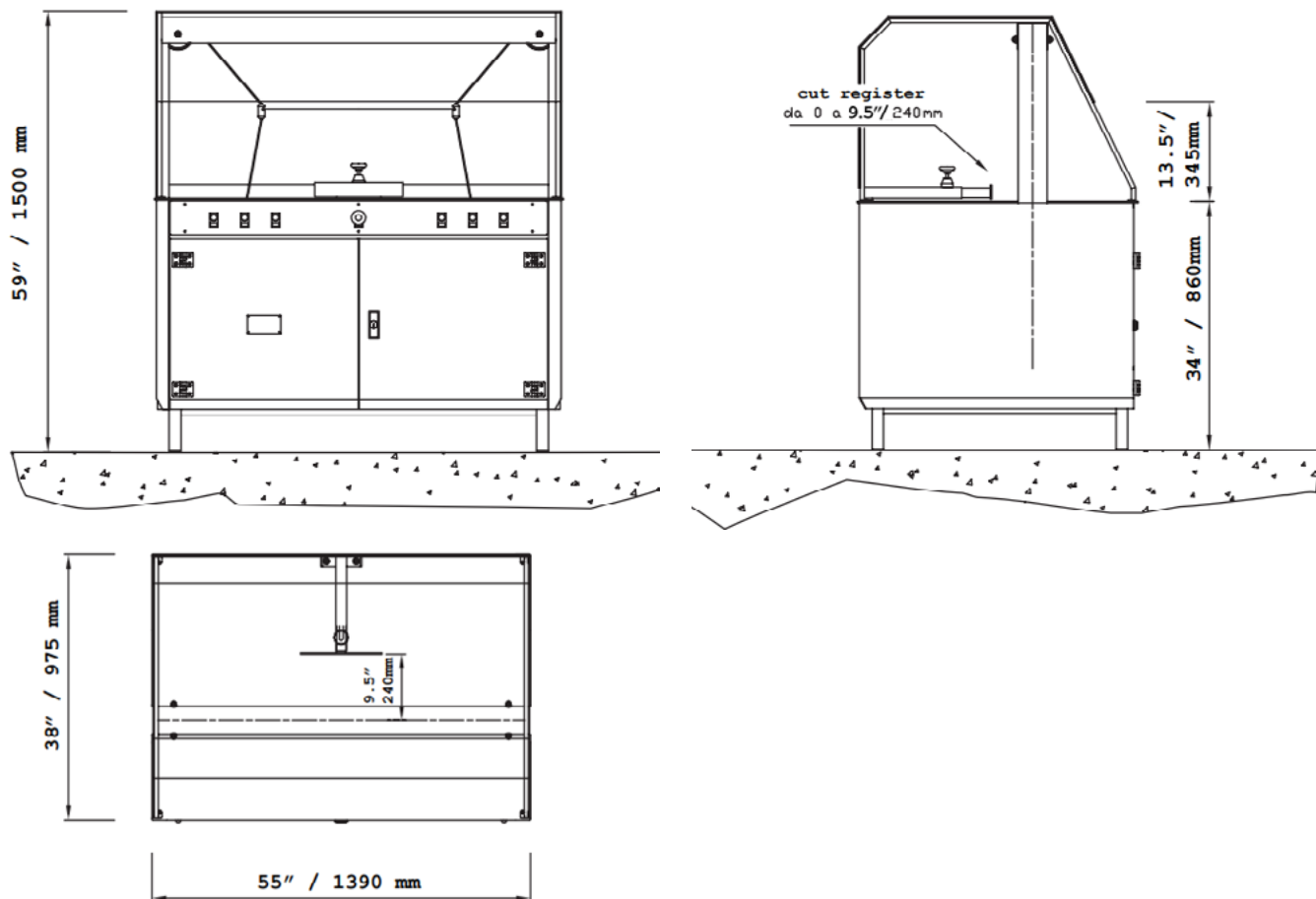

Item	45412
Model	GR-IT-1000-C
Cut Shape	Cube, Slice
Accepted Types	Semi-Hard, Hard
Wire Material	Steel
Power	1,300 W
Electrical	120-220 V / 60 Hz / 1 Ph
Cutting Speed	Variable (Engine Frequency: 20Hz-85Hz)
Net Weight	440 lb (200 kg)
Net Dimensions (WDH)	54.7" x 41" x 59" (1390 x 1050 x 1500 mm.)
Gross Weight	880 lb (400 kg)
Gross Dimensions (WDH)	58.7" x 45.3" x 63" (1491 x 1150 x 1600 mm)



# Food Processors

All discs are sold separately



Item	10927
Model	FP-IT-0300
Mouth Opening	3 1/16" x 6 1/4"
Disc Speed	300 RPM
Power	0.7 hp / 520 W
Electrical	110V / 60Hz / 1Ph
Bin Size	5.75" x 11.75" x 7.5"
Net Weight	54 lb (24.55 kg)
Net Dimensions	20" x 11" x 19"



- Easy to use for all types of vegetables, cheese, and many other product
- Hinged lid allows for easy cleaning and changing of disks
- Wide selections of discs are available
- Made of aluminum alloy and stainless steel construction
- Gentle on soft products with inclined design that drops product below without pushing. Ideal for products vulnerable to pressing forces such as soft cheese

## Food Processor Discs

### Shredding

Item	Description
10089	Shredding discs: 2 mm
10090	Shredding discs: 3 mm
22323	Shredding discs: 4 mm
10093	Shredding discs: 7 mm
22324	Shredding discs: 7 mm
10094	Shredding discs: 9mm (mozzarella)



### Grating

Item	Description
10095	Grating Disc 1mm

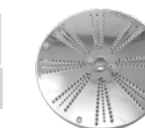

### Slicing

Item	Description
24204	Slicing Disc, curved 1 mm
22325	Slicing Disc, straight 2 mm
10074	Slicing Disc, straight 3 mm
10075	Slicing Disc, straight 4 mm
22326	Slicing Disc, straight 4 mm
10076	Slicing Disc, curved wave 5 mm
22327	Slicing Disc, straight 8 mm
16448	Slicing Disc, straight 8 mm
22328	Slicing Disc, straight 10 mm
22333	Slicing Disc, straight 14 mm



### Cubing / Baton

(For optimal results, use with slicing disc at similar thickness)

Item	Description
10123	Cubing Disc 8 mm
10120	Cubing Disc 10 mm
10121	Cubing Disc 14 mm
10122	Cubing Disc 20 mm
10118	Baton Disc 6 mm
10119	Baton Disc 8 mm
10117	Baton Disc 10 mm



### Julienne Strip

Item	Description
10082	Julienne Strips Disc 4 mm
10084	Julienne Strips Disc 6 mm
10086	Julienne Strips Disc 8 mm
10081	Julienne Strips Disc 10 mm



# Bowl Processors



10830



47083



47261



47269

## 3 Qt Bowl Cutter 0.4 HP 110V

10830



## 4 Qt Bowl Cutter 0.5 HP 110V

47261



## 6 Qt Bowl Cutter 0.5 HP 110V

47269



## 9 Qt Bowl Cutter 1 HP 110V

47083



Item	10830	47261	47269	47083
Model	FP-IT-0003	FP-IT-0004-VT	FP-IT-0006-VT	FP-IT-0009-VT
Capacity	3 qt (2.8L)	4 qt (4L)	6 qt (6L)	9 qt (9L)
RPM	2800	600-2800		
Power	0.4 HP (300W)	0.5 HP (350W)		1 HP (700W)
Electrical	110V / 60Hz / 1Ph		110V / 60Hz / 1Ph	
Net Weight	28 lb (12.7 kg)	29.8 lb (13.5 kg)	32 lb (14.5 kg)	50.7 lb ( 50 kg)
Gross Weight	29 lb (13.1 kg)	35.3 lb (16 kg)	37.5 lb (17 kg)	57.3 lb (26 kg)
Net Dimensions	21" x 10" x 11.5" (533 x 254 x 292 mm)	18" x 11.7" x 11.8" (457 x 296 x 300 mm)	18" x 12" x 14.3" (457 x 304 x 362 mm)	22" x 13.7" x 16.5" (560 x 348 x 420 mm)
Gross Dimensions	19" x 15" x 15" (482 x 381 x 381 mm)	19.9" x 11.8" x 14.6" (505 x 300 x 370 mm)	11.8" x 19.9" x 17" (300 x 505 x 430 mm)	14.4" x 23.6" x 19" (365 x 600 x 485 mm)

The all new

# pacojet

Experience meets innovation. Redefine classic preparation methods and elevate market-fresh ingredients into culinary masterpieces.



## Unleash Culinary Excellence

From the top chefs' secret helper to an absolute 'must-have', the Pacojet has become indispensable in successful professional kitchens worldwide. Why? This unique cooking system combines unlimited creativity with superb results while saving costs.

- **A burst of flavor on the tongue:**  
Pacotizing® increases the surface area of the ingredients many times over, intensifying the aromas.
- **An explosion of color:**  
The special processing technique preserves the fresh natural colors of your ingredients.
- **Velvety-smooth mouthfeel:**  
Pacotizing® produces ultra-fine, airy textures.

### Large Touchscreen:

The large touchscreen provides intuitive user guidance with an animated assistance feature. The user interface is designed for use in professional kitchen environments.

### Save Recipe Settings:

Saving and loading settings for preparing your favorite recipes makes your kitchen even more efficient.

### Device Settings:

- **The Jet® mode:** Choose between pacotizing® with the classic Pacotize® mode in 4 minutes or the Jet® mode in 90 seconds. The Jet® mode allows you to very quickly prepare certain recipes with a high sugar and fat content (e.g., ice creams). This means you can further increase your productivity. Expanded automatic repeat mode
- **Pacotize® on repeat up to 10 times:** This results in particularly light and creamy consistencies with maximum time efficiency.
- **Work with overpressure or normal pressure:** When using overpressure, the Pacojet works at up to 1 bar. This results in a volume expansion of approx. 20–30%. This is ideal for creating foods such as mousses with a creamy-light consistency and for intensifying flavors.



- **Tool Detection** - ensures that the correct tool has been properly attached.
- **Spray Guard Detection** - you can be confident that the spray guard is positioned correctly.
- **Max Capacity Notification** - tells you when the pacotizing® beaker is too full.
- **WiFi Connection:** Connecting the Pacojet via WiFi allows the Pacojet Service Center to detect error sources quickly and easily.
- **Standby:** During prolonged periods of inactivity, the Pacojet switches to energy-saving standby mode
- **Easy Cleaning:** Thanks to the display-guided cleaning program, the device can clean easily at the press of a button and without additional equipment.
- **Exceptionally Quiet** - Reduces kitchen noise

### PACOJET 4 Included accessories (1 of each)

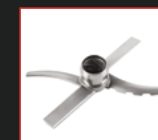

Pacotizing® blade

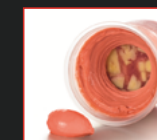

Synthetic Beaker



Protective Outer Beaker



Beaker Lid (White)



Spray Guard



Start guide and safety instructions



Item	47755
Model	PACOJET 4
Beaker Capacity	1L
Maximum Beaker Fill Volume	0.8 L = 10 portions
Power	1,500 W
Electrical	120V / 60Hz / 1Ph
Overpressure	approx. 1 bar
Sound emission	76.4 db (A)
Pacotizing Temperature	-18 to -23 °C / 0 to -9 °F
Net Weight	50 lb (22.5 kg)
Net Dimensions (WDH)	8" x 14" x 19.6"
Gross Weight	51 lb (23 kg)
Gross Dimensions	10" x 16" x 21"



46702



46701



39675



47855



47741



47854



39674



47851



41698

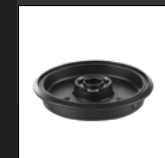

47853



47852



47792

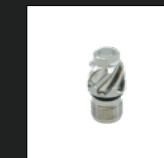

47793



41699

Item	Item Name	Description	Compatible	Quantity / Case (pcs.)
46702	Pacojet Transparent Synthetic Pacotizing Beaker with Lid - set of 12	For additional pacotizing® beaker requirements	Pacojet 4 Pacojet 2 Plus & legacy models (with Protective Beaker 47854)	Set of 12
46701	Pacojet Transparent Synthetic Pacotizing Beaker set of 10 + 1 Chrome Steel Protective Outer Beaker	For additional pacotizing® beaker requirements	Pacojet 2 Plus & legacy models	Set of 10 + 1
39675	Chrome Steel Pacotizing Beakers with Lids	For additional chrome steel pacotizing® beaker requirements	Pacojet 4 (with 47851), Pacojet 2 Plus & legacy models	Set of 4
47855	White Beaker Lid	Stackable Lid for Pacotizing Beaker	All Pacotizing Beakers	1
47741	Pacojet Synthetic Protective Outer Beaker for Synthetic Beakers #46702	The Pacojet Synthetic Protective Outer Beaker is specifically designed for use with synthetic beakers. This protective outer beaker provides an additional layer of durability and safety, safeguarding the inner beaker during the Pacojet process	Pacojet 2 Plus & legacy models	1
47854	Protective Beaker For Synthetic Pacotizing Beakers		Pacojet 4	1
39674	Protective outer beaker For Synthetic Pacotizing Beakers	Pacojet Synthetic Protective Outer Beaker for Chrome-Steel Pacotizing® Beaker	Pacojet 2 Plus, Pacojet 2, Pacojet Junior and Pacojet 1	1
47851	Synthetic Protective Outer Beaker	Protective outer beaker PJ4 for chrome steel beakers	Pacojet 4	1
41698	Insulating Box for Chrome Steel Pacotizing Beakers with Lids	The practical Insulating Box for 4 pacotizing beakers is a big help to protect your deep-frozen preparations from undesired warmth. Proven very handy to transport deep-frozen pacotizing beakers	Only for Chrome Steel Pacotizing Beakers with Lids (39675)	1 (Fits 4 Beakers)

Item	Item Name	Description	Compatible	Quantity/Case (pcs.)
47853	Spray Guard	The splash guard with pre-scraper protects the interior of the Pacojet from dirt	Pacojet 4	1
47852	Preliminary Scraper		Pacojet 4	1
47792	Pacotizing Blade	Pacotizing® blade for Pacojet 4 /Pacojet 2 Plus	Pacojet 4 / Pacojet 2 Plus	1
47793	Tool Coupling	Replacement for existing coupling tool for Pacojet 4 and 2 PLUS; Also useful for using new blades with legacy models	Pacojet 4 / Adapts legacy models (Pacojet 1 & 2)	1
41699	Display Protective Foil	Clean the display with a clean, soft, lint-free cloth to remove oil, grime and dust. Particle remnants can cause blisters underneath the protective foil.	Pacojet 2 / Pacojet 2 Plus	1

**Cleaning Tab for Pacojet**

The high-quality Pacojet cleaning tabs are specifically developed for the professional and efficient cleaning of Pacojet devices and are very easy to use.

**What Are The Advantages of The Pacojet Cleaning Tabs?**

- Dosage and efficiency are perfectly matched to the needs of the Pacojet
- Antibacterial cleaning (non-foaming), which eliminates 99,99 % of bacterial contamination
- Compact and easy to handle
- Support cleaning according to HACCP standards



48700

**Why Is A Regular Cleaning of The Pacojet Important?**

- Preventing germ infestation of the device and ensuring necessary hygiene standards (HACCP)
- Extending the service life of the Pacojet
- Ensuring high product quality and unadulterated taste experience

Item	48700
Description	Cleaning Tab for Pacojet – 60 pcs per jar
Compatible With	Pacojet 4, Pacojet 2 Plus and all the older models

**The Coupe Set / Coupe Set PLUS\***

extend the Pacojet's range of functions to working with fresh, non-frozen foods.

Item	47772	46531
Compatibility	Pacojet 4	Pacojet 2 Plus
Includes	<p><b>3 Items</b></p> <ul style="list-style-type: none"> <li>• <b>2-Blade Cutter:</b> for all purposes</li> <li>• <b>Whipping Disc:</b> Creams, egg whites or mix/foam, milkshakes etc.</li> <li>• <b>Cutter Tong:</b> Lets you safely affix the cutter blades</li> </ul>	<p><b>4 Items</b></p> <ul style="list-style-type: none"> <li>• <b>2-Blade Cutter:</b> For course textures: meat, fish, herbs, vegetables</li> <li>• <b>4-Blade Cutter:</b> For fine textures: mousses, purees</li> <li>• <b>Whipping Disc:</b> Creams, egg whites or mix/foam, milkshakes etc.</li> <li>• <b>Cutter Tong:</b> Lets you safely affix the cutter blades</li> </ul>



47772



46531

# Commercial Variable Speed Immersion Blender



The power head is easy to detach and clean, making it a convenient option for busy kitchens. Whether you're blending soups, pureeing vegetables, or creating smoothies, this immersion blender is up to the task.

- Self-regulating variable speed control
- Stainless steel construction provides durability
- Rubber cover on the lower part of the body
- Innovative lightweight design and ergonomic handle
- Double-insulated motor
- Fiberglass-Nylon lighter and sturdier than plastic
- Self monitoring speed control that adjusts as product becomes thicker or softer



Item	47712
Model	BL-IT-0075-VT
RPM	2300 – 15000
Power	750 W / 1 hp
Electrical	120V / 60Hz / 1Ph
Net Weight	12.7 lb (5.7 kg)
Net Dimensions (WDH)	7.5" x 7.5" x 20"
Optional Accessories	47713 - 18" Shaft 47822 - 14" Shaft 47823 - 15" Whip



# Potato Peelers

## Super Heavy Duty Potato Peeler



Refuse Bin (AH531) Sold Separately

### Heavy Duty Potato Peeler & Refuse Bin



Refuse Bin (64678) Sold Separately

Structured in AISI 304 stainless steel and IP55 plastic box control board protection

- Safety micro switch assembled on the cover and chute
- Floor water discharge, and unbreakable transparent plastic cover



44184 & 64678 (Sold Separately)

	22lb Capacity	39.6lb Capacity
Item	44184	44185
Model	PP-IT-0010	PP-IT-0018
Capacity	22 lb (10 kg)	39.6 lb (18 kg)
Output (Approx.)	661.4 lb /hr.	1102.3 lb /hr.
Potato Peeling Cycle	90-120 sec.	120-150 sec.
Flexible Pipe Feeding	3/4" / 19.05 mm	3/4" / 19.05 mm
Water Temperature	5°C - 20°C (41°F - 68°F)	5°C - 20°C (41°F - 68°F)
Side Discharge Manifold	2" (Dia.)	2" (Dia.)
Lower Discharge Manifold	1.6" (Dia.)	1.6" (Dia.)
RPM	320 RPM	320 RPM
Power	0.75 hp / 550 W	1.2 hp / 900 W
Electrical	115V / 60Hz / 1Ph	115V / 60Hz / 1Ph
Net Weight	88 lb (40 kg)	99.2 lb (45 kg)
Net Dimensions (WDH)	20.8" x 26" x 33.5"	20.8" x 26" x 37.4"
Optional Item	64678 - Refuse Bin	

- Ideally suited for restaurants, busy kitchens, and hotels
- Designed to handle 66 lb of potatoes, and made from AISI 304 stainless steel.
- Features include: safety micro switch, floor water discharge, and a stainless steel cover
- Has a digital and user-friendly control panel



Item	47055
Model	PP-IT-0030
Capacity	66.1 lb (30 kg)
Working Capacity	700 potatoes/hour
Discharge Manifold	Lower: $\varnothing$ 1.6" / $\varnothing$ 40 mm Side: $\varnothing$ 2" / $\varnothing$ 50 mm
Peeling Cycle	120 - 150 seconds
Water Temperature	5 - 20°C / 41 - 68°F
Flexible Pipe Feeding	3/4" / 19 mm
RPM	240 RPM
Power	1.2 hp / 9,000 W
Electrical	220V / 60Hz / 1Ph
Net Weight	132.3 lb (60 kg)
Net Dimensions (WDH)	21.7" x 31.5" x 35.4"
Optional Item	AH531 - Refuse Bin

# Dry Grinders

## Santos Dry Spice Grinder Santos Poppy Seed Grinder



- Sturdy and powerful grinder with drawer
- Constructed with a stainless steel and aluminum body
- Dishwasher safe and easy-to-clean
- Reliable commercial motor with 1800 RPM
- High resistance and the long-lasting horizontal axis grinding discs
- Its plastic drawer is made without bisphenol
- Compatible with coffee and dry spices
- Adjusting button to select the grinding size: from very fine to coarse.
- 01PV model specialized for poppy seed grinding

	Dry Spice	Poppy Seed
Type	46080	44116
Item	SANTOS 01P	SANTOS 01PV
Model	30 lb (14 kg)/ hour	
Production	1,8 lb (800 g)	
Drawer Capacity	Ø 63.5mm (2,5")	
Grinding discs	Stainless steel and aluminum body	
Material	1800	
RPM	650 W	
Power	5.9 A	
Amps	120V / 60Hz / 1ph	
Electrical	33 lb (15 kg)	
Net Weight	13" x 10" x 22"	
Net Dimensions (WDH)		

# Tomato Squeezers



## Meat Grinder Attachments for Tomato Squeezer

Item	Description
44019	#5 Meat Grinder Attachment for 18901
20170	# 12 Meat Grinder Attachment for 18902 and 18903 Tomato Squeezer
20169	# 22 Meat Grinder Attachment for 18903 Tomato Squeezer



- Suitable for tomato sauce, jams and fruit juice
- Propeller in acetal resin which is suitable for food contact and anti-friction
- Filter cone, drip pan, anti-spray guard and big capacity funnel are entirely built in stainless steel AISI 304
- Towing pin in steel and nylon 6.6
- Body in cast iron treated for food use with epoxy powder baked at 300°C
- The oil used is "Long Life" and suitable for occasional food contact; it doesn't need any replenishing or replacement
- Axial reduction unit with oil-bath metal gears (nylon 6.6 gears are used for 18901)
- Protection class IPX5
- Cooling fan, and tight switch-condenser box are made in plastic material (fan covers in stainless steel)
- Continuous duty, electric induction motors



18901



18902



18903

Item	18901	18902	18903
Model	TS-IT-0110-S	TS-IT-0110-M	TS-IT-0110-L
Power	0.3 hp (223 W)	0.4 hp (300 W)	0.8 hp (595 W)
Electrical	115V / 60Hz / 1Ph	115V / 60Hz / 1Ph	115V / 60Hz / 1Ph
Worm RPM	110	110	110
Net Weight	20 lb (9 kg)	31 lb (14 kg)	40 lb (18.18 kg)
Net Dimensions (WDH)	20.5" x 9.5" x 14"	27" x 12" x 13"	28" x 11.5" x 17"



20169/20170



44019

# Blast Chillers

Blast Chillers cool food rapidly by circulating cold air through the unit until Temperature Range falls down to safe levels. These units are designed to quickly lower the Temperature Range of foods to minimize bacterial growth ensuring food down through the danger zone within minutes compared to the hours it takes when stored in a refrigerator.

Blast chillers also offer an advantage over traditional freezer by rapid freezing the food which produces fewer and smaller ice crystal resulting with minimal damage to the food. This improves the frozen food's texture once it is reheated. Although they are typically more expensive than traditional refrigerators, they are mostly used in hotels, restaurants, and food operation business.



46673



48704



48702



48703



- External scotch-brite finish with internal glossy finish
- 60-mm high density polyurethane foam insulation
- CFC and HCFC free
- Designed with a digital control panel and core probe
- Core probe included
- Door switch for stopping the fan
- Removable grids-racks for easy cleaning
- Manual defrosting
- Automatic cold storage at the end of the cycle

	3 (13" x 21") Trays	5 (18" x 26") Trays	6 (18" x 26") Trays	10 (18" x 26") Trays
Item	48702	48703	46673	48704
Model	BC-IT-0031	BC-IT-0051	BC-IT-0906-T	BC-IT-0101
Cooling Capacity at 3°C (37.4°F)	26.5 lb (12 kg)	40 lb (18 kg)	48.5 lb (22 kg)	71 lb (32 kg)
Cooling Capacity at -40°C (-40°F)	17.6 lb (8 kg)	88 lb (12 kg)	33 lb (15 kg)	55 lb (25 kg)
Cooling Loading	628 W / 0.84 hp	995 W / 1.3 hp	1,194 W / 1.6 hp	1,559 W / 2.1 hp
Refrigerant	R404A / R290			
Power	648 W / 0.88 hp	828 W / 1.1 hp	922 W / 1.2 hp	1,355 W / 1.8 hp
Amps	4.2 A	4.8 A	5.5 A	6.5 A
Electrical	220V / 60Hz / 1Ph			
Number Of Trays	3 (Size 13" x 21")	5 (Size 18" x 26")	6 (Size 18" x 26")	10 (Size 18" x 26")
Interior Dimensions (DWH)	13.9" x 21.7" x 11"	27.6" x 18.5" x 15"	27.6" x 18.5" x 19"	27.6" x 18.5" x 30"
Net Dimensions (WDH)	24" x 25.6" x 26"	32" x 32" x 36.6"	32" x 32" x 44"	32" x 32" x 66"
Net Weight	150 lbs.(68kg)	236 lb(107 kg)	303 lb(137 kg)	312 lb(142 kg)

# Meat Processing

Band Saws	197
Bowl Cutters	199
Meat Tenderizers	205
Meat Grinders	207
Meat Mixers	211
Meat Slicers	215
Sausage Stuffers	245

# 07



# Tabletop Band Saw



45507

## Reliable and Sturdy

Ideal for butcher shops, hotels, restaurant kitchens, and supermarkets.

Perfect for cutting both fresh and frozen meat/ fish and bones. The durable structure is constructed with high quality powder-painted aluminum. Easy to clean and safe to use

## 60" Blade / 1.2 HP Motor Medium Duty

45559



## 72" Blade / 1.2 HP Motor Medium Duty

45506



## 72" Blade / 1.2 HP Motor Medium Heavy Duty

45507



45506



45559

Item	45506	45507	45559
Model	BS-IT-1829-M	BS-IT-1829-L	BS-IT-1524
Blade Length	72" (1830 mm)	72" (1830 mm)	60" (1520 mm)
Cutting Capacity	10.6" x 8.3" (270 x 210 mm)	10.6" x 8.3" (270 x 210 mm)	7.5" x 7.3" (190 x 185mm)
Motor	1.2 HP (0.9 kW)	1.2 HP (0.9 kw)	1.2 HP (0.9 kw)
Electrical	120V / 60 Hz / 1 Ph		
Amps	12.5 A		
Net Weight	71.7 lbs. (32.5 kg)	79.4 lbs. (36kg)	68.3 lbs. (31kg)
Gross Weight	81.6 lbs. (37 kg)	88.2 lbs. (40kg)	75.0 lbs.(34 kg)
Net Dimensions	20.9" x 18.1" x 35" (530 x 460 x 890 mm.)	21.3" x 18.5" x 35" (540 x 470 x 890 mm.)	18.1" x 16.9" x 28.7" (460 x 430 x 730 mm.)
Gross Dimensions	36.2" x 18.1" x 16.5" (920 x 460 x 420 mm.)	36.2" x 18.1" x16.5" (920 x 460 x 420 mm.)	31.5" x 17.7" x 15.7" (800 x 450 x 400 mm.)

# Bowl Cutters

## Medium Duty

### Innovative and efficient

Trento's commercial bowl cutters are versatile and powerful kitchen appliances that can chop, slice, shred, and mix various ingredients in a large stainless steel bowl. They are designed for high-volume food preparation in restaurants, catering businesses, and other food service establishments. These machines can save time and labor by performing multiple tasks with one machine. They are ideal for commercial kitchens that need to prepare large quantities of sauces, dressings, dips, spreads, and other products.

Variotronic self monitoring system ensures smooth cutting as the speed is adjusted in real-time to keep the same power as product becomes softer or thicker.



47776



47711

### 8 Qt Commercial Electric Food Processor/ Bowl Cutter 1 HP

47711



### 16 Qt Commercial Electric Food Processor/ Bowl Cutter 2 HP

47776



Item	47711	47776
Model	FP-IT-0006	FP-IT-0012
Capacity	8 qt (7.5L)	16 qt (15L)
RPM	1680	1680
Power	1 HP (750W)	2 HP (1400W)
Electrical	120V / 60Hz / 1Ph	
Net Weight	134 lb (60.8 kg)	156 lb (70.8 kg)
Gross Weight	220 lb (99.8 kg)	240 lb (108.9 kg)
Net Dimensions	20.3" x 32.8" x 18.6" (516 x 832 x 473 mm)	23.1" x 35.5" x 20" (588 x 902 x 508 mm)
Gross Dimensions	32" x 48" x 34" (812 x 1219 x 863 mm)	32" x 48" x 34" (812 x 1219 x 863 mm)

# Heavy Duty

- 7" touchscreen indicating knife speed, temperature, elapsed time etc,
- Variable cutting speed: variable 500 - 3500 RPM + 4 programmed speeds
- Emergency stop button
- Adjustable, anti-vibration machine feet
- Programmable automatic stop triggered by elapsed time or temperature limit
- Removable 3-knife head, optionally with 6 knives
- Knife lid assisted with pneumatic piston, automatic stop of the knives when opening lid watertight electric cabinet
- Strong, all stainless steel construction, solid s/s bowl and lid.



46215



46216

## 16 Qt Bowl Cutter 3 HP



Item	46215
Model	FP-ES-0015
Bowl Volume	16 qt ( 15 L)
Mixture Bowl Capacity (Approx.)	Soft Meat: 9 - 26 lb / 4 -12 kg Tough Meat: 9 - 18 lb / 4 - 8 kg
RPM	750-3000 RPM
Power	3 hp / 2,300 W
Amps	12.5 A
Electrical	225V / 60Hz / 1Ph
Net Weight	364 lb / 165 kg
Net Dimensions	25" x 36" x 22"
Optional Items	6-knife head, Single phase motor (1 speed-2.5 hp)

## 31 Qt Bowl Cutter 7.5 HP



Item	46216
Model	FP-ES-0030
Bowl Capacity	31 qt ( 30 L)
Mixture Bowl Capacity (Approx.)	Soft Meat: 11 - 48 lb5 - 22 kg Tough Meat: 11 - 33 lb / 5 - 15 kg
RPM	750-3000 RPM
Power	7.5 hp / 5,600 W
Amps	13.2 A
Electrical	208V / 60Hz / 3Ph
Net Weight	728 lb / 330 kg
Net Dimensions	37" x 41" x 62" (open lid)
Optional Items	6-knife head, Single phase motor (1 speed-2.5 hp)

# Super Heavy Duty

## Super Heavy Duty Bowl Cutter



### Super High Productivity

Bowl cutting produces as much as 15% higher finished product yield. These bowl cutters have numerous features that demonstrate their wide possibilities of use, both universal cutter and emulsifier, to produce fine and delicate pastes.

- Solid cast stainless steel bowl with a liquid drain cast
- Front guard protects spillage of liquids/dough
- Highly productive while efficient on power
- Fast cutting speeds and large bowl capacity
- Easy cleaning and maintenance
- Thermal protection on all motors
- Large openings to access the interior

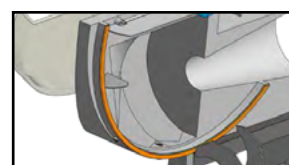

Removable lid/bowl friction band and bowl rim scraper

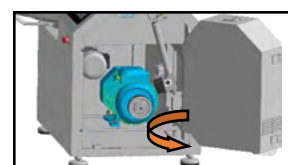

Large openings and folding electric distribution panel

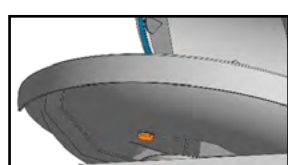

Bowl drain plug

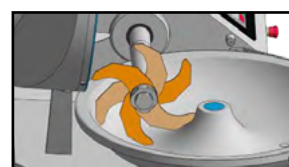

Knife head assembly: 6 or 3 knives

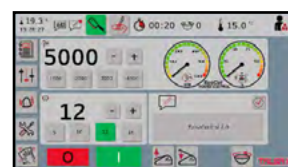

Digital control 15" touch screen

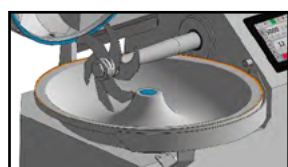

Elevated outer bowl rim



	58 qt (55 L) Bowl Volume	100 qt (95 L) Bowl Volume	143 qt (135 L) Bowl Volume
Item	47834	47835	47836
Model	FP-ES-0055	FP-ES-0095	FP-ES-0135
Bowl Volume	58 qt (55 L)	100 qt (95 L)	143 qt (135 L)
Mixture Bowl Capacity Approx.	88 lb (40 kg)	110 lb (50 kg)	155 lb (70 kg)
Machine Power	16.5 kW / 22.5 hp	25 kW / 34 hp	35 kW / 48 hp
Knife Motor Power	15 kW / 20.5 hp	22 kW / 30 hp	30 kW / 41 hp
Knife Speed (Variable)	500 - 5000 RPM		
Bowl Speed	4 - 20 RPM		
Electrical	220V / 60Hz / 3Ph		
Amps	63 A	100 A	125 A
Net Weight	1984 lb (900 kg)	3087 lb (1400 kg)	4409 lb (2000 kg)
Net Weight	1984 lb (900 kg)	3087 lb (1400 kg)	4409 lb (2000 kg)
Net Dimensions (WDH)	61.5" x 47" x 65.5" (1562 x 1194 x 1664 mm)	66" x 63" x 72" (1680 x 1420 x 1820 mm)	100" x 68" x 79" (2540 x 1730 x 2000 mm)
Gross Weight	2205 lb (1000 kg)	3307 lb (1500 kg)	4623 lb (2097 kg)
Gross Dimensions (WDH)	56" x 55" x 66"	85" x 71" x 73"	

# Meat Tenderizer



- Stainless-steel construction is corrosion resistant providing durability and appliance longevity
- The portable and user-friendly design is perfect for any countertop, allowing for simple operation
- Convertible safety cover made of transparent material is removable for cleaning
- Built-in Interlock for automatic shut-off to prevent hazardous machine
- Non-drip feet on the machine ensure stability on various surfaces, preventing tilt and hazardous situations
- Waterproof ON/OFF switch
- \* Tenderizing blade or strip cutter required for the machine

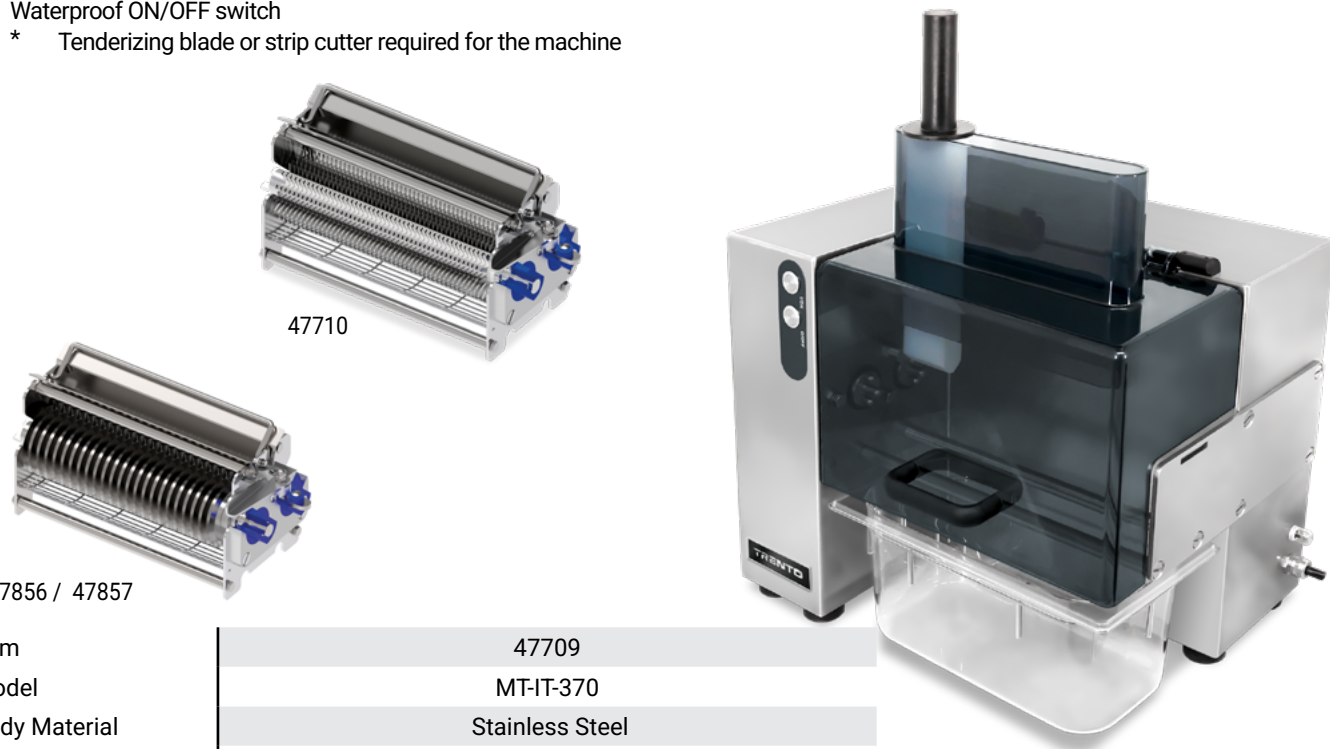

47856 / 47857

Item	47709
Model	MT-IT-370
Body Material	Stainless Steel
RPM	110
Power	370 W / 0.5 hp
Amps	6.4 A
Electrical	120V / 60Hz / 1Ph
Feed Opening Dimensions	10" x 1.18" (254 x 30 mm)
Net Weight	77 lb ( 35 kg)
Net Dimensions (WDH)	18" x 13.5" x 20"

Optional Item  
 47710 – Stainless Steel 96-Blade tenderizer cradle  
 47856 – 3/8" (10 mm) Fajita Meat Strip Cutter Cradle with 48 Blades for Electric Meat Tenderizer  
 47857 – 5/8" (15 mm) Fajita Meat Strip Cutter Cradle with 32 Blades for Electric Meat Tenderizer

# Meat Grinder

## #12 Grinder



- Manufactured with a polished aluminum body and stainless steel hopper
- Comes with 3/16" plate and European-style knife
- Ideally suited for restaurants or small butcher operations

Item	11051
Model	MG-IT-0012-C
Throat Opening	2" approx
Power	1.0 hp / 750 W
Electrical	110V / 60Hz / 1Ph
Net Weight	42 lb (19 kg)
Net Dimensions	16.25" x 8" x 17.5"



11051

## #22 Grinder



- Manufactured with a polished aluminum body and stainless steel hopper
- Comes with 3/16" plate and European-style knife
- Ideally suited for restaurants or small butcher operations

Item	11053
Model	MG-IT-0022-C
Throat Opening	2" approx
Power	1.5 hp / 1120 W
Electrical	110V / 60Hz / 1Ph
Net Weight	50 lb (22.73 kg)
Net Dimensions (WDH)	17" x 9" x 20"
Optional Attachment	Tomato Attachment (10103)



11053

## #22 Grinder Heavy Duty



- Overheating protection
- High quality stainless steel and produces 771 lb (350kg) of meat per hour
- Quiet and generates less heat
- Ideal for any restaurant, deli or small butcher shop

Item	46204
Model	MG-ES-0022
Power	1.5 hp / 1,100 W
Electrical	220V/ 60 Hz / 3Ph
Net Weight	110 lb (50 kg)
Net Dimensions (WDH)	23.7" x 12.2" x 18.2" (600 x 310 x 460 mm)



## #32 Grinder Heavy Duty



- Great value with a proven record of dependability and performance
- High quality stainless steel and produces 1320 lbs.(600 kg) of meat per hour
- Equipped with a safety micro switch, larger tray, hand protection
- High performance 1/4" plate and European-style knife
- Ideal for any restaurant, deli or small butcher shop

Item	39714
Model	MG-IT-0032-C
Throat Opening	2.75" / 69.85 mm
Power	3 hp / 2,200 W
Electrical	220V/ 60 Hz / 1Ph
Net Weight	114 lb (52 kg)
Net Dimensions (WDH)	22.5" x 11.8" x 22"



## Tomato Squeezer Attachments for Meat Grinder



Item	10103
Description	Tomato Attachment for #22 European Stainless Steel Meat Grinders (11053)
Gross Weight	7 lb (3.18 kg)
Gross Dimensions	12" x 12" x 12"

# Meat Mixers



## Heavy Duty Dual Paddle & Tilting

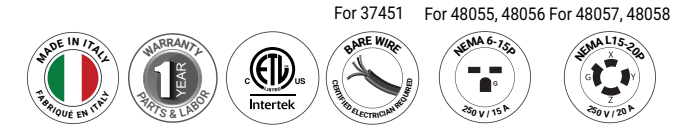

- Modern design and strong AISI 304 stainless steel construction
- Tilting tank with automatic locking system and safety lock
- Stainless steel swivel wheels with lock
- Two mixing arms system
- Removable AISI 304 stainless steel mixing arms (no tools required)
- Total protection of gear box/control panel
- Oil-bath gear box, ground and tempered helical gears
- Double seal on tank and gear box
- Stainless steel cover with safety micro-switch
- Minimum loading required: 40% max capacity
- Stainless steel IP 67 controls
- Perfect for hard mix and salad.

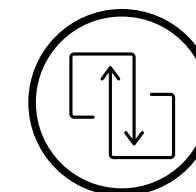

Toolless mixing arm removal ensures easy maintenance and cleaning

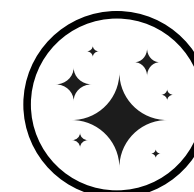

Modern clean design with AISI 304 stainless steel is both aesthetically pleasing to a clean kitchen, and ensures durability



Mobile design with casters make it easy to move the station to the ingredients when required

Selection on next page



## Heavy Duty Dual Paddle & Tilting

For 37451 For 48055, 48056 For 48057, 48058



	110 lb (50 kg) Capacity with 1 Phase	176 lb (80kg) Capacity with 1 Phase
Item	48055	48056
Model	MM-IT-0050-ETL	MM-IT-0080-ETL
Tank Capacity	23 Gal (88 L)	29 Gal (110 L)
Mixing Capacity	110 lb (50 kg)	176 lb (80 kg)
Power	0.5 HP / 370 W (x2)	0.75 HP / 550W (x2)
Electrical	220V / 60Hz / 1Ph	220V / 60Hz / 1Ph
Tank Dimensions	16.5" x 19.7"	24" x 20"
Net Weight	187 lb (85 kg)	198 lb (90 kg)
Net Dimensions (DWH)	25" x 32" x 41" (H = 64" open door)	25" x 39" x 41"



	265 lb (120kg) Capacity with 3 Phase	265 lb (120kg) Capacity with 3 Phase	397 lb (180kg) Capacity with 3 Phase
Item	37451	48057	48058
Model	MM-IT-0120	MM-IT-0120-ETL	MM-IT-0180-ETL
Tank Capacity	43 Gal (163 L)	43 Gal (163 L)	66 Gal (250 L)
Mixing Capacity	265 lb (120 kg)	265 lb (120 kg)	397 lb (180 kg)
Power	730 W / 1 hp (x2)	1 HP / 750W (x2)	0.75 HP / 550W (x2)
Electrical	220 V/ 60Hz/ 3Ph	220V / 60Hz / 3Ph	220V / 60Hz / 3Ph
Tank Dimensions	26" x 21.7"	26" x 21.7"	39.2" x 21.7"
Net Weight	304.2 lb (138 kg)	304.2 lbs. (138 kg)	335 lb (152 kg)
Net Dimensions (DWH)	27.6" x 43" x 47.6"	27.6" x 43" x 40.5"	27.6" x 56" x 47.6"

# Meat Slicers

Meat slicers are an important piece of equipment for any supermarket, deli or restaurant. Trento slicers are ideal for creating perfect cuts of meat, lettuce, tomatoes and other vegetables.

**Selection Guide on pg.241**

**Belt-Driven Slicers:**

- Uses a flexible belt to transfer power from the motor to the blade
- Generally quieter and smoother in operation.
- Better suited for lighter or occasional use.

**Gear-Driven Slicers:**

- Uses gears to directly transfer power from the motor to the blade.
- More robust and durable, suitable for heavy-duty slicing tasks.
- Often preferred for commercial applications with high-volume slicing needs.

**Vertical Feed Slicers:**

- Recommended for slicing fresh meat.
- Offer precise and homogeneous slicing.

**Gravity Feed Slicers:**

- Perfect for deli meats, etc.
- Designed to gently push the meat against the blade for consistent quick and easy slicing.

## Residential Line

### Berkel Home 250 Residential use only



- Can cut cured meats, cooked meat, fruit, vegetables and bread and cured fish meat and cured seafood
- It is not advisable to slice frozen products as doing so may damage the blade.
- Brings design back into your kitchen without compromising functionally and safety standards
- Chrome-plated steel blade delivers the perfect uniform slices, while reducing waste
- Absence of sharp edges allows for easy and quick cleaning



Item	47111	47113
Model	HSBGM0U000000	HSBGM0U00000N
Colour	Red	Black
Construction	Aluminum Alloy Casting	
Blade Size	9.8"	
Cut Thickness	0 - 0.78" / 0 - 20 mm	
Cut Size	Rectangular - 7.9" x 7.2"   Circular - 7.2"	
Cheese Slicing*	☐☐☐	
Slicing Volume+	< 30 mins	
Power	190 W	
Electrical	115V / 60Hz / 1Ph	
Net Weight	32 lb (14.5 kg)	
Net Dimensions (WDH)	13.4" x 17.7" x 13.9"	
Gross Weight	49lb (22kg)	
Gross Dimensions	29.5" x 19.5" x 17"	

# Gravity Feed Belt Driven

## 8" Belt-Driven Slicers

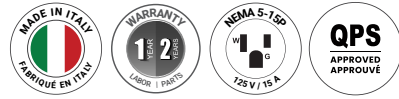

- Excellent for slicing vegetables and processed meats
- Compact design ideal for small operations where space is limited
- Perfect for delis, coffee shops and homes
- 13607 includes fixed blade sharpener
- Constructed of top quality anodized aluminum for durability and ease of cleaning.



13606



13607

	Removable Sharpener 0.2hp	Fixed Sharpener 0.2hp
Item	13606	13607
Model	MS-IT-0195	MS-IT-0195-S
Blade Size	8" / 195 mm	
Construction	Anodized Aluminum	
Cut Thickness	0 - 15 mm	
Cut Size	6.30" x 5.5"	
Cheese Slicing*	■□□	
Slicing Volume+	< 30 mins	
RPM	300	
Power	0.20 hp / 150 W	
Electrical	110V / 60Hz / 1Ph	
Net Weight	26 lb (12 kg)	
Net Dimensions (WDH)	20.5" x 14.17" x 12.40"	



Features

## 9" Belt-Driven Slicers



- Hard chromed high carbon steel blades, with a hollow ground taper - for extended sharpening and blade life
- Offers exceptional cutting consistency and durability
- The carriage moves smoothly on ball bearings allowing effortless cutting of deli meats and vegetables
- Perfect for low volume operations



13616



31342



	0.25hp	0.25hp
Item	13616	31342
Model	MS-IT-0220-UL	MS-IT-0220-C
Construction	Anodized Aluminum	Anodized Aluminum
Blade Size	9"/220 mm	9"/220 mm
Cut Thickness	0 - 15 mm	0 - 15 mm
Cut Size	8.25" x 6.05"	8.25" x 6.05"
Cheese Slicing*	□□□	■□□
Slicing Volume+	< 30 mins	< 30 mins
RPM	300	300
Power	0.25 hp / 190 W	0.25 hp / 190 W
Electrical	120V/ 60Hz / 1Ph	120V/ 60Hz / 1Ph
Net Weight	30 lb (13.5 kg)	30 lb (13.5 kg)
Net Dimensions (WDH)	22.83" x 16" x 13.40"	22.83" x 16" x 13.40"

Features



\*Cheese Slicing Ratings □□□ Not Recommended ■□□ Occasional ■□□ Low ■□□ Medium ■□□ High  
 \*Results may vary due to product consistency and temperature

# 10" Belt-Driven Compact Slicer



- Engineered with compact design compared to conventional 10" slicers.
- Larger blades allow for greater cutting capacity
- Perfect for slicing a variety of foods, these slicers are ideal for restaurants and sandwich shops



	0.25hp
Item	13623
Model	MS-IT-0250-IP
Blade Size	10"/250 mm
Construction	Anodized Aluminum
Cut Thickness	0 - 15 mm
Cut Size	8.25" X 6.30
Cheese Slicing*	□□□
Slicing Volume+	< 30 mins
RPM	300
Power	0.25 hp / 190 W
Electrical	120V/ 60Hz / 1Ph
Net Weight	30 lb (13.5 kg)
Net Dimensions (WDH)	22.83" X 16" X 13.40"

Features

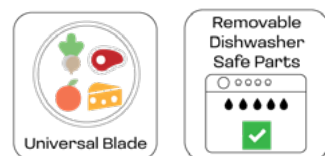

# 10" Belt-Driven Slicers



- Hard chromed high carbon steel blades, with a hollow ground taper - for extended sharpening and blade life
- Offers exceptional cutting consistency and durability
- The carriage moves smoothly on ball bearings allowing effortless cutting of deli meats and vegetables
- Perfect for low volume operations



13620



31343



	0.3hp	CE Professional 0.3hp
Item	13620	31343
Model	MS-IT-0250-U	MS-IT-0250-C
Construction	Anodized Aluminum	Anodized Aluminum
Blade Size	10" / 250 mm	10" / 250 mm
Cut Thickness	0 - 16 mm	0 - 16 mm
Cut Size	8.66" x 7.25"	8.66" x 7.25"
Cheese Slicing*	□□□	□□□
Slicing Volume+	45 mins	45 mins
RPM	300	300
Power	0.30 hp / 220 W	0.30 hp / 220 W
Electrical	120V/ 60Hz / 1Ph	120V / 60Hz / 1Ph
Net Weight	34 lb (15 kg)	34 lb (15 kg)
Net Dimensions (WDH)	25.6" x 19.5" x 17.3"	25.6" x 19.5" x 17.3"

Features



\*Cheese Slicing Ratings □□□□ Not Recommended □□□□ Occasional □□□□ Low □□□□ Medium □□□□ High  
 \*Results may vary due to product consistency and temperature

## 10" Belt-Driven Mid Volume Slicers

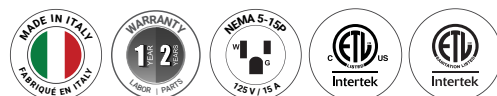

- Hard chromed high carbon steel blades, with a hollow ground taper - for extended sharpening and blade life
- Offers exceptional cutting consistency and durability
- The carriage moves smoothly on ball bearings allowing effortless cutting of deli meats and vegetables
- Perfect for low volume operations



Item	<b>0.35hp</b> 13621
Model	MS-IT-0250-I
Blade Size	10"/250 mm
Cut Thickness	0 - 15 mm
Cut Size	10.23" X 7.5"
Cheese Slicing*	■■■
Slicing Volume+	1 hour
RPM	300
Power	0.35 hp / 260 W
Electrical	110V / 60Hz / 1Ph
Net Weight	55 lb (25 kg)
Net Dimensions (WDH)	24.8" X 18.9" X 17.3"

## 11" Belt-Driven Slicers



- Hard chromed high carbon steel blades, with a hollow ground taper - for extended sharpening and blade life
- Offers exceptional cutting consistency and durability
- The carriage moves smoothly on ball bearings allowing effortless cutting of deli meats and vegetables
- Perfect for low volume operations



Item	<b>0.35hp</b> 13625
Model	MS-IT-0275-I
Blade Size	11" / 275 mm
Cut Thickness	0 - 15 mm
Cut Size	10.23" x 7.5"
Cheese Slicing*	■■■
Slicing Volume+	45 mins
RPM	300
Power	0.35 hp / 260 W
Electrical	110V / 60Hz / 1Ph
Net Weight	50 lb (22.6 kg)
Net Dimensions (WDH)	25.2" x 19.5" x 17.3"

Features



\*Cheese Slicing Ratings ■■■ Not Recommended ■■■ Occasional ■■■ Low ■■■ Medium ■■■ High  
\*Results may vary due to product consistency and temperature

## 12" Belt-Driven Compact Slicers

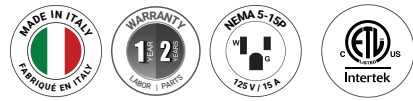

	0.35hp
Item	21624
Model	MS-IT-0300-I
Blade Size	12" / 300 mm
Construction	Anodized Aluminum
Cut Thickness	0 - 16 mm
Cut Size	8.66" x 7.5"
Cheese Slicing*	■ ■ ■
Slicing Volume+	1 hour
RPM	300
Power	0.32 hp / 246W
Electrical	120V / 60Hz / 1Ph
Net Weight	43.8 lb (19.9 kg)
Net Dimensions (WDH)	17.7" x 12.8" x 19.7"

Features

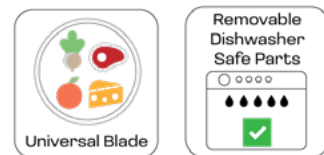

## 12" Belt-Driven Standard Slicers



13628



31344

	0.35hp	0.35hp
Item	13628	31344
Model	MS-IT-300-U	MS-IT-0300-C
Blade Size	12" / 300 mm	12" / 300 mm
Construction	Anodized Aluminum	Anodized Aluminum
Cut Thickness	0 - 16 mm	0 - 16 mm
Cut Size	10.23" x 8.41"	10.23" x 8.41"
Cheese Slicing*	■ ■ ■	■ ■ ■
Slicing Volume+	1 hour	1 hour
RPM	300	300
Power	0.35 hp / 200 W	0.35 hp / 200 W
Electrical	120V / 60Hz / 1Ph	120V / 60Hz / 1Ph
Net Weight	50 lb (23 kg)	50 lb (23 kg)
Net Dimensions (WDH)	25.60" x 19.5" x 17.32"	25.60" x 19.5" x 17.32"

Features

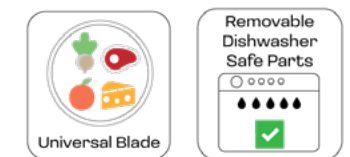

\*Cheese Slicing Ratings ■ ■ ■ Not Recommended ■ ■ ■ Occasional ■ ■ ■ Low ■ ■ ■ Medium ■ ■ ■ High  
 \*Results may vary due to product consistency and temperature

# 12/13/14" Heavy Duty Belt-Driven Slicers



- High horsepower motors and dependable belt drives
- Suited for sub shops, supermarkets, and demanding restaurant applications



13629



13635



13637

	0.5hp 12"	0.5hp 13"	0.5hp 14"
Item	13629*	13635	13637
Model	MS-IT-300-IP	MS-IT-0330-L	MS-IT-0350-L
Construction	Anodized Aluminum	Anodized Aluminum	Anodized Aluminum
Blade Size	12"/300 mm	13" / 330 mm	14"/350 mm
Cut Thickness	0 - 16 mm	0 -16 mm	0 -16 mm
Cut Size	11.25" x 9"	11.25" x 9.84"	12.75" x 10.25"
Cheese Slicing*	Low	Low	Low
Slicing Volume+	4 hours	4 hours	4 hours
RPM	280	280	286
Power	0.50 hp / 300 W	0.50 hp / 370 W	0.50 hp / 370 W
Electrical	110V / 60Hz / 1Ph	110V / 60Hz / 1Ph	110V / 60Hz / 1Ph
Net Weight	79.3 lb (36 kg)	85 lb (38.5 kg)	97 lb (44 kg)
Net Dimensions (WDH)	30.3" x 21.25" x 18.3"	30.3" x 21.65" x 18.3"	22.83" x 23" x 19"
Gross Weight	84 lb (38 kg)	86 lb (39 kg)	104 lb (47 kg)
Gross Dimensions	28" x 25" x 21"	28" x 25" x 21"	29" x 32" x 22"



Features

# Gear Driven Gravity Feed

## 12/13/14" Heavy Duty Gear-Driven Slicers



- Provides long lasting heavy-duty performance and dependability
- Gears are constantly bathed in oil
- Polished anodized aluminum body with high carbon, hard chromed blade
- Easy to disassemble and clean
- Suitable for cheese and hard meats



13641

	0.35hp 12"	0.35hp 13"	0.35hp 14"
Item	13641	13642	13643
Model	C300/N	C330/N	C350/N
Construction	Anodized Aluminum	Anodized Aluminum	Anodized Aluminum
Blade Size	12"/300mm	13"/330mm	14"/350mm
Cut Thickness	0-14 mm	0-14 mm	0-14 mm
Cut Size	5.9" x 9.8"	6.5" x 10.62"	7.28" x 11.42"
Cheese Slicing*	Low	Low	Low
Slicing Volume+	8 hours or more	8 hours or more	8 hours or more
RPM	250	250	250
Power	0.35 hp / 260 W	0.35 hp / 260 W	0.35 hp / 260 W
Electrical	110V / 60Hz / 1Ph	110V / 60Hz / 1Ph	110V / 60Hz / 1Ph
Net Weight	95 lb (43 kg)	99 lb (45 kg)	100 lb /45 kg)
Net Dimensions (WDH)	28.3" x 22.4" x 20"	28.75" x 24" x 20"	30" x 24.8" x 20"

\*Cheese Slicing Ratings: Not Recommended, Occasional, Low, Medium, High  
 \*Results may vary due to product consistency and temperature

# 13" Gear-Driven Heavy Duty Slicers



- ON/OFF one touch stainless steel switches with LED flush with slicer casting
- Removable parts for cleaning: blade cover, product-holder plate, aluminum meat grip, stainless steel slice deflector
- Blade with narrow band of chromium - plated hardened steel
- Readily removable transparent Plexiglas Protection on product - holder plate
- Interlock on gauge plate on zero position



	0.47hp	0.47hp	0.48 hp
Item	31438	38917	48391
Model	C330/N	C330/N	MS-IT-0330
Construction	Aluminum and Stainless Steel	Aluminum and Stainless Steel	Aluminum and Stainless Steel
Blade Size	13" / 330 mm	13" / 330 mm	13" / 330 mm
Cut Thickness	0 - 0.55" / 0 -14 mm	0 - 0.55" / 0 -14 mm	0-0.94" (0-24 mm)
Cut Size	Rectangular - 10.6" x 6.7" Circular - 9.45"	Rectangular - 10.6" x 6.7" Circular - 9.45"	Rectangular 11.4 x 8.3" Circular 9.45"
Cheese Slicing*	Low	Low	Low
Slicing Volume+	All Day	All Day	All Day
RPM	240	240	255
Power	0.47 hp / 350 W	0.47 hp / 350 W	0.48 hp / 360 W
Electrical	120V / 60Hz / 1Ph	120V / 60Hz / 1Ph	120V / 60Hz / 1Ph
Net Weight	95 lb (43 kg)	95 lb (43 kg)	105 lb (48 kg)
Net Dimensions (WDH)	26.38" x 29.7" x 20.87"	26.38" x 28.7" x 20.87"	24.5" x 31.2" x 25.4"

# Automatic Gravity Feed

## 12" Automatic Belt-Driven Gravity Feed Slicers

Safety options available.



- Equipped with two separated fan-cooled motors: one operating the blade, the other one operating the carriage, removable sharpener, fixed blade ring guard, and removable product holder
- Crafted with anodized aluminum alloy and a tempered chromium steel blade
- Adjustable carriage stroke and available options
- Has removable aluminum blade cover, product holder, pusher, and stainless steel slice deflector



	2x0.5hp
Item	13654
Model	GLMATIC300/N
Construction	Anodized Aluminum
Blade Size	12"/300mm
Cut Thickness	0-14 mm
Cut Size	8.85" x 8.66"
Cheese Slicing*	Low
Slicing Volume+	8 hours or more
RPM	200
Power	2 x 0.50 hp / 370 W
Electrical	120V / 60Hz / 1Ph
Net Weight	90 lb (41 kg)
Net Dimensions (WDH)	25.19" x 21.65" x 20.86"

\*Cheese Slicing Ratings: Not Recommended, Occasional, Low, Medium, High  
 \*Results may vary due to product consistency and temperature

# 13" Automatic Gear-Driven Slicers

Safety options available



- Silent gear transmission
- Separate cutting and carriage motors
- Auto carriage return
- Built in sharpener and fixed outer blade cover ring
- Lubricating point device for sliding bar
- Easy to disassemble and clean



39477



13645



	0.6 hp	2x 0.5hp
Item	39477	13645
Model	CXMAT330/N	CXMATIC330/N
Construction	Anodized Aluminum	Anodized Aluminum
Blade Size	13" / 330 mm	13" / 330mm
Cut Thickness	0 - 0.55" / 0 -14 mm	0 - 0.55" / 0 -14 mm
Cut Size	Rectangular - 10.2"x 6.7" Circular - 9.25"	Rectangular - 10.2" x 6.69" Circular - 9.25"
Cheese Slicing*		
Slicing Volume+	8 hours or more	8 hours or more
RPM	240	240
Power	0.60 hp / 450 W	2 x 0.50 hp / 370 W
Electrical	120V / 60Hz / 1Ph	120V / 60Hz / 1Ph
Net Weight	130 lb (69 kg)	123.5 lb (56 kg)
Net Dimensions (WDH)	25.6" x 28.7" x 24.4"	25.6" x 28.7" x 24.4"

# Vertical Feed Horizontal Carriage

## Vertical Belt-Driven Slicers



- Made of anodized aluminum alloy which makes it easy to clean and meet the most demanding sanitation requirements
- Precise decimal thickness regulator ranges between 0 and 16 mm
- Equipped with a built-in blade sharpener for effective cutting
- Plate mounted on the ball bearings creates an exceptionally smooth operation
- Ideal for thin prosciutto slicing



	12", 0.5hp	13", 0.5hp	14", 0.5hp	14.5", 0.5hp
Item	46162	46163	39583	39584
Model	MS-IT-0300-CE	MS-IT-0330-CE	MS-IT-0350	MS-IT-0370-V
Construction	Anodized Aluminum			
Blade Size	12"/300 mm	13" / 330 mm	14"/ 350 mm	14.5"/ 370 mm
Cut Thickness	0-16mm			
Cut Size	10" x 8.7"	10" x 8.7"	11.81" x 10.43"	11.42" x 10.82"
Cheese Slicing*	-	-	-	-
Slicing Volume+	4 hours	4 hours	4 hours	4 hours
RPM	280	260	260	260
Power	0.50 hp / 370 W			
Electrical	110V / 60Hz / 1Ph			
Net Weight	75 lb (34 kg)	75 lb (34 kg)	99 lb (45 kg)	101 (46 kg)
Net Dimensions (WDH)	21.7" x 28" x 21.7"	21.7" x 28" x 21.7"	32.28" x 25.6" x 25.19	32.28" x 25.6" x 25.19

\*Cheese Slicing Ratings Not Recommended Occasional Low Medium High  
 \*Results may vary due to product consistency and temperature

# S Series Vertical Belt-Driven Slicers



The "S" Series Slicers are specially designed to cut fresh meat. The large horizontal carriage has a double sliding table designed to cut fresh meat by providing a long stroke depth.

- Superglide: Specially treated gauge-plate and blade cover for a smoother performance that ensures precision cuts at all times
- Additional safeties: Fixed blade ring guard; aluminum thumb guard; interlock for carriage disassembly; NVR (No Voltage Release) switch and protections on the sharpener and blade



44006

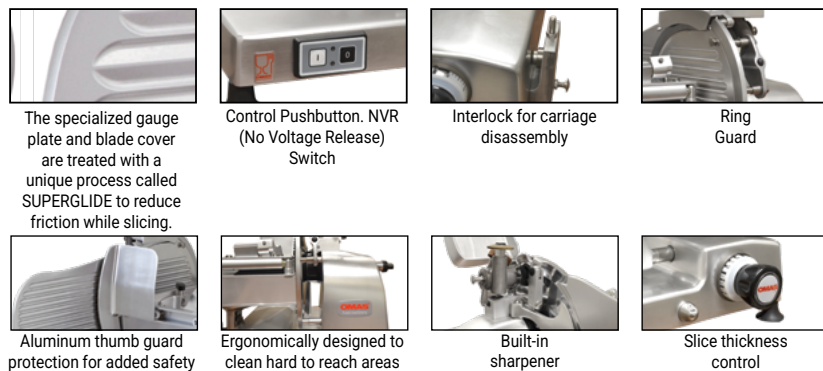

The specialized gauge plate and blade cover are treated with a unique process called SUPERGLIDE to reduce friction while slicing.

Control Pushbutton. NVR (No Voltage Release) Switch

Interlock for carriage disassembly

Ring Guard

Aluminum thumb guard protection for added safety

Ergonomically designed to clean hard to reach areas

Built-in sharpener

Slice thickness control



39631

Item	12.3"	14"
Item	44006	39631
Model	H313	H350/N
Construction	Anodized Aluminum	Anodized Aluminum
Blade Size	12.3" / 313 mm	14" / 350 mm
Cut Thickness	0-25 mm	0-25 mm
Cut Size	10.63" x 8.86"	12.20" x 9.84"
Cheese Slicing*	-	-
Slicing Volume*	All Day	All Day
RPM	250	250
Power	0.40 hp / 300 W	0.40 hp / 300 W
Electrical	110V / 60Hz / 1Ph	110V / 60Hz / 1Ph
Net Weight	84 lb (38 kg)	110 lb (50 kg)
Net Dimensions (WDH)	29" x 26" x 20"	26" x 28" x 21.7"

# 15" Vertical Gear-Driven Slicers



- New design: rounded and enlarged receiving surface
- Removable carriage, end grip and blade cover for easy cleaning
- Anodized aluminum alloy construction
- Superglide: Specially treated gauge-plate and blade cover for a smoother performance that ensures precision cuts at all times
- Additional safety features: Fixed blade ring guard; aluminum thumb guard; Interlock For Carriage Disassembly; NVR (No Voltage Release) switch and protections on the sharpener and blade



38915



49532

	Red	Silver
Item	49532	38915
Model	H370/N RED	H370/N
Construction	Anodized Aluminum	
Blade Size	15" / 370 mm	
Cut Thickness	0-25mm	
Cut Size	14.56" x 10.23"	
Cheese Slicing*	-	-
Slicing Volume+	All Day	
RPM	250	
Power	0.40 hp / 300 W	
Electrical	110V / 60Hz / 1Ph	
Net Weight	125 lb (58 kg)	
Net Dimensions (WDH)	31.5" x 29.5" x 22"	

\*Cheese Slicing Ratings: Not Recommended Occasional Low Medium High  
 \*Results may vary due to product consistency and temperature



# VINTAGE LOOK

---

# MODERN TECHNOLOGY

Circa 1919, Volano slicer was designed by reaching a perfect balance between style, craftsmanship, passion, and cutting edge manufacturing techniques. The vintage look offers a sense of tradition with a touch of modern technology.

The classic Volano slicers feature a removable stainless steel cover tray, comb pusher and receiving tray which makes washing and

sanitizing easy. The wide space between the blade and the slicer body provides easy access when cleaning.

The slicer comes with a shift-able 360° blade guard, covering the entire blade, designed for safety while not compromising performance. The machine is equipped with a professional heavy duty sharpener, which ensures the blade stays sharp on every use.

# OMAS

Food technology  
solutions

## Volano Heritage Manual Slicer



Item	44007
Model	HERITAGE
Blade Size	12 1/2" / 319 mm
Cut Thickness Range	0.3 - 4 mm
Cut Size	8" x 8.66"
Net Weight	110 lb (50 kg)
Net Dimensions (WDH)	32.7" x 23" x 22"



## Volano Slicer with Standard Flywheel



46088



360° shift-able  
blade guard  
for safety



Stainless steel  
comb pusher  
for durability



Removable  
stainless steel  
slice receiving  
tray for total  
hygiene



Item	Manual Slicer 46088	14.5" Volano Automatic 47706	14.5" Volano Semi-Automatic 47707
Model	S37	SE9 37E	S9M
Blade Size	14.5" (370 mm)		
Cut Thickness Range	0 mm - 4 mm	0 - 0.25" (0 - 7 mm)	
Cut Size	11.4" x 10.2" (Dia 10.2")	11.5" x 10" (292 x 254 mm)	
Power	-	746 W / 1 hp	
Electrical	-	120V / 60Hz / 1Ph	
Net Weight	176 lb (80 kg)	305 lb (138 kg)	
Net Dimensions (WDH)	31.1" x 39" x 27"	39" x 31" x 28.5" (990 x 787 x 723 mm)	

# Volano Luxury Edition



- Designed in brilliant red with nostalgic appeal
- Fully hand operated, simple to maintain and operate
- Durable and consistent slicing
- Built-in blade sharpener keeps the blade sharp for efficient cutting
- Other flywheel and trim colors are available as special order
- Machines also available in different colors
- Designed for precise slicing of fine meat & prosciuttos
- Luxury trim in gold/silver running across body

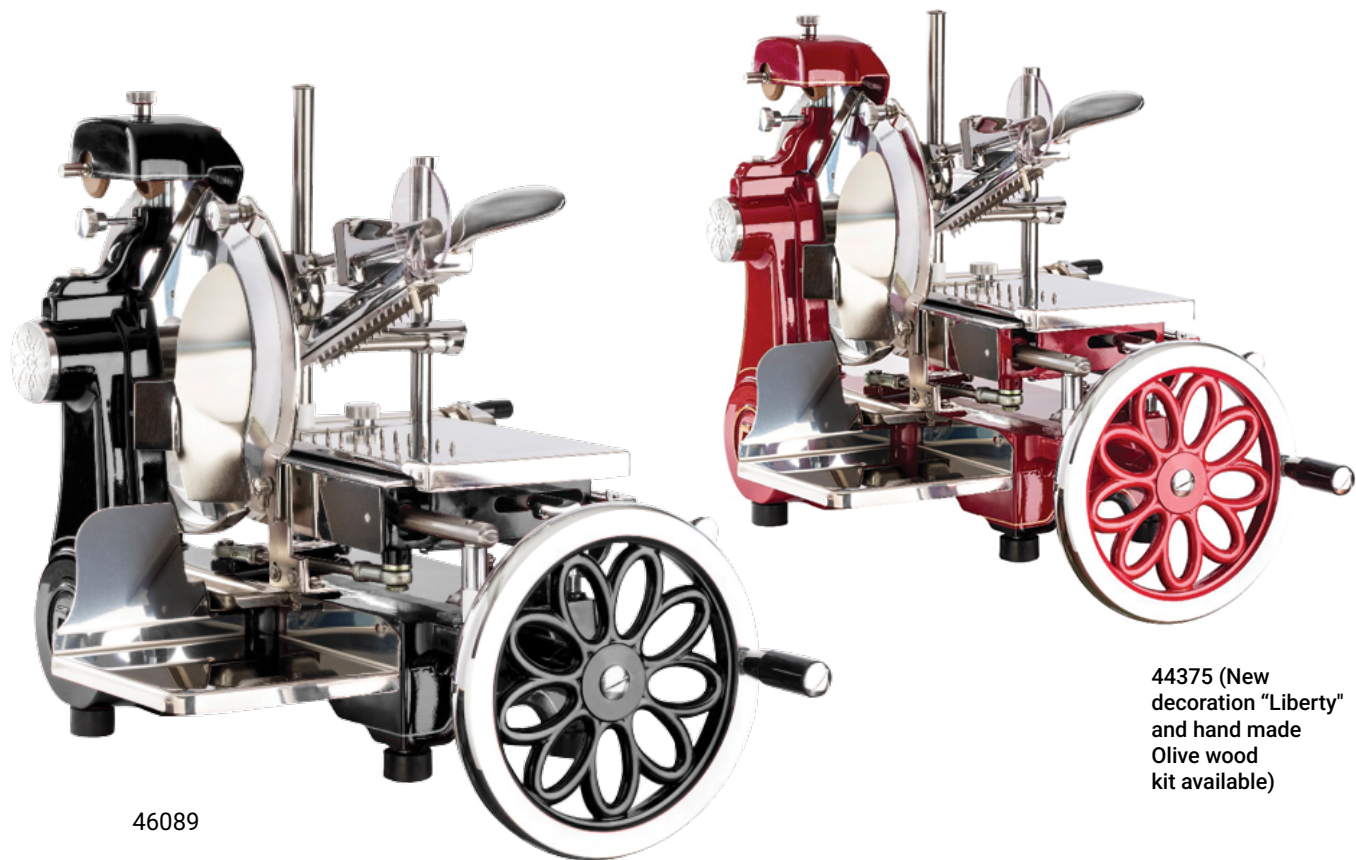

44375 (New decoration "Liberty" and hand made Olive wood kit available)

46089

	12" Luxury Black	12" Luxury Red
Item	46089	44375
Model	MS-IT-0300-BF	MS-IT-0300-ML
Blade Size	12"/300 mm	12" / 300 mm
Cut Thickness	0-2.5 mm	0-2.5 mm
Cut Size	9" x 7"	9" x 7"
Net Weight	100 lb (45 kg)	97 lb (44 kg)
Gross Weight	143 lb (65 kg)	100 lb (45 kg)
Gross Dimensions	31.5" x 29" x 39"	25" x 31.5" x 27.6"

# Volano Manual Slicer with Daisy Flywheel



	10"	12"	14"	14.5"
Item	26072	26073	26074	20387
Model	MS-IT-0250-MF	MS-IT-0300-MF	MS-IT-0350-MF	MS-IT-0370-MF
Blade Size	10" / 250 mm	12" / 300 mm	14"/350 mm	14.5" /370 mm
Cut Thickness	0-2 mm	0-2 mm	0-2.5 mm	0-2.5 mm
Cut Size	7.30" x 5.90"	9" x 7.5"	10.62" x 9.44"	10.62" x 9.84"
Net Weight	72.6 lb (33 kg)	100 lb (45.35 kg)	178 lb (81 kg)	178 lb (81 kg)
Gross Weight	99 lb (45 kg)	169 lb (76.6 kg)	228 lb (103 kg)	220 lb (100 kg)
Gross Dimensions	32" x 26" x 28"	30" x 30" x 27"	37" x 37" x 34"	37" x 33" x 38"

# Volano Manual Slicer with Standard Flywheel







**Customizable Flywheel & Color**



20013



13639 & 18987

	10"	12"	14"	14.5"
Item	 20013	 13634	 13639	 18830
Model	MS-IT-0250-M	MS-IT-0300-M	MS-IT-0350-M	MS-IT-0370-M
Blade Size	10"/250 mm	12"/300 mm	14"/350 mm	14.5"/370 mm
Cut Thickness	0-2 mm	0-2 mm	0-2.5 mm	0-2.5 mm
Cut Size	7.30" x 5.90"	9" x 7.5"	10.62" x 9.44"	10.62" x 9.84"
Net Weight	72.6 lb (33 kg)	100 lb (45 kg)	178 lb (81 kg)	178 lb (81 kg)
Gross Weight	100 lb (45 kg)	116 lb (53 kg)	234 lb (106 kg)	234 lb (106 kg)
Gross Dimensions	30" x 26" x 27"	30" x 26" x 28"	37" x 33" x 38"	37" x 33" x 38"

## Pedestal Stands

### Without Wheels

Item	Description	Compatible Item(s)
20014	Red Pedestal Stand	20013 and 26072
18986	Red Pedestal Stand	13634 and 26073
18987	Red Pedestal Stand	13639, 18830, 26074 and 20387
46134	Red Pedestal Stand	46088
45304	Red Pedestal Stand	44007



20014/18986/18987



46134



45304

### With Wheels



46336  
(Stand with wheel)

Item	Description	Compatible Item(s)
46336	Red Pedestal Stand with wheels	26074, 20387, 13639 and 18830
46337	Red stand with wheels	26072, 26073, 44375, 46089, 20013, 13634, 46131 and 44375
45983	Black stand with wheels	26074, 20387, 13639 and 18830

### Flywheel Style: Standard

Selection specific to Non-OMAS units  
For OMAS units, please inquire

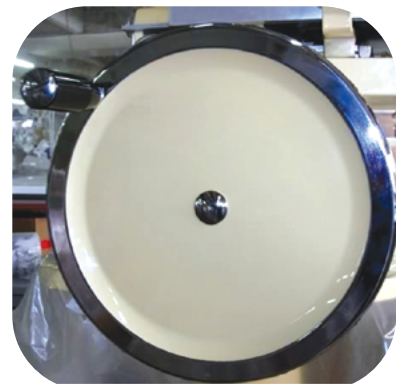

White



Black



Red

### Flywheel Style: Daisy Plain



Red



Black



Green

### Flywheel Style: Rosette



White



Red



Blue



Black

### Flywheel Style: Daisy Trimmed



Red with Gold Trim



Black with Gold Trim



Wine Red with Silver Trim



Silver with Black Trim

# COMPREHENSIVE SELECTION GUIDE

(Does not include Volano slicers)

## 1. What types of foods can I slice with a meat slicer?

Meat slicers can slice a variety of foods, primarily used for meats (such as deli meats, roasts, and turkey), but can also be used for cheeses, vegetables, and more.

## 2. How do I choose the right meat slicer for my needs?

Consider factors like the type of food you plan to slice, the volume of slicing you'll do, and the available space in your kitchen. Choose a slicer with the appropriate blade size and power for your requirements.

## 3. What is the importance of adjustable slicing thickness?

Adjustable thickness settings allow you to customize the thickness of your slices. Look for a slicer with easy-to-adjust thickness controls for versatility in your slicing tasks.

## 4. What is the difference between manual and automatic meat slicers?

Manual meat slicers require you to manually move the carriage back and forth, while automatic slicers have a motor that does the work for you. Automatic slicers are more suitable for high-volume slicing.

## 5. What's the difference between belt-driven and gear-driven meat slicers?

### Belt-Driven Slicers:

- Use a flexible belt to transfer power from the motor to the blade
- Generally quieter and smoother in operation.
- Better suited for lighter or occasional use.

### Gear-Driven Slicers:

- Use gears to directly transfer power from the motor to the blade.
- More robust and durable, suitable for heavy-duty slicing tasks.
- Often preferred for commercial with high-volume slicing needs.

## 6. What is the difference between vertical and gravity feed meat slicers?

### Vertical Feed Slicers:

- Recommended for slicing fresh meat.
- Offer precise and homogeneous slicing.

### Gravity Feed Slicers:

- Perfect for deli meats, etc.
- Designed to gently push the meat against the blade for consistent quick and easy slicing.

Item	44264
Description	Meat Slicer Cover, 100% Cotton made cover for 8" or 9" blade sizes meat slicers

Item	Blade Size	Type	Power	Slicing Volume	Cheese Slicing	Drive Type	Construction
Residential Line							
47111	10"	Red Colour, cETLus	0.25 hp	< 30 mins		Belt	Aluminum Alloy Casting
47113	10"	Black Colour, cETLus	0.25 hp	< 30 mins		Belt	Aluminum Alloy Casting

\*Cheese Slicing Ratings Not Recommended Occasional Low Medium High  
 \*Results may vary due to product consistency and temperature

Item	Blade Size	Type	Power	Slicing Volume	Cheese Slicing	Drive Type	Construction
Belt-Driven Gravity Feed Manual Slicers							
13606	8"	Removable Blade Sharpener, QPS	0.20 hp	< 30 mins		Belt	Anodized Aluminum
13607	8"	QPS, Fixed Blade Sharpener, QPS	0.20 hp	< 30 mins		Belt	Anodized Aluminum
13616	9"	cETLus, ETL Sanitation	0.25 hp	< 30 mins		Belt	Anodized Aluminum
31342	9"	Quebec Safety Standards,	0.25 hp	< 30 mins		Belt	Anodized Aluminum
13623	10"	Compact Body, cETLus	0.25 hp	< 30 mins		Belt	Anodized Aluminum
13620	10"	cETLus, ETL Sanitation	0.30 hp	45 mins		Belt	Anodized Aluminum
31343	10"	Quebec Safety Standards	0.30 hp	45 mins		Belt	Anodized Aluminum
13621	10"	Medium-Duty, cETLus	0.35 hp	1 hour		Belt	Anodized Aluminum
13625	11"	Medium-Duty, cETLus	0.35 hp	1 hour		Belt	Anodized Aluminum
21624	12"	Compact Body, cETLus	0.32 hp	1 hour		Belt	Anodized Aluminum
13628	12"	cETLus, ETL Sanitation	0.35 hp	1 hour		Belt	Anodized Aluminum
31344	12"	Quebec Safety Standards	0.35 hp	1 hour		Belt	Anodized Aluminum
13629	12"	Medium-Duty, cETLus	0.50 hp	4 hours		Belt	Anodized Aluminum
13635	13"	Medium-Duty, cETLus	0.50 hp	4 hours		Belt	Anodized Aluminum
13637	14"	Medium-Duty, cETLus	0.50 hp	4 hours		Belt	Anodized Aluminum

Gear-Driven Gravity Feed Manual Slicers							
13641	12"	Heavy-Duty, cETLus,	0.35 hp	All Day		Gear	Anodized Aluminum
13642	13"	Heavy-Duty, cETLus,	0.35 hp	All Day		Gear	Anodized Aluminum
13643	14"	Heavy-Duty, cETLus,	0.35 hp	All Day		Gear	Anodized Aluminum
31438	13"	Extra Heavy-Duty, cETLus	0.47 hp	All Day		Gear	Aluminum and Stainless Steel
38917	13"	Extra Heavy-Duty, NSF, cETLus	0.47 hp	All Day		Gear	Aluminum and Stainless Steel

Automatic Slicers Gravity Feed							
13654	12"	cETLus, NSF	2 x 0.50 hp	All Day		Belt	Anodized Aluminum
39477	13"	cETLus, In compliance with Province of Quebec safety standards,	0.60 hp	All Day		Gear	Anodized Aluminum
13645	13"	cETLus	2 x 0.50 hp	All Day		Gear	Anodized Aluminum

Vertical Feed Slicers with Horizontal Meat Carriage							
46162	12"	cETLus	0.5 hp	4 Hours	-	Belt	Anodized Aluminum
46163	13"	cETLus	0.5 hp	4 Hours	-	Belt	Anodized Aluminum
39583	14"	cETLus	0.5 hp	4 Hours	-	Belt	Anodized Aluminum
39584	14.5"	cETLus	0.5 hp	4 Hours	-	Belt	Anodized Aluminum
44006	12.3"	cETLus	0.4 hp	All Day	-	Gear	Anodized Aluminum
39631	14"	Quebec Safety Standards, cETLus	0.4 hp	All Day	-	Gear	Anodized Aluminum
49532	15"	Red Colour, Quebec Safety Standards, cETLus	0.4 hp	All Day	-	Gear	Anodized Aluminum
38915	15"	Silver Colour, Quebec Safety Standards, cETLus	0.4 hp	All Day	-	Gear	Anodized Aluminum

# Sausage Stuffers

## Manual Sausage Stuffer 2 Speed Horizontal Drive



This manual sausage stuffer offers a wide selection of sizes and configurations for residential and commercial applications. It has enameled steel sides. Supplied with a selection of stuffing funnels.



48160



48162 / 48163



48164 / 48165



47715 / 48161



48166

	3 L / 3 kg Direct Drive	5 L / 5 kg Gear Drive	7 L / 7 kg Direct Drive	10 L / 10 kg Direct Drive	12 L / 12 kg Direct Drive
Item	48160	47715	48161	48162	48163
Color	Red	Red	Red	Red	Red
Capacity	3 L / 3 kg	5 L / 5 kg	7 L / 7 kg	10 L / 10 kg	12 L / 12 kg
Funnel Size (mm)	15/23/28/38 mm				
Net Weight	19.2 lb (8.7 kg)	23.1 lb (10.5 kg)	26.2 lb (11.9 kg)	42.8 lb (19.4 kg)	46.3 lb (21 kg)
Net Dimensions (DWH)	25.6" x 13" x 7.9"	30.1" x 13" x 7.9"	34.1" x 13" x 7.9"	37" x 15.7" x 9.1"	40.9" x 15.7" x 9.1"

	5 L / 5 kg Gear Drive	7 L / 7 kg Gear Drive	10 L / 10 kg Gear Drive
Item	48164	48165	48166
Color	Stainless Steel	Stainless Steel	Stainless Steel
Capacity	5 L / 5 kg	7 L / 7 kg	10 L / 10 kg
Funnel Size (mm)	15/23/28/38 mm		
Net Weight	23.1 lb (10.5 kg)	26.2 lb (11.9 kg)	42.8 lb (19.4 kg)
Net Dimensions (DWH)	30.1" x 13" x 7.9"	34.1" x 13" x 7.9"	37" x 15.7" x 9.1"

# Manual Sausage Stuffer Gear Driven 2 Speed Vertical Drive



48167



47716



48168



48169



48170

	5 L / 5 kg Vertical Gear Drive	5 L / 5 kg Ver-tical and Hor-izontal Gear Drive	7 L / 7 kg Ver-tical and Hor-izontal Gear Drive	10 L / 10 kg Vertical and Horizontal Gear Drive	15 L / 15 kg Vertical and Horizontal Gear Drive
Item	48167	47716	48168	48169	48170
Color	Red	Stainless Steel	Stainless Steel	Stainless Steel	Stainless Steel
Capacity	5 L / 5 kg	5 L / 5 kg	7 L / 7 kg	10 L / 10 kg	15 L / 15 kg
Funnel Size ( mm)	15, 23, 28, 38 mm				
Net Weight	31 lb (14 kg)	30.9 lb (14 kg)	33.5 lb (15.2 kg)	52.9 lb (24 kg)	69.4 lb (31.5 kg)
Net Dimensions (DWH)	15.7" x 12.2" x 27.6"	15.7" x 12.2" x 27.6"	15.7" x 12.2" x 31.1"	17.3" x 12.2" x 33.9"	18.1" x 12.2" x 43.3"

# Electric Sausage Stuffer 33 lbs. (15L)



	15 L / 33 lb Pedal Operated
Item	48309
Color	Gray
Capacity	33 lb (15L)
Funnel Size (mm)	15/23/28/38 mm
Power	200 W
Electricals	110V/60Hz/1ph
Net Weight	77 lb (35 kg)
Net Dimensions (DWH)	11" x 13" x 32"

# Heavy Duty Hydraulic Stuffers



- 2 wheels and handle for easy transport
- Easily accessible speed control
- Pressure gauge
- Removable lid; adjustable lock nuts with handle
- Independent hydraulic oil reservoir
- Thermal protected motor
- Automatic knee lever lock until the piston reaches the lower position



Robust stainless steel construction



Cylinder ram in stainless steel

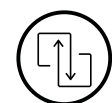

Easily removable piston



Built-in mobile design allows free movement

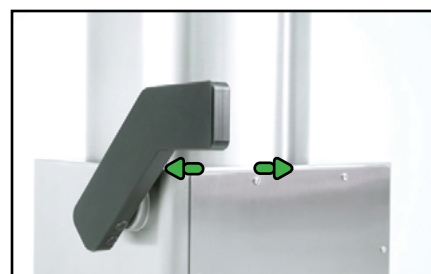

Ergonomic knee lever  
Reversible operating direction



Removable lid, adjustable lid lock nuts with handles



Speed control & pressure gauge



3 transparent nozzles,  $\phi$  ext 14, 20 and 30 mm. Maximum hygiene, without edges

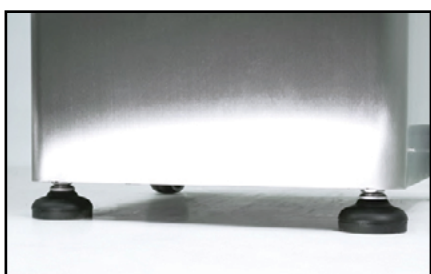

Adjustable anti-vibration feet



Fully s/s barrel bottom with water draining outlet. Simple cleaning.

## 26 lb Capacity

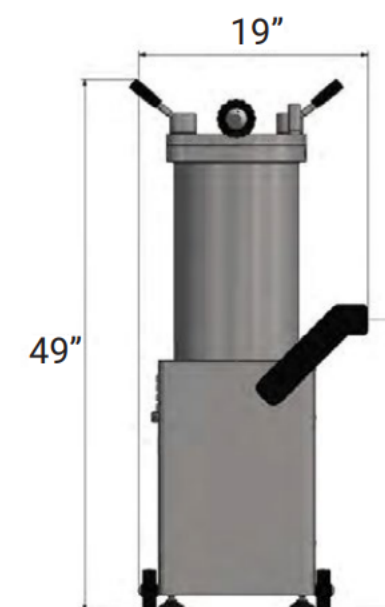
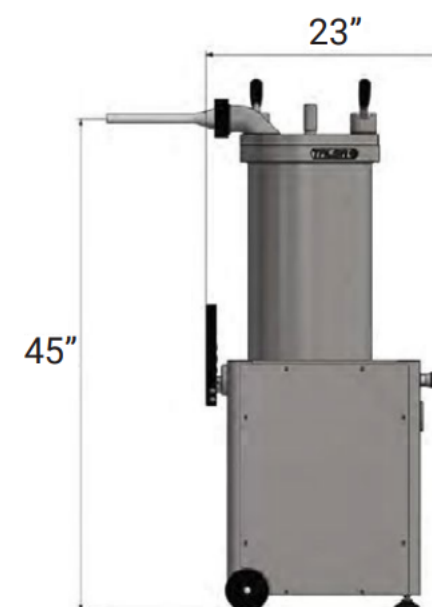

Item	45950	46098	46099
Model	SS-ES-0026-F	SS-ES-0026-FS	SS-ES-0026-FT
Approx. Meat Capacity	26 lb (12 kg)		
Barrel Capacity	15 qt (14.2 L)		
Operating Temperature	5° - 40° C (40° - 100° F)		
Power	1 hp / 750 W		0.75 hp / 550W
Amps	11 A	5 A	3.6 A
Electrical	110V / 60Hz / 1Ph	220V / 60Hz / 1Ph	208V / 60Hz / 3Ph
Net Weight	265 lb (120 kg)		
Net Dimensions (WDH)	21" x 19" x 49"		





**48 lb Capacity**

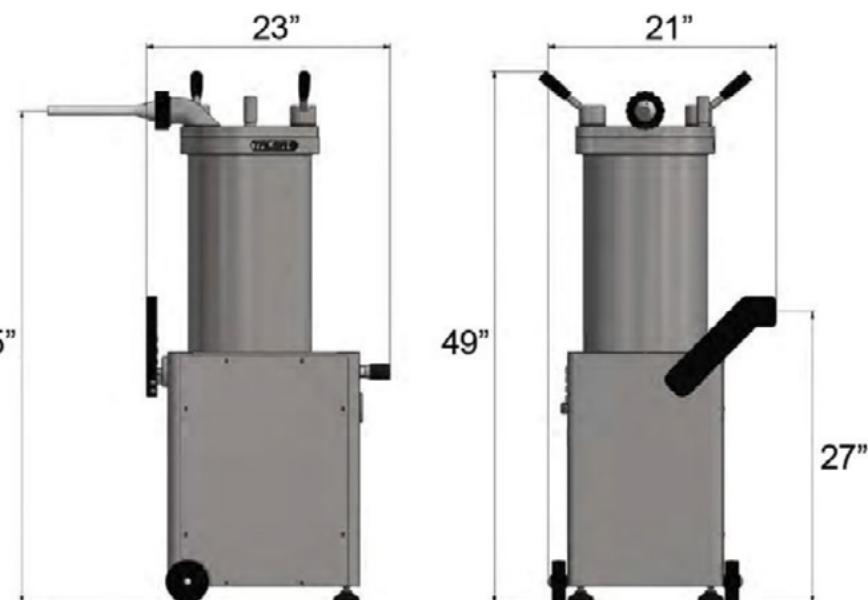

**65 lb Capacity**

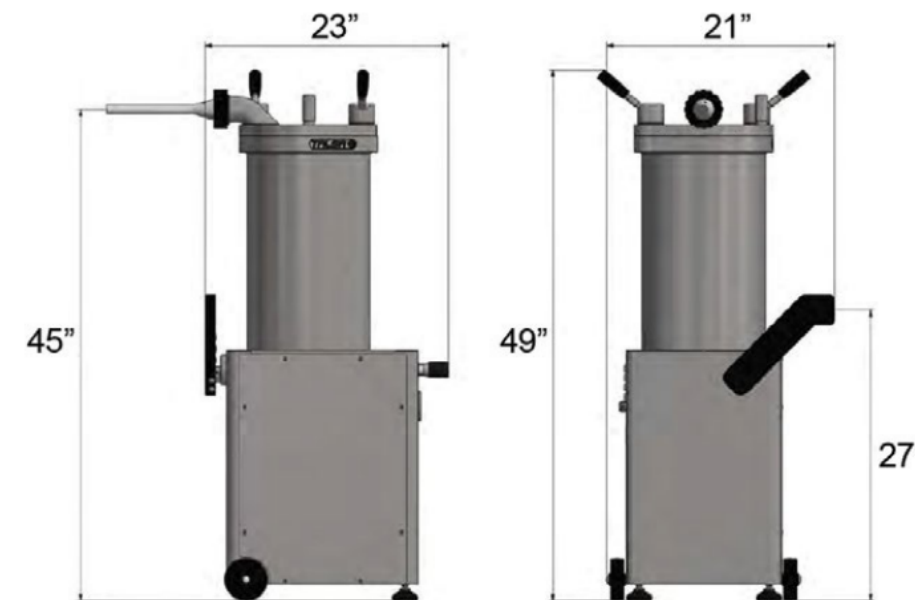

Item	45920	45959	45869
Model	SS-ES-0048-FS	SS-ES-0048-F	SS-ES-0048-FT
Approx. Meat Capacity	48 lb (22 kg)		
Barrel Capacity	26.6 qt (25.2 L)		
Operating Temperature	5° - 40° C (40° - 100° F)		
Power	1.75 hp / 1300 W		1.5 hp / 1100 W
Amps	18 A	8.8 A	5.6 A
Electrical	110V / 60Hz / 1Ph	220V / 60Hz / 1Ph	208V / 60Hz / 3Ph
Net Weight	310 lb (140 kg)		
Net Dimensions (WDH)	23" x 21" x 49"		

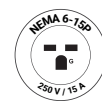
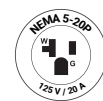

Item	45870	46101	46100
Model	SS-ES-0065-F	SS-ES-0065-FS	SS-ES-0065-FT
Approx. Meat Capacity	65 lb (29.5 kg)		
Barrel Capacity	37 qt (35 L)		
Operating Temperature	5° - 40° C (40° - 100° F)		
Power	1.75 hp / 1300 W		1.5 hp / 1100 W
Amps	18 A	8.8 A	5.6 A
Electrical	110V / 60Hz / 1Ph	220V / 60Hz / 1Ph	208-220V / 60Hz / 3Ph
Net Weight	350 lb (160 kg)		
Net Dimensions (WDH)	23" x 21" x 49"	23" x 21" x 49"	23" x 21" x 49"



# Hydraulic Sausage Stuffer Accessories

95 lb Capacity

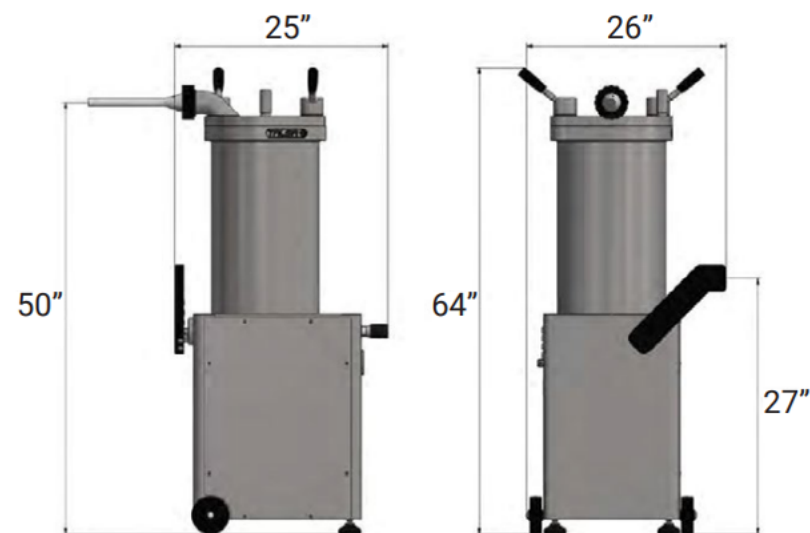

Item	45951	46102	46103
Model	SS-ES-0095-F	SS-ES-0095-FS	SS-ES-0095-FT
Approx. Meat Capacity	95 lb (43 kg)		
Barrel Capacity	53.9 qt (51 L)		
Operating Temperature	5 to 40°C (40 to 100°F)		
Power	2.5 hp / 1800 W		
Amps	23 A	12.5 A	8 A
Electrical	110V / 60Hz / 1Ph	220V / 60Hz / 1Ph	208-220V / 60Hz / 3Ph
Net Weight	580 lb (260 kg)		
Net Dimensions (WDH)	25" x 26" x 64"		



## All Stainless Steel Nozzle/Horn (Plastic Nozzle/Horn - 66843, 66844, 66845)

Item	External Dia.	Internal Dia.	Tube Length
66615	10 mm	8 mm	160 mm
66614	10 mm	8 mm	240 mm
16505	12 mm	10 mm	160 mm
36060	12 mm	10 mm	206 mm
36051	12 mm	10 mm	240 mm
66843	14 mm	10 mm	160 mm
36052	14 mm	12 mm	240 mm
19420	15 mm	12 mm	195 mm
16507	18 mm	15 mm	160 mm
36053	18 mm	15 mm	240 mm
16508	20 mm	17 mm	195 mm
66844	20 mm	16 mm	196 mm
36054	20 mm	17 mm	280 mm
16509	25 mm	22 mm	195 mm
36055	25 mm	27 mm	280 mm
66845	30 mm	26 mm	196 mm
36057	30 mm	27 mm	200 mm
16510	30 mm	27 mm	280 mm
36058	38 mm	35 mm	220 mm
16511	38 mm	35 mm	280 mm
36059	43 mm	40 mm	200 mm
16512	43 mm	40 mm	280 mm



## Hamburger Patty Former

Item	Compatible with
46955	F Series
46966	H Series



46966

## Other Accessories for Hydraulic Sausage Stuffer

Item	Description
46180	Portion Control Head for F Series
18944	Portion Control Head for H Series
69577	Swivel casters with brakes (Set of 2) - stainless steel, black. For item 45950, 46099, 46098, 45920, 45869, 45959, 45870, 46101, 46100
69578	Swivel casters with brakes (Set of 2) - stainless steel, black. For item 45951, 46102, 46103



46180/18944



69577 / 69578

## TERMS, CONDITIONS, WARRANTY AND POLICY

### Disclaimer

Although the information in our catalog is presented in good faith and believed to be correct at the time of printing, Trento makes no representations or warranties as to the completeness or accuracy of the information. Trento has no liability for any errors or omissions in the information contained in our catalog. Some variations between pictures in our catalog and product may occur.

Trento and the manufacturers represented herein, reserve the right to change, delete, or otherwise modify the information which is represented without any prior notice. Persons receiving this information will make their own determination as to its suitability for their own purposes prior to use. In no event will Trento be responsible for damages of any nature whatsoever resulting from the use of or reliance upon information from this catalog or the products to which the information refers.

All weights and measures shown are best approximations.

Possession of our price list or literatures does not constitute an offer to sell.

### Product Liability

Trento Equipment is not responsible for any harm or injury caused due to any person's improper or negligent use of this equipment. The product shall only be operated by someone over the age of 18, of sound mind, and not under the influence of any drugs or alcohol, who has been trained in the correct operation of this machine, and is wearing authorized, proper safety clothing.

Any modification to the machine voids any warranty, and may cause harm to individuals using the machine or in the vicinity of the machine while in operation.

### Prices and Product Specifications

Prices shown are list prices and are subject to trade discount and to change without notice. Prices may also be changed without notice due to unforeseen cost increases of imported products, raw materials, or currency fluctuations.

We carefully check pricing and product specifications, but occasionally errors can occur, therefore we reserve the right to change both without notice. We are not responsible for customer pricing errors to their end user. Some products listed may be non-stock items.

### Order Placement

All orders must meet or exceed a \$100.00 net minimum. A \$25.00 handling charge will automatically be added to any order if it does not meet the requirements set out above.

When placing verbal orders over the telephone, Trento is not responsible for verbal misunderstandings or mistakes. Please contact us immediately if you would like to cancel or modify

an order. If an order is already processing in our warehouse and being packed to ship, we cannot guarantee that the order can be canceled or modified. In order to maintain accuracy and efficiency in our order process, we are unable to alter any orders after they have been placed. If you would like to add to or modify your order in any way, please contact Customer Service to cancel the order so you can reorder exactly what you need.

Our warehouse works in the evening to package orders, ensuring shipments early the next day. If an order is packaged to ship in the evening the order is not able to be canceled. If we cannot cancel an order because it has already shipped from our warehouse, please see our returns procedures.

### Freight

Our freight program depends on the carrier and customs, the ETA given on transit days are an estimate. If there are unforeseen delays, then Trento is not responsible for lost sale or any other monetary compensation relating to the estimated delivery time.

All items shipped are subject to Declared Value. To decline the Declared Value on your shipment, it must clearly be indicated on your purchase order. By declining the Declared Value, the buyer must supply their carrier's account number as the order will be shipped 3rd party. The buyer assumes all responsibility for the shipment once it has left our warehouse. Shortage or damage in shipment does not excuse the buyer from timely and full payment of the invoice.

Unless we are advised otherwise, back orders will be shipped when the product arrives. If early shipment is requested, then freight charges become the customer's responsibility. On prepaid shipments, Trento retains the right to choose the carrier. Split shipments or back orders are not allowed on prepaid orders. Should the customer request a split or partial shipment, freight charges then become the customer's responsibility. Any accessorial freight charges are not included in prepaid shipping.

Our freight program depends on the carrier and customs, the ETA given on transit days are an estimate. If there are unforeseen delays, then Trento is not responsible for lost sale or any other monetary compensation relating to the estimated delivery time.

Certain Items are required to be shipped on a pallet due to weight, size, product type, and packaging constraints. Items of this nature are indicated in the Price List with a Delivery Truck Icon.

## TERMS, CONDITIONS, WARRANTY AND POLICY

Due to liability, dock-to-dock shipments do not include unloading or moving your item(s) from the back of our trucks. You are responsible for moving the item(s) from the back of our truck into your warehouse or building. If you have special delivery requirements, please contact us before finalizing your order. Any unexpected extra or surcharges (such as limited access, inside delivery, residential address, lift gate, etc.) identified by the freight company at time of delivery, will be added to the customer's Trento invoice.

### Freight Claims

Upon receipt of an Trento shipment, please inspect for external damage. If no damage is evident on the external packaging, open carton to ensure all ordered items are within the box, and that there is no concealed damage to the item(s).

If the package has suffered rough handling, bumps or damage (visible or concealed), please note it on the bill of lading before accepting the delivery and contact Trento within 24 hours, so we may initiate a claim with the carrier. A detailed report on the extent of the damage caused to the item(s) must be filled out within three days from the delivery date shown in the shipping documents.

Trento has no recourse for damaged products that were shipped collect or third party. In the event of a shortage, or if damage is detected on a collect or third party shipment, notify the delivering carrier at once to request an inspection and file a claim promptly. Any delay may cause you a loss. Shortage or damage in shipment does not excuse the buyer from a timely full payment of the invoice. We cannot

### Returns

Returns will not be accepted unless approved in writing. Minimum return amount of \$100.00 list. Returned goods must be received back to Trento within 30 days of purchase. To obtain a return authorization, please call 1-800-465-0234. All authorized returns must be shipped freight prepaid. A restocking charge of 35% will apply to unused products in their original packaging. Return of used products is subject to inspection and a restocking charge of 50% or more may apply. Special order, clearance, parts, demo items, vacuum pack bags, or nonstandard items are not returnable.

In order to improve our efficiency, Trento will call or email our customer advising the cost of the repair or requesting instructions on how to return the machine. After three attempts to contact our customer, the following terms will apply:

### Time frame

Days after contacting customer with quote for repair	Storage Fee
0-7 days	No charge
7-60 days	\$25
60 days	Dispose of machine / Trento property

Trento contacts customer with phone call and follow up with email, after repair or with quote.

reimburse claims for shortages or delays caused by the carrier responsible. By signing your name on the delivery receipt without noting any damages, you are stating that you have received your shipment in acceptable condition.

### Packaging

Trento reserves the right to package items in what it deems to be the most suitable, safe and economic manner. Packaging dimensions may not accurately represent final shipping dimensions.

### Taxes

Taxes are charged as required by local or federal law.

### Payment Terms

Full payment is due net 30-days for credit approved accounts. Accepted payment methods include cash, check, and wire transfer. Payment by Visa, MasterCard and American Express are accepted for prepayments or for net 10-day terms.

Trento will charge a 2.85% convenience fee on all credit card payments. As always customers will have the option to pay via Electronic Funds Transfer (EFT) or e-mail transfer; in Canada INTERAC E-TRANSFER and in the USA with ZELLE E-TRANSFER. Both methods will avoid convenience charges. Accounts without terms are subject to payment in advance, until credit approval has been granted and accepted. All products, are F.O.B. one of Trento's North American regional distribution centers. International orders are accepted against checks in advance and wire transfers only.

## TERMS, CONDITIONS & WARRANTY

### WARRANTY

Trento provides warranty against all defects of material and manufacturing, as well as for defective assembling, for all the products that we sell. The warranty periods vary based on our product categories.

Product Category	Warranty Period
Electrical and Gas equipment	1 year parts and labor (Standard)
Meat Slicers	1 Year Parts and Labor (Standard) 2 Year Parts and 1 Year Labor (Identified in catalog and website)
Refrigeration	1 Year Parts and Labor (Standard)
Smallwares/ Accessories	30 days
Non-Electrical Equipment	6 months
Extended Warranty	Investing in our warranty program means you'll receive peace of mind knowing your product is covered after the standard manufacturer's warranty expires. We'll make repairs on your covered product, including those made due to mechanical or electrical failure, at no cost to you. Your item will be serviced by an authorized Trento technician. For more information  For more information, call 1-833-487-3686 for a FREE QUOTE

Trento will provide our customers or end users with on-site warranty coverage on all equipment in excess of 115 pounds / 52 kilograms. For lighter products, Trento will provide carry in bench warranty. Bench warranty means that the product must be dropped off or delivered to us, or to one of our authorized service centers (at Trento's discretion), freight prepaid, for warranty evaluation. We will not accept COD or collect shipments.

## TERMS, CONDITIONS & WARRANTY

### Conditions of Trento Warranty:

1. A copy of the Bill of Sale and/or serial number is required for all warranty claims.
2. The on-site warranty applies to regular week day hours. Costs associated with holidays, weekends, evening or rush service calls will be the responsibility of either the end user or Trento dealer.
3. Remote geographic locations may limit guarantee to a parts only warranty. Labor, travel and mileage covered under warranty include straight time labor charges and travel charges within 100 miles / 160 km, round-trip. Overtime, premium labor charges and travel charges in excess of this round trip distance will not be covered by Trento and will be the responsibility of the person or firm requesting the service.
4. There is no on-site warranty for residential addresses (unless specified differently).
5. Warranty is valid only in country of purchase.
6. Trento reserves the right to either repair or replace a product at our discretion.
7. This warranty does not apply to abuse, willful or accidental damage, or to products used for other than their intended purpose.
8. Any tampering or modifications to any products automatically cancels the warranty guarantee. Items not covered by our guarantee include components which are subject to natural wear and tear. Products subject to abuse, misapplied, misused, subjected to harsh chemical action, or external causes such as electric power fluctuations or poor water quality, field modified (without the approval of Trento), improperly installed or maintained, damaged by flood, fire or other acts of God, or which have altered or missing serial numbers automatically void warranty.
9. This warranty is not transferable and is limited to original installation of equipment sold by Trento for the original user.
10. This warranty does not apply to any equipment that has not been installed in accordance with the directions published in the appropriate installation and operation manuals.
11. If the equipment have been changed, altered, modified or repaired with parts not authorized by Trento or by a non-qualified Service Technician, then Trento shall not be responsible for warranty claim.

12. Adjustments such as calibrations, leveling, tightening of fasteners or utility connections normally associated with original installation are the responsibility of installer and not that of Trento. Regular maintenance, such as cleaning, greasing, de-scaling, tightening, sharpening, or anode parts shall be the responsibility of the customer.
13. If required by Trento, customer shall return to Trento for examination of any failed product or part to confirm that the part has failed as a result of material or workmanship.
14. All parts orders are shipped via ground courier only. Extra rush shipment charges will be the responsibility of the end user or dealer.
15. Dealers and end users should not replace or authorize repair of Trento equipment without an approved return authorization number. Cost incurred in such repairs will be at the dealers or end user's expense.
16. For an end user on-site service call, Trento will require a credit card pre authorization, until the technician determines it is a warranty repair.

This warranty and the liabilities set forth herein are exclusive and in lieu of all of their liabilities and warranties, express or implied, including but not limited to, implied warranties of merchantability and fitness for particular warrantee purpose and constitutes the only warranty of Trento. Trento's liability on any claim, including but not limited to negligence, shall not exceed the price of the equipment that gives rise to the claim.

The foregoing warranty is the entire warranty of Trento. Trento neither assumes nor authorizes any other person, purporting to act on its behalf, to modify or to change this warranty, or any other warranty or liability concerning Trento equipment.

This warranty provides the exclusive remedy against Trento relating to all Trento products, whether in contract or in tort or under any other legal theory, and whether arising out of warranties, representations, instructions, installations or defects from any cause.

Trento shall not be liable, under any legal theory, for loss of use, revenue or profit, or for substitute use or performance, or for incidental, indirect, or special or consequential damages or for any other loss of cost of similar type. The liability of Trento is limited to the repair or replacement of any part found to be defective.

## TERMS, CONDITIONS & WARRANTY

### Conditions of Trento Warranty:

#### WHAT IS PROPOSITION 65? (ATTENTION: CALIFORNIA RESIDENTS)

Proposition 65 requires businesses to provide warnings to Californians about significant exposures to chemicals that cause cancer, birth defects or other reproductive harm. These chemicals can be in the products that Californians purchase, in their homes or workplaces, or that are released into the environment. By requiring that this information be provided, Proposition 65 enables Californians to make informed decisions about their exposures to these chemicals.

Proposition 65 also prohibits California businesses from knowingly discharging significant amounts of listed chemicals into sources of drinking water.

Proposition 65 requires California to publish a list of chemicals known to cause cancer, birth defects or other

reproductive harm. This list, which must be updated at least once a year, has grown to include approximately 900 chemicals since it was first published in 1987.

Proposition 65 became law in November 1986, when California voters approved it by a 63-37 percent margin. The official name of Proposition 65 is the Safe Drinking Water and Toxic Enforcement Act of 1986.

Trento has chosen to provide a warning based on its knowledge about the presence of one or more listed chemicals without attempting to evaluate the level of exposure. Products on the Trento website may be below the Proposition 65 exposure levels of concern or could even be zero. However, due to the size and range of our products and out of an abundance of caution, Trento has elected to place the Proposition 65 warning notification on all its products.

#### MINIMUM ADVERTISED PRICE (MAP) POLICY

USA Policy Effective Date: July 31, 2020

Canada Policy Effective Date: September 21, 2020

##### SUMMARY

Trento has established a Minimum Advertised Price (MAP) Policy that applies to all authorized distributors and dealers (Resellers selling products in or into the United States and or Canada). The purpose of the Policy is to assure that end user purchasers have continuing access through our authorized Resellers to accurate and expert information, specifications, and support needed to identify, evaluate and purchase the products which are optimum for their requirements. The MAP Policy applies to prices that may be advertised by Resellers and does not restrict the sales price of products. The MAP Policy includes specific guidelines for administration of the program and penalties for violations.

##### Purpose of MAP Policy

The Trento MAP Policy provides an enhanced equipment purchasing experience by supporting Resellers who invest in knowledge of products and their functional performance capabilities, customer service and supports, and cooperate with Trento in maintaining the premium brand image and long-term competitiveness of the Trento brand. Due to the nature and uses of our products, it is necessary for authorized Resellers and their sales associates to commit significant time and resources to learning, supporting, specifying, and selling our products. In addition, we recognize there are significant investments required in properly supporting, marketing and advertising our products, and

educating the equipment purchaser about each product's unique application, benefits and value proposition. We sell our products to authorized Resellers at a cost/price structure intended to provide the Reseller with margins adequate to fund these activities. Therefore, it is the purpose of this MAP Policy to support our mutually beneficial cost/price structure for all authorized Resellers.

##### MAP Definition and Application

This Policy applies to select brands and products within the Trento portfolio. Trento publishes and maintains for its Reseller partners a comprehensive list of the products and MAP for each.

Resellers may advertise prices equal to or greater than the MAP for covered products sold as "new." Trento defines "new" products as, 1) those sold by Trento or one of its authorized Resellers without prior in-service use by any end user purchaser, or 2) any product sold by a Reseller when covered by the manufacturer's original warranty.

The MAP Policy does not apply to specific pieces of equipment when all the following conditions are met:

1. The advertisement uses one of the following terms to clearly indicate the condition of the unit: "used", "damaged" or "floor model".
2. The advertisement included the following terms used in all capital letters "NO FACTORY WARRANTY".

## TERMS, CONDITIONS & WARRANTY

3. The advertisement included the serial number of the unit that is being offered.

4. The Reseller has previously notified Trento that the factory warranty should be removed from this unit. (This can be done with an email to the MAP Administrator for Trento.) This MAP Policy prescribes the lowest price that an authorized Reseller may advertise in any form of advertising, including, but not limited to internet (including "add to cart" and "checkout" pages), print, direct mailing, radio, group or "broadcast" email, group or "broadcast" FAX and all other forms of pricing advertisement.

Trento defines advertising as promulgation, publication or other promotion of product and pricing information outside the Reseller's physical business location and intended for more than a single individual.

Any direct request for pricing made by an individual prospective purchaser to a Reseller in person or through other deliberate action is considered by Trento to be a request for a price quotation from the prospective purchaser to the Reseller, thus MAP does not apply.

By definition, resellers may not make any statements, displays or communications that indicate, state, imply, or suggest that a lower price may be found at the online check out, including but not limited to: "click here for lower price," "see lower price in cart," "add to cart for lower price," "check cart for lower price," "chat for price," "mouse over for price," "text for price," "log-in for price," "e-mail for a better price," "call for lower price," or similar language.

Such website features as automated "bounce-back" pricing emails, pre-formatted e-mail responses, forms, automatic price display, and other similar features are considered communications initiated by the Reseller (instead of the customer) and constitute "advertising" under this MAP Policy.

This MAP Policy also applies to any activity which Trento determines is designed or intended to circumvent the intent of this MAP Policy.

The advertising or offer of new Oman products in any auction is prohibited and is a violation of our MAP Policy, except for auctions which include a published minimum purchase price or "reserve price" which complies with the Trento MAP Policy.

If one or more products from Trento are "bundled" or combined in an advertisement, the aggregate price for all Trento products offered for sale in the bundle may not be lower than the cumulative MAP for each of the products when sold separately.

Under the MAP Policy, Trento prohibits the use of split-screen, side-by-side advertising, or pop-ups to advertise a similar product of any other brand. Trento prohibits any Reseller from directing (automatically, inadvertently or otherwise) an Trento customer who is in search of an Trento product or item to any other brand.

The MAP Policy is not applicable to in-store advertising that is displayed only in a physical store location. In-store displays, point-of-sale signs, hangtags, bar-codes, QR codes or similar marks on products or product packaging which present the price are not considered "advertising" for purposes of this MAP Policy.

This Policy does not affect or restrict the price at which an authorized Reseller sells our products. Our authorized Resellers are free to sell Trento products at whatever price they may choose.

##### MAP Disclosure or Undercutting Prohibited

The working "minimum advertised price," "MAP Price," and/or "MAP" or similar references to the MAP Policy shall not appear in any advertisement, quotation, or communication which includes Trento products. Such reference is a violation of the Trento MAP Policy.

Advertising that indicates that the MAP Price is not the applicable price for the product or that a lower price is available also are violations of the MAP Policy. Therefore, advertisements shall not display any prices that have a strike through or refer to the MAP price as "list price," "factory price," "manufacture's price" or similar statements.

Advertisers shall not use "cookies" or other means to recognize a repeat visitor which trigger display of prices that are lower than MAP without a full log in process where an active session was discontinued.

##### Promotional Pricing and Discontinued Products

From time to time, Trento may conduct promotions for products covered by the MAP Policy. In such events, Trento reserves the right to modify or suspend the MAP with respect to the promotional products by notifying authorized Resellers of such promotions.

Trento further reserves the right to adjust the MAP with respect to all or certain products in its sole discretion upon written notice to authorized Resellers. Upon Trento's prior written notification, authorized Resellers may advertise such products consistent with the written notification. Trento may also suspend or eliminate MAP pricing on discontinued products in its discretion, upon notice to its authorized Resellers.

**MAP Enforcement**

Trento will monitor compliance with this Policy. The enforcement process is based on violations across all Trento brands and products covered by this MAP Policy. Our enforcement process allows immediate correction of errors, with subsequent penalties for delays or repeated violations within 60 days of such violation. The consequences are targeted at the violator and are not intended to penalize the equipment purchaser.

In the event a violation is determined, the following actions may be taken:

1. First Violation: The Reseller will be contacted in writing and allowed 24 hours to comply with the Policy. If correction is made, the violation is recorded, but no penalties will apply. If the violation is not corrected within 24 hours, then the Reseller will be notified in writing and a second violation will be recorded.

2. Second Violation: The Reseller will be contacted in writing and allowed 24 hours to comply with the Policy. If correction is made, the violation is recorded, but no penalties will apply. If the violation is not corrected within 24 hours, then the Reseller will be notified in writing and a third violation will be recorded.

3. Third Violation: The Reseller will be notified by email and all shipments of all products from all Trento warehouses will be suspended until all violations are resolved. Additionally, all rebates may be held for the same calendar quarter in which the violation occurred until all violations are resolved.

4. Fourth Violation: The Reseller will be notified by email and all shipments of all products from all Trento warehouses will be suspended until such violations are resolved. Additionally, any rebates the Reseller may have earned for any and all calendar quarters in which any MAP violation occurred will be forfeited and subsequent violations will result in additional rebates forfeited and termination of the Reseller.

**DEALER ACCOUNTABILITY**

In the case of a MAP violation by a Reseller who does not have an authorized relationship with Trento and instead purchases Trento products from an authorized distributor or any other Reseller (i.e., dealer-to-dealer sale), Trento will pursue enforcement actions against the authorized distributor or Reseller as provided above in this Policy.

**OTHER PROVISIONS**

This program is managed by the MAP Policy Administrator for Trento. Trento reserves the right to change, add or delete covered products, and change or cancel the MAP Policy at any time upon written notice to authorized Resellers and distributors.

Only the MAP Policy Administrator may provide advice to Resellers concerning compliance with the MAP Policy or authorize exceptions to the MAP Policy. No other individual, including any employee or representative of Trento, may provide such advice or authorizations regarding this Policy to any Reseller. It is the Reseller's sole responsibility to remain aware of any changes to the Trento MAP Policy. The MAP Policy and our MAP price list are available to authorized Resellers directly from Trento by contacting MAPadmin@Trento.com.

**MAP Policy Administrator**

MAPadmin@Trento.com  
Trento Inc.

# TRENTO

ELEVATING CULINARY EXCELLENCE

# INDEX

## Index By Item #

AH531 190	10221 166	13253 118	13345 117	13434 117	19434 117	31344 224	40642 74
10074 180	10222 166	13255 118	13346 117	13436 117	19435 117	31438 227	40643 74
10075 180	10223 166	13256 118	13347 117	13437 117	19436 118	31806 118	40644 74
10076 180	10224 166	13258 118	13349 117	13439 117	19437 118	36051 254	40645 74, 75
10081 180	10225 166	13259 118	13353 117	13440 112	19674 183	36052 254	40954 173
10082 180	10226 166	13260 118	13354 117	13606 217	19737 118	36053 254	40955 173
10084 180	10227 166	13263 118	13355 117	13607 217	19756 117	36054 254	40956 173
10086 180	10228 166	13265 118	13356 117	13616 218	19757 117	36055 254	41187 142
10089 180	10229 166	13266 118	13357 117	13620 220	19921 175	36057 254	41262 146
10090 180	10230 166	13284 118	13358 117	13621 221	20013 239	36058 254	41264 149
10093 180	10231 166	13285 118	13359 117	13623 219	20014 240	36059 254	41422 75
10094 180	10232 166	13286 113	13361 117	13625 222	20054 117	36060 254	41474 145
10095 180	10233 166	13288 118	13363 117	13628 224	20079 117	36517 117	41483 165
10103 208, 210	10234 166	13289 118	13369 117	13629 225	20169 194	37451 214	41513 165
10117 180	10235 166	13290 118	13371 117	13634 239	20170 194	38915 232	41600 75
10118 180	10830 181	13291 118	13372 117	13635 225	20209 118	38917 227	41603 74
10119 180	10927 179	13292 118	13373 117	13637 225	20387 238	39321 117	41604 74
10120 180	11051 208	13294 118	13375 117	13639 239	20445 118	39477 229	41605 74
10121 180	11053 209	13295 118	13376 117	13641 226	21180 166	39494 33	41607 75
10122 180	11375 78	13296 118	13378 117	13642 226	21187 117	39498 175	41698 185
10123 180	11376 78	13297 118	13381 117	13643 226	21188 117	39517 41	41699 186
10181 166	11377 78	13298 118	13382 117	13645 229	21258 117	39518 41	42939 117
10182 166	11378 78	13299 118	13384 117	13654 228	21623 152	39519 42	44006 231
10183 166	11380 78	13300 118	13387 117	16448 180	21624 223	39520 42	44007 235
10184 166	11403 174	13301 118	13391 117	16505 254	21631 117	39583 230	44019 194
10185 166	11404 172	13302 118	13392 117	16507 254	21719 172	39584 230	44023 21
10186 166	11405 174	13303 118	13393 117	16508 254	22129 117	39591 117	44025 32
10187 166	11411 169	13304 118	13395 117	16509 254	22323 180	39631 231	44116 192
10188 166	11426 86	13305 118	13397 111	16510 254	22324 180	39674 185	44184 189
10189 166	11428 86	13306 118	13399 117	16511 254	22325 180	39675 185	44185 189
10190 166	13160 93	13307 118	13402 117	16512 254	22326 180	39684 33	44256 90
10191 166	13162 93	13308 118	13403 117	16643 111	22327 180	39685 32	44269 95
10192 166	13163 93	13309 118	13404 117	16988 105	22328 180	39686 32	44375 237
10193 166	13166 93	13310 118	13405 117	16989 105	22333 180	39687 29	44431 85
10194 166	13167 94	13311 118	13406 117	16990 105	23340 117	39688 30	44476 85
10196 166	13170 94	13312 118	13407 117	16991 105	23642 117	39689 22	44634 16
10197 166	13171 94	13313 118	13408 117	17127 117	23719 118	39690 117	44636 19
10198 166	13172 94	13314 118	13409 117	17129 117	23766 117	39703 18	44637 20
10200 166	13173 94	13315 118	13410 117	17132 118	23825 117	39714 210	44764 107
10203 166	13174 94	13320 107	13411 117	17137 21	23827 117	39884 174	44954 145
10204 166	13177 98	13321 117	13412 117	17876 166	23865 170	40298 145	44989 147
10205 166	13231 106	13322 117	13414 117	18637 93	24013 117	40299 142	45143 142
10206 166	13234 105	13326 117	13415 117	18660 166	24014 117	40345 142	45176 142
10207 166	13236 111	13329 117	13416 117	18676 166	24086 118	40399 107	45199 75
10210 166	13238 118	13333 117	13417 117	18677 166	24092 117	40462 108, 109, 110	45232 146
10211 166	13241 118	13334 117	13419 117	18830 239	24204 180	40531 46	45304 240
10212 166	13244 118	13335 117	13420 117	18901 193	24212 118	40539 47	45339 117
10213 166	13247 118	13336 117	13422 117	18902 193	24214 118	40619 173	45344 142
10218 166	13248 118	13339 117	13426 117	18903 193	24490 118	40633 76	45356 101
10219 166	13250 118	13341 117	13429 117	18917 117	26072 238	40634 76	45376 147
10220 166	13251 118	13343 117	13431 117	18944 254	26073 238	40635 75	45388 117
				18945 117	26074 238	40636 75	45403 176
				18986 240	26084 117	40637 73	45404 176
				18987 240	27208 117	40638 73	45412 178
				19125 166	31332 117	40639 97	45417 92
				19305 117	31342 218	40640 97	45418 92
				19420 254	31343 220	40641 74	45485 146

45487	146	46387	117	47711	202	48143	58	49002	125	49532	232
45506	200	46531	186	47712	188	48144	58	49003	125	50000	163
45507	200	46612	117	47713	188	48145	61	49004	126	50001	164
45516	122	46673	196	47715	246	48147	149	49005	126	50002	165
45517	121	46701	185	47716	248	48160	246	49011	103	50003	162
45518	121	46702	185	47718	153	48161	246	49060	53	50005	162
45519	122	46724	76	47741	185	48162	246	49063	54	58178	25
45520	122	46725	70	47755	184	48163	246	49064	54	58179	28
45532	118	47000	150	47772	186	48164	246	49065	54	59006	157
45559	200	47001	150	47776	202	48165	246	49066	54	59007	157
45636	47	47002	150	47792	186	48166	246	49067	54	59008	159
45637	89	47003	150	47793	186	48167	248	49068	53	59009	159
45790	47	47004	150	47822	188	48168	248	49069	53, 54	59013	159
45869	251	47005	150	47823	188	48169	248	49070	53, 54	59014	160
45870	252	47007	150	47834	206	48170	248	49071	54	59020	162
45915	118	47008	150	47835	206	48203	59	49072	54	59134	163
45920	251	47009	150	47836	206	48204	59	49073	54	59135	164
45923	36	47010	150	47851	185	48205	59	49074	54	59136	160
45950	250	47011	150	47852	186	48206	59	49075	54	59321	66
45951	253	47055	190	47853	186	48207	59	49076	54	59322	66
45959	251	47074	166	47854	185	48208	59	49080	10	59323	69
45983	240	47083	181	47855	185	48226	107	49081	9	59324	69
46080	192	47084	22	47856	207	48246	154	49082	9	59325	69
46088	236	47087	91	47857	207	48271	59	49083	9	59326	69
46089	237	47088	91	47917	166	48278	59	49085	11	59327	69
46098	250	47111	216	47930	176	48279	59	49086	11	59328	67
46099	250	47113	216	47931	176	48280	59	49087	12	59329	69
46100	252	47117	133	47960	43	48309	248	49088	12	59330	66
46101	252	47261	181	47982	72	48391	227	49089	12	59331	67
46102	253	47269	181	47985	72	48399	69	49090	12	59332	69
46103	253	47287	91	47989	44	48400	69	49097	84	59333	69
46134	240	47288	91	47990	46	48402	69	49098	84	59334	69
46162	230	47289	166	48009	43	48445	149	49099	82	59335	69
46163	230	47404	114	48036	133	48446	149	49100	82	59336	69
46170	113	47405	114	48037	135	48460	69	49106	84	59337	69
46171	113	47406	114	48038	135	48461	69	49107	84	64678	189
46180	254	47407	114	48039	135	48462	69	49108	84	66047	149
46183	145	47408	114	48040	136	48463	69	49117	108	66614	254
46184	142	47409	114	48041	136	48465	69	49118	110	66615	254
46204	209	47410	114	48042	136	48466	69	49119	108, 110	66843	254
46215	204	47417	92	48043	137	48467	69	49120	108, 110	66844	254
46216	204	47418	92	48044	137	48468	69	49122	96	66845	254
46268	32	47469	166	48045	137	48470	69	49123	96	69577	254
46292	106	47489	85	48046	139	48482	99	49125	2	69578	254
46296	114	47490	85	48047	139	48513	160	49126	2		
46297	114	47531	150	48048	139	48580	100	49127	4		
46298	114	47532	150	48055	214	48581	100	49128	4		
46300	106	47533	150	48056	214	48583	99	49129	53		
46301	106	47580	100	48057	214	48603	79	49130	53		
46302	106	47581	100	48058	214	48700	186	49131	54		
46303	106	47582	99	48109	171	48702	196	49132	53		
46304	106	47583	99	48110	32	48703	196	49145	53		
46305	106	47702	70	48111	29	48704	196	49146	53		
46306	106	47706	236	48126	60	48763	103	49160	53		
46336	240	47707	236	48127	60	48764	103	49161	53		
46337	240	47709	207	48137	58	48765	103	49162	53		
46386	117	47710	207	48142	58	49001	124				

## Index By Category

### B

#### Blenders

- Drink Blenders
  - Santos #54 **16**
  - Santos #62 Heavy Duty **18**
- Immersion Blender **188**

### C

#### Cheese

- Cutting Machine **177**
- Drying **121**
- Graters
  - Heavy Duty **175**
  - Light & Medium Duty **171-174**
  - Super Heavy Duty **176**

#### Coffee

- Santos #55 Silent Espresso Grinder **20**
- Santos #63 High Output Grinder **19**

### D

#### Dishwashers

- Kromo Aqua 50 USA **2**
- Kromo Dupla 50 USA **2**
- Kromo Hood 110 USA **4**
- Kromo Hood 130 Premium USA **4**

#### Dough

##### Mixers

- Fork
  - Santos #18 **89**
  - Single Speed 26 Qt Mixer **90**

##### Spiral

- Fixed Bowl **92**
- Heavy Duty **93-96**
- Removable Bowl **91**

##### Press **101**

##### Rollers

- Adjustable Roller with 13.3" max width **97**
- Adjustable Roller with 15.75" max width **98**

##### Rounders & Dividers **99**

##### Sheeters **103**

#### Drink Dispensers

- Ugolini Arctic Compact **11**
- Ugolini Arctic Deluxe **12**

### F

#### Fish

##### Curing

- 132 lb **124**
- 220 lb **125**
- 330 lb **125**
- 440 lb **126**
- 440 lb (220+220) **126**

#### Food Processing

- Blast Chillers **196**
- Bread Graters **169-170**
- Bowl Processors **181-182**
- Dry Grinders **192**
- Pacojet **184**
- Pacojet Accessories **183**
- Potato Peelers **189-190**
- Processor & Discs **179**
- Tomato Squeezers **193**

### G

#### Gelato Maker

- Musso Mini **25**
- Musso Stella **28**

#### Granita Machine

- Giant **10**
- Ugolini MT **9**

### I

#### Ice

##### Ice Crusher

- 3L Ice Crusher **22**
- Santos #53 **22**

##### Ice Shaver

- 2L Ice Shaver **21**
- Santos #09 **21**

#### Ice cream Maker

- Musso Mini **25**
- Musso Stella **28**

### J

#### Juicers

##### Citrus

- Santos #10 **29**
- Santos #11 **32**
- Santos #38 **30**
- Santos #52 **32**
- Santos #70 **32**

##### Fruit and Vegetable

- Santos #50 **33**
- Santos #65 **36**
- Santos #68 **33**

##### Zumoval

- Big Basic **43**
- FastTop **46**
- Minimatic **42**
- Minimax **41**
- Options and Accessories **47**
- Top **44**

### K

#### Kebab Broilers

- Potis Accessories **54**
- Potis Electric **54**
- Potis Natural Gas **53**

### M

#### Meat

##### Aging

- 176 lb **2.0 133**
- 264 lb **2.0 133**
- 330 lb **3.0 135**
- 496 lb **3.0 136**
- 992 lb **3.0 137**
- 992 lb **3.0 Twin 137**
- 132-330 lb **4.0 142**
- 440-882 lb **4.0 142**

##### Stagionello Comparison Chart **131**

##### Combination Curing **147**

##### Processing

##### Bandsaws **200**

##### Bowl Cutters

- Heavy Duty **203-204**
- Medium Duty **201-202**
- Super Heavy Duty **205-206**

##### Grinder

- # 12 **208**
- # 22 **209**
- # 22 Heavy Duty **209**
- # 32 Heavy Duty **210**

##### Mixer **211-214**

##### Sausage Stuffers

- Accessories **254**
- Electric **245**
- Heavy Duty Hydraulic **249-253**
- Manual Horizontal **245-246**
- Manual Vertical **247-248**

##### Tenderizer **207**

##### Slicer-Commercial

- Automatic Gravity Feed **228-229**
- Gear Driven Gravity Feed **226-227**
- Gravity Feed Belt Driven **217-225**
- Selection Guide **243**
- Vertical Feed Horizontal Carriage **230-232**

##### Slicer-Residential

- Berkel Home 250 **216**

##### Slicers-Volano **235-239**

- Accessories **240**
- Flywheel Selection **241**

##### Salami **145-146**

##### Stagionello Accessories **149**

##### Stagionello Salts & Spices **150, 211**

### O

#### Oven

- Deck Oven

Compact **76**

Entry Max **75**

Fuoco **73**

#### Dome Oven

- Accessories **69**
- Alfa Forni Quick **65**
- Alfa Forni Zeno **68**
- Valoriani Baby **57**
- Valoriani Igloo **59**
- Valoriani Rotativo **61**

#### Tunnel Oven

- Stackable 63" with 20" belt **71**

### P

#### Panini Grill

- Double **78**
- Single **78, 79**

#### Pasta

##### Cookers

- Baskets **84**
- Double Tank **81**
- Single Tank **84**

##### Die Guide **116-118**

##### Extruders

- Countertop **107-108**
- Floor Model Heavy Duty **109-113**

##### Ravioli Machine **114**

##### Sheeters

- Commercial **106**
- Residential **105**

#### Patty Making

- Paper **85**
- Top Down Press **86**

### S

#### Slushy Machine

- Ugolini Giant **10**
- Ugolini MT **9**

### V

#### Vacuum Packing

- Automatic Heavy Duty **153**
- Light Duty **152**
- TurboVac
  - Double Chamber Sealers **163-165**
  - Mobile Sealers **161**
  - Tabletop **157-160**
- Vacuum Sealer Bags **166**
- Vertical Heavy Duty **154**

Notes

**TRENTO**

---

ELEVATING CULINARY EXCELLENCE

---



### Head Office and Canadian Distribution Center

3115 Pepper Mill Court,  
Mississauga, Ontario,  
L5L 4X5, Canada

### Western USA Office and Distribution Center

12854 E. Florence Avenue,  
Santa Fe Springs, California,  
90670, USA

### Eastern USA Distribution Center

4450 Witmer Industrial Estates,  
Unit 4, Niagara Falls, New York,  
14305, USA

# TRENTO



[sales@trentoequipment.com](mailto:sales@trentoequipment.com)



[www.trentoequipment.com](http://www.trentoequipment.com)

1-833-487-3686